



DS5C1 series servo driver

User manual

WUXI XINJE ELECTRIC CO., LTD.

Data No. SC5 11 20240321EN 1.3.1

Basic explanation

- Thank you for purchasing XJNIE DS5C1 series servo driver products.
- This manual mainly introduces the product information of DS5C1 series servo driver and MS5/6 series servo motor.
- Before using the product, please read this manual carefully and connect the wires on the premise of fully understanding the contents of the manual.
- Please deliver this manual to the end user.

This manual is suitable for the following users

- Designer of servo system
- Installation and wiring workers
- Commissioning and servo debugging workers
- Maintenance and inspection workers

Get the manual

- Please consult the supplier, agent and office who purchased the product.

Declaration of liability

- Although the contents of the manual have been carefully checked, errors are inevitable, and we cannot guarantee complete consistency.
- We will often check the contents of the manual and make corrections in the subsequent versions. We welcome your valuable comments.
- If there is any change to the contents introduced in the manual, please understand without further notice.

Contact information

- Tel: 400-885-0136
- Fax: 0510-85111290
- Address: No.816, Jianzhu West Road, Binhu District, Wuxi City, Jiangsu Province, China
- Postcode: 214072

WUXI XINJE ELECTRIC CO., LTD. Copyright

Without explicit written permission, this material and its contents shall not be copied, transmitted or used, and the violator shall be liable for the losses caused. All rights provided in the patent license and registration including utility module or design are reserved.

Oct 10,2021

Safety Precautions

Before using this product, please read this part carefully and operate after fully understanding the use, safety and precautions of the product. Please connect the product correctly on the premise of paying great attention to safety.

The problems that may arise during the use of the product are basically listed in the safety precautions, and all are indicated by the two levels of attention and danger. For other unmentioned matters, please follow the basic electrical operation rules.



Caution

When used incorrectly, there may be danger, moderate injury or minor injury, and property loss.



Danger

When used incorrectly, it may cause danger, personal casualties or serious injuries as well as serious property losses.



Attention to product confirmation

1. Do not install damaged drives, drives that lack spare parts, or drives whose models do not meet the requirements.



Transportation and storage

1. Do not place or store in a place where the ambient temperature exceeds the storage temperature, the relative humidity exceeds the storage humidity, the temperature difference is large, and the condensation occurs.
2. Do not contact corrosive and combustible gases or places with much dust.
3. Do not place in a place with large vibration or impact that is directly transmitted to the servo driver.
4. It is strictly forbidden to hold the motor cable when handling.



Installation notes

1. It is strictly forbidden to place near flammable gas, otherwise it will cause fire.
2. Be sure to follow the installation direction requirements to prevent drive failure.
3. It is forbidden to expose the product to water, corrosive gases, flammable gases and other substances, causing electric shock and fire hazards.
4. Before installing wiring, be sure to disconnect the power supply to prevent electric shock.
5. Do not touch the conductive part of the product directly, which may cause misoperation and malfunction.



Cautions for wiring

1. Please connect AC power to L/N, L1/L2/L3 or R/S/T on the dedicated power terminal of the driver. Do not connect the output terminals U, V, W of the driver to the three-phase power supply.
2. Please connect the ground wire correctly. Poor grounding may cause electric shock. Please use 2 mm² wire to ground the ground terminal of the driver.
3. Please lock the fixed screw of the terminal, otherwise it may cause fire.
4. Be sure to disconnect all external power supply before wiring the driver.
5. Wiring, please ensure that the encode cable, power cable is loose, do not tighten, lest cable damage.



Operation Cautions

1. Do not touch the rotating part of the motor after the driver is running. There is a danger of injury.
2. During the test run, please carry out the test run of the motor under the idle shaft state in order to prevent the accidents, otherwise it may cause injury.
3. Please set appropriate parameters before operation, otherwise it may cause the machine out of control or failure.
4. Please do not touch the radiator during operation. There is a risk of scalding.
5. Do not change the wiring when the power is on. There is a risk of injury.
6. Do not switch power frequently. If you need to switch power many times, please control it once in 2 minutes, otherwise the charging resistance of the driver may be damaged. Due to frequent switching, the relay is energized before it is released, which may cause tripping.



Maintenance and inspection

1. Turn on and off the power supply by professionals.
2. It is strictly forbidden to use gasoline, acid, diluent and alkaline detergent to avoid shell damage or discoloration.
3. If the driver is replaced, please transfer the parameters of the original driver to the new driver before restarting the operation, otherwise mechanical damage or even personal injury will be caused.
4. It is strictly prohibited to change the wiring when the power is on, otherwise it will cause electric shock or injury.
5. It is strictly forbidden to remove the servo motor during operation, otherwise electric shock or injury may be caused.
6. It is strictly forbidden to touch the inside of servo driver and servo motor during operation, otherwise electric shock or injury may be caused.
7. Do not touch the terminal within 10 minutes after the power is turned off, otherwise the residual voltage may cause electric shock or injury.



Wiring attention

1. Do not cross the power line and the control signal line from the same pipeline, nor tie them together. The power line and the control signal line are separated by more than 30 centimeters.
2. For signal wire and encoder (PG) feedback wire, please use multi stranded wire and multi-core stranded overall shielded wire.
3. The longest signal input line is 3m, and the longest PG feedback line is 30m.
4. Please conduct wiring correctly and reliably, otherwise the motor will be out of control or failure, and serious injury will be caused.
5. It is strictly forbidden to use it when the power supply is in poor condition or exceeds the specified voltage variation range, otherwise it will cause mechanical damage.
6. Please take appropriate shielding measures when there is static electricity, strong electromagnetic field, radiation, and nearby power lines.

Catalog

►► CONFIRMATION ON PRODUCT ARRIVAL	5
1 SELECTION OF SERVO SYSTEM	6
1.1 SELECTION OF SERVO DRIVER	6
1.1.1 Model name	6
1.1.2 Description of each part	6
1.1.3 Performance specification	7
1.2 SERVO MOTOR SELECTION	7
1.2.1 Model name	7
1.2.2 Description of each part	8
1.2.3 Axial force and radial force	9
1.3 CABLE SELECTION	9
1.3.1 Encoder cable	9
1.3.2 Power cable	10
1.3.3 EtherCAT communication cable	10
1.3.4 Description of each part	11
1.4 SELECTION OF OTHER ACCESSORIES	15
2 INSTALLATION OF SERVO SYSTEM	16
2.1 SERVO DRIVER INSTALLATION	16
2.1.1 Installation site	16
2.1.2 Environment condition	16
2.1.3 Installation standard	16
2.2 SERVO MOTOR INSTALLATION	18
2.2.1 Environment condition	18
2.2.2 Installation cautions	19
2.2.3 Installation environment	19
2.3 SERVO CABLE INSTALLATION	20
2.3.1 Cable selection	20
2.3.2 Xinje cable specification	21
2.4 SERVO DRIVER DIMENSION	23
2.5 SERVO MOTOR DIMENSION	26
3 SERVO SYSTEM WIRING	36
3.1 SERVO DRIVER TERMINAL WIRE SPECIFICATION	36
3.2 MAIN CIRCUIT TERMINAL	37
3.3 INTERFACE TERMINAL	39
3.3.1 CN0, CN1, CN2, CN3 terminal description	39
3.3.2 CN0 control terminal	39
3.3.3 CN1 communication terminal description	40
3.3.4 CN2 encoder interface description	40
3.3.5 CN3 terminal (RS232)	40
3.4 SIGNAL TERMINAL	41
3.4.1 Pulse signal (11kw and up models supported)	41
3.4.2 SI input signal	42
3.4.3 SO output signal	43
3.5 ETHERCAT COMMUNICATION CONNECTION	44
4 OPERATION TEST AND PANEL OPERATION	45
4.1 NEW MACHINE COMMISSIONING STEPS	45
4.1.1 Wiring inspection before power on & confirmation of surrounding environment	45
4.1.2 Power supply	45
4.1.3 Test run with idle shaft	46
4.1.4 Confirm the direction of motor rotation	47
4.2 OPERATING PANEL AND STATUS DESCRIPTION	48
4.2.1 Operating panel description	48
4.2.2 Operation display	48
4.2.3 Operating panel status description	49
4.2.4 Operation state display	50
4.2.5 Group U monitor parameter	51

4.2.6 Group F auxiliary parameters	54
5 ABSOLUTE VALUE SYSTEM AND POWER-OFF BRAKE	57
5.1 ABSOLUTE VALUE SYSTEM	57
5.1.1 Absolute system setting	57
5.1.2 Replace the battery	57
5.1.3 The upper limit of turns	58
5.1.4 Reset multi-turn absolute position	59
5.1.5 Zero calibration of absolute encoder	59
5.2 POWER-OFF BRAKE	61
5.3 STOP MODE	65
5.3.1 750W and below/11kw and up DS5C1 servo OFF and alarm shutdown	65
5.3.2 1~3kw DS5C1 servo OFF and alarm shutdown	66
5.3.3 Stop mode when overtravel in normal mode	68
6 ETHERCAT BUS COMMUNICATION	70
6.1 ETHERCAT TECHNICAL OVERVIEW	70
6.1.1 EtherCAT introduction	70
6.1.2 System composition(master and slave station)	70
6.2 ETHERCAT COMMUNICATION SPECIFICATION	70
6.2.1 Communication specification	70
6.2.2 EtherCAT frame structure	71
6.2.3 State machine <i>ESM</i>	72
6.2.4 Slave station controller <i>ESC</i>	72
6.2.4.1 Principle overview	72
6.2.4.2 Address space	73
6.2.5 <i>SII</i> area (0000h ~003Fh)	74
6.2.6 <i>SDO</i> (Service Data Object)	74
6.2.6.1 Mailbox frame structure	75
6.2.6.2 Mailbox overtime	75
6.2.6.3 Alarm information	76
6.2.7 <i>PDO</i> (Process Data object)	76
6.2.7.1 <i>PDO</i> mapping objects	76
6.2.7.2 <i>PDO</i> distribution objects	77
6.2.8 Communication synchronization mode	77
6.2.8.1 <i>DC</i> (<i>SYNC0</i> event synchronization)	78
6.2.8.2 <i>SM2</i> (<i>SM2</i> event synchronization)	78
6.2.9 <i>LED</i> indicator	78
7 ETHERCAT BUS CONTROL MODE	79
7.1 ETHERCAT OPERATION	79
7.2 <i>CSP</i> MODE	80
7.2.1 Related parameters	80
7.2.2 Common parameters	84
7.3 <i>CSV</i> MODE	85
7.3.1 Related parameter	85
7.3.2 Common parameters	88
7.4 <i>CST</i> MODE	89
7.4.1 Related parameter	89
7.4.2 Common parameters	92
7.5 <i>HM</i> MODE	93
7.5.1 Related parameter	94
7.5.2 Related parameters	100
7.5.3 Homing method	101
7.6 <i>PP</i> MODE	110
7.6.1 Related parameters	110
7.6.2 Common parameters	117
7.7 <i>PV</i> MODE	119
7.7.1 Related parameters	119
7.7.2 Common parameters	124
7.8 <i>TQ</i> MODE	125
7.8.1 Related parameters	125
7.8.2 Common parameters	128

7.9 MODE COMMON FUNCTION	129
7.9.1 Mode mutual switching function	129
7.9.2 Stop mode	129
7.9.3 Touch Probe function(position clamp request/release)	133
7.9.4 Digital input(60FDh)	137
7.9.5 Digital output (60FEh)	139
7.9.6 Position information	141
7.9.7 Overtravel function in Ethercat mode	148
7.9.8 Remote I/O function (version 3791 and higher supported)	154
7.9.9 Cascade alarm function	155
8 OBJECT DICTIONARY	156
8.1 OBJECT DICTIONARY AREA ASSIGNMENT	156
8.2 COE COMMUNICATION AREA (0x1000-0x1FFF)	156
8.2.1 Object list	156
8.2.2 Device information	159
8.2.3 Sync manager communication type(1C00h)	159
8.2.4 PDO mapping	160
8.2.5 Sync manager 2/3 synchronization (1C32h, 1C33h)	162
8.3 SERVO PARAMETER AREA (0x2000~0x2FFF)	166
8.3.1 Object list	166
8.3.2 Object overview	167
8.4 DRIVER PROFILE AREA(0x6000~0x6FFF)	168
8.4.1 Object list	168
8.4.2 PDS(Power Drive Systems)specification	170
8.4.3 Controlword (6040h)	171
8.4.4 Statusword (6041h)	172
8.5 CONTROL MODE SETTING	173
8.5.1 Supported drive modes (6502h)	173
8.5.2 Modes of operation(6060h)	174
8.5.3 Modes of operation display(6061h)	174
9 SERVO GAIN ADJUSTMENT	175
9.1 OVERVIEW OF SERVO GAIN ADJUSTMENT	175
9.1.1 Overview and process	175
9.1.2 Differences between these adjustment modes	176
9.2 ROTARY INERTIA PRESUMPTION	177
9.2.1 Overview	177
9.2.2 Notes	177
9.2.3 Operation tool	177
9.2.4 Operation steps	177
9.3 FAST ADJUSTMENT	181
9.3.1 Overview	181
9.3.2 Fast adjustment steps	181
9.3.3 Rigidity level corresponding gain parameters	181
9.3.4 Notes:	183
9.4 AUTO-TUNING	184
9.4.1 Overview	184
9.4.2 Notes	184
9.4.3 Operation tools	184
9.4.4 Internal instruction auto-tuning steps	184
9.4.5 External instruction auto-tuning steps	189
9.4.6 Related parameters	194
9.5 MANUAL ADJUSTMENT	195
9.5.1 Overview	195
9.5.2 Adjustment steps	195
9.5.3 Gain parameter for adjustment	196
9.6 ADAPTIVE	198
9.6.1 Overview	198
9.6.2 Notes	198
9.6.3 Operation steps	198
9.6.4 Inertia mode and related parameters	198
9.6.5 Recommended inertia ratio parameters	199

9.6.6 Adaptive parameter effect	199
9.6.7 Invalid parameters when adaptive effective	200
9.7 VIBRATION SUPPRESSION	201
9.7.1 Overview	201
9.7.2 Operation tools	201
9.7.3 Vibration suppression (panel)	201
9.7.4 Vibration suppression (PC software)	202
9.7.5 Vibration suppression(manual setting)	203
9.7.6 Vibration suppression(easy FFT)	203
9.7.7 Notch filter	205
9.8 GAIN ADJUSTMENT APPLICATION	206
9.8.1 Model loop control	206
9.8.2 Torque disturbance observation	208
9.8.3 Gain adjust parameters	208
9.8.4 Gain switch	209
9.9 GAIN ADJUSTMENT	213
9.9.1 Load shaking	213
9.9.2 Vibration	213
9.9.3 Noise	213
10 ALARM	214
10.1 ETHERCAT RELATED COMMUNICATION ALARM CODE	214
10.2 ETHERCAT COMMUNICATION UNRELATED ALARM	218
10.3 ALARM READ	227
10.4 ALARM CLEAR	227
11 APPLICATIONS	228
11.1 XINJE XG2/XDH AND DS5C1 ETHERCAT COMMUNICATION	228
11.1.1 System configuration	228
11.1.2 System topology	228
11.1.3 Debugging steps	228
11.2 BECKHOFF TWINCAT AND XINJE DS5C1	257
11.2.1 System configuration	257
11.2.2 System topology	257
11.2.3 Commissioning steps:	257
11.3 CODESYS AND XINJE DS5C1 ETHERCAT COMMUNICATION EXAMPLE	270
11.3.1 System topology	270
11.3.2 System topology	270
11.3.3 Debugging steps	270
11.4 OMRON AND DS5C1 SERVO ETHERCAT COMMUNICATION EXAMPLE	290
11.4.1 System configuration	290
11.4.2 System topology	290
11.4.3 Debugging steps	291
APPENDIX	305
APPENDIX 1. DRIVER PARAMETERS	305
Appendix 1.1 PX-XX	305
Appendix 1.2 FX-XX	317
Appendix 1.3 U0-XX	317
APPENDIX 2. OBJECT DICTIONARY	321
Appendix 2.1 COE communication area (0x1000-0x1FFF)	321
Appendix 2.2 Servo parameter area	323
Appendix 2.3 Driver Profile area(0x6000~0x6FFF)	324
APPENDIX 3. GLOSSARY OF TERMS	342

►► Confirmation on product arrival

After the product arrives, please confirm the integrity of the product in the following aspects.

Items	Notes
Does the product on arrival match the specified model?	Please confirm according to the nameplate of servo motor and servo unit.
Does the servomotor shaft rotate smoothly?	The servo motor shaft is normal if it can be turned smoothly by hand. Servo motors with brakes, however, cannot be turned manually.
Is there any damage?	Check the overall appearance, and check for damage or scratches that may have occurred during shipping.
Are there any loose screws?	Check screws for looseness using a screwdriver.
Is the motor code the same with the code in drive?	Check the motor code marked on the nameplates of the servomotor and the parameter U3-70 on the servo drive.

If any of the above is faulty or incorrect, contact Xinje or an authorized distributor.

A servo driver can be equipped with a variety of motors with similar power levels. Different types of motors are distinguished by the motor code on the motor nameplate.

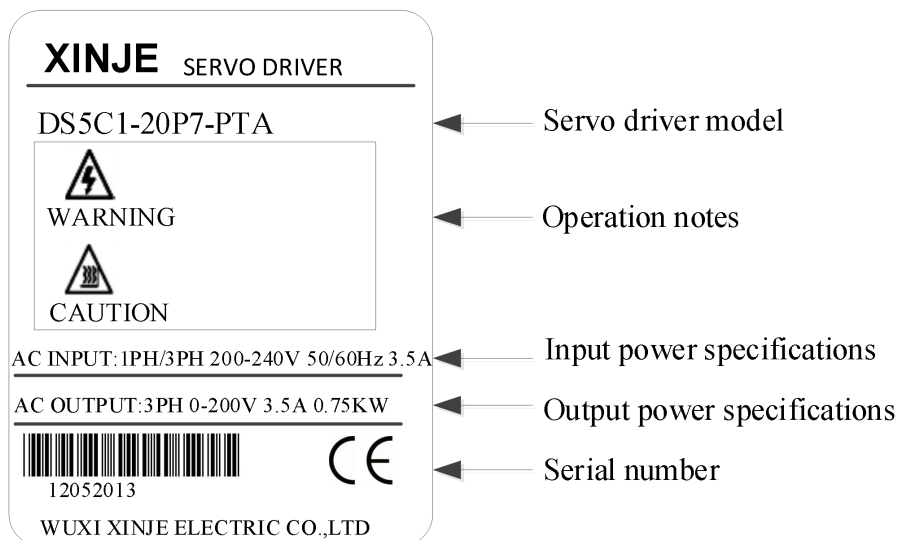
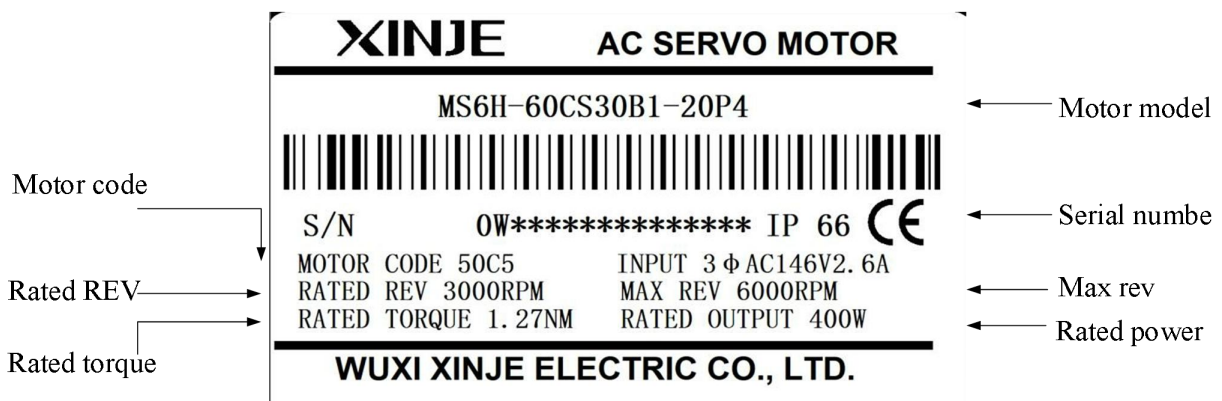

1 Selection of servo system

1.1 Selection of servo driver

1.1.1 Model name

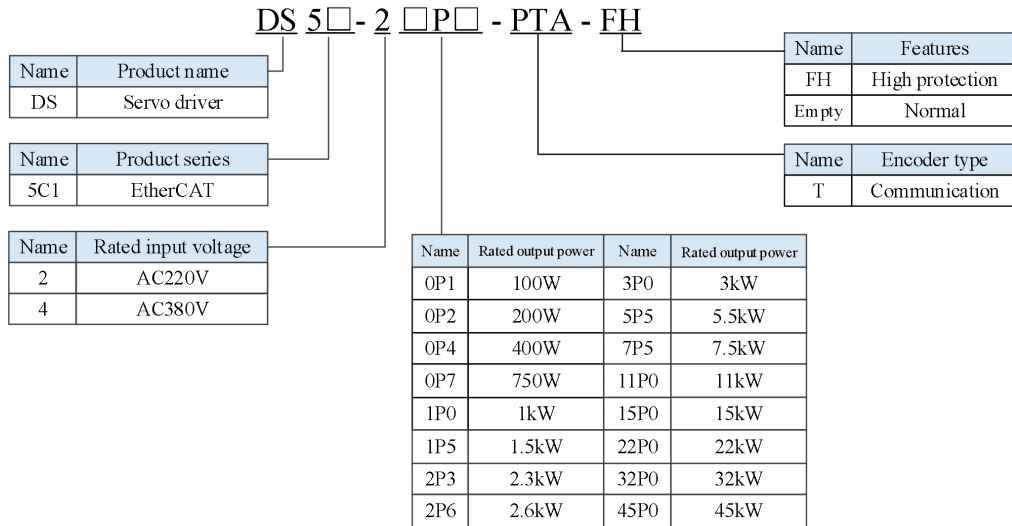

1.1.2 Description of each part

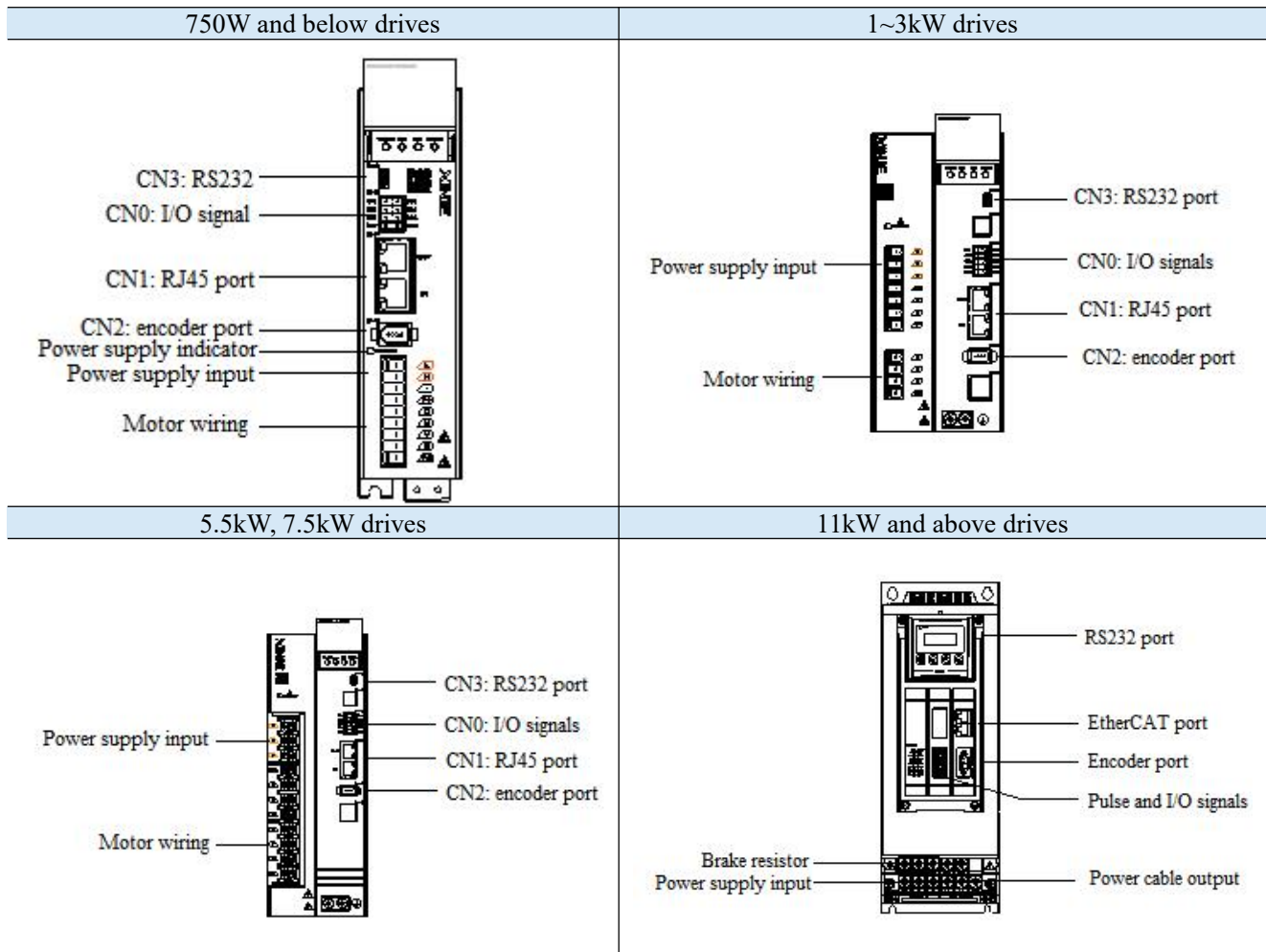

1.1.3 Performance specification

Servo unit		DS5C1 series servo driver
Applicable encoder		Standard: 17bit/23bit communication encoder
Input power supply		DS5C1-2□P□-PTA: single phase/three phase AC200~240V, 50/60Hz
		DS5C1-4□P□-PTA: Three phase AC380~440V, 50/60Hz
Control mode		Three-phase full-wave rectifier IPM PWM control sinusoidal current drive mode
Using condition	Using temperature	-10~+40 °C
	Storage temperature	-20~+60 °C
	Environment humidity	Below 90% RH (no condensation)
	Vibration resistance	4.9m/s ²
Structure		Pedestal installation

1.2 Servo motor selection

1.2.1 Model name

■ MS5 series motor

MS5S - 130 ST E - C S 02430 B Z - 2 0P7 - S01

Name	Inertia
MS5S	Low inertia
MS5G	Middle inertia
MS5H	High inertia

Display	Frame
130	130

Display	Product name
ST	Sine drive motor

Display	Product name
Empty	No oil seal
E	With oil seal

Display	Encoder type
C	Magnetic encoder
T	Photoelectric encoder

Display	Encoder accuracy
S	Single circle 17-bit
M	Multi-circle 17-bit
U	Single-circle 23-bit
L	Multi-circle 23-bit

Display	Design number
S01	Standard
S02	Small aviation plug type

Display	Rated power(KW)
2P3	2.3
3P0	3.0

Display	Voltage level
2	220V
4	380V

Display	Power-off brake
Empty	without
Z	with

Display	Shaft
A	No key
B	With key

Name	Rated torque(N·m)	Rated speed (rpm)
00630	0.637	3000
01330	1.27	3000
02430	2.39	3000

Note: At present, only the combination of CS, CM, TL and T is selected for the type of encoder.

■ MS6 series motor

MS6S - 60 C S 30 B Z 1 - 2 0P4

Display	Inertia
MS6S	Low inertia
MS6H	High inertia

Display	Frame
40	40 seat
60	60 seat
80	80 seat
100	100 seat
130	130 seat
180	180 seat

Display	Encoder type
C	Magnetic encoder
T	Photoelectric encoder

Display	Encoder accuracy
S	Single circle 17-bit
M	Multi-circle 17-bit
U	Single-circle 23-bit
L	Multi-circle 23-bit

Display	Rated speed(rpm)
15	1500
20	2000
25	2500
30	3000

Display	Rated power(KW)	Display	Rated power(KW)
0P1	100W	1P8	1.8KW
0P2	200W	2P3	2.3KW
0P4	400W	3P0	3.0KW
0P7	750W	4P4	4.4KW
0P8	850W	5P5	5.5KW
1P5	1.5KW	7P5	7.5KW

Display	Voltage level
2	220V
4	380V

Display	Connector type
1	AMP plug
2	Aviation plug
3	Connector

Display	Power-off brake
Vacant	Without brake
Z	With brake

Display	Shaft specification
A	With key, no oil seal ,with threaded hole
B	With key,with oil seal,with threaded hole
C	No key, no oil seal, with threaded hole
D	No key, with oil seal, with threaded hole
E	Special shaft specification(length,shaft diameter,etc.)

1.2.2 Description of each part

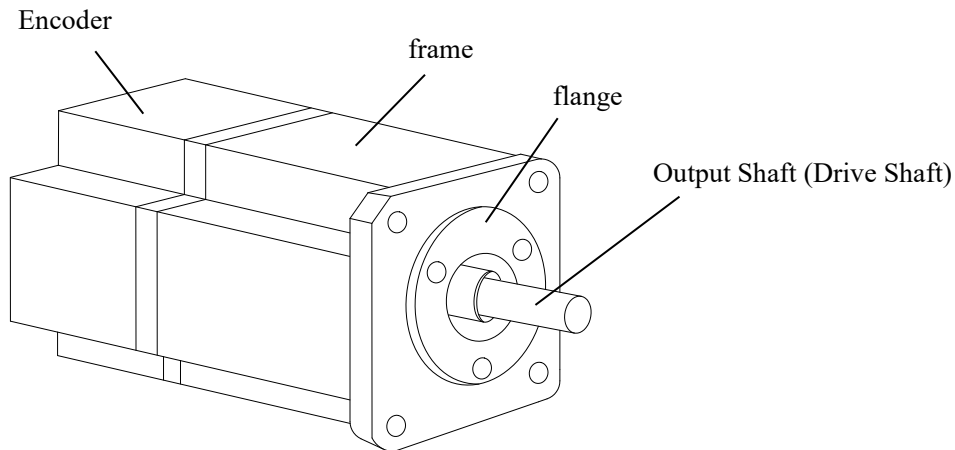

1.2.3 Axial force and radial force

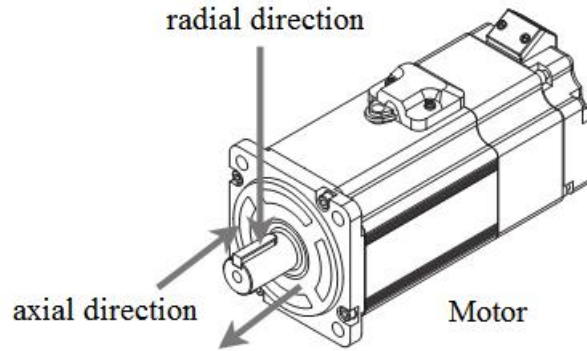

Base no.	40ST	60ST	80ST	100ST	110ST	130ST	180ST	220ST/265ST
Axial force	54N	74N	147N	≤200N	250N	300N	400N	≤500N
Radial force	78N	245N	392N	500N	500N	600N	800N	1000N

1.3 Cable selection

1.3.1 Encoder cable

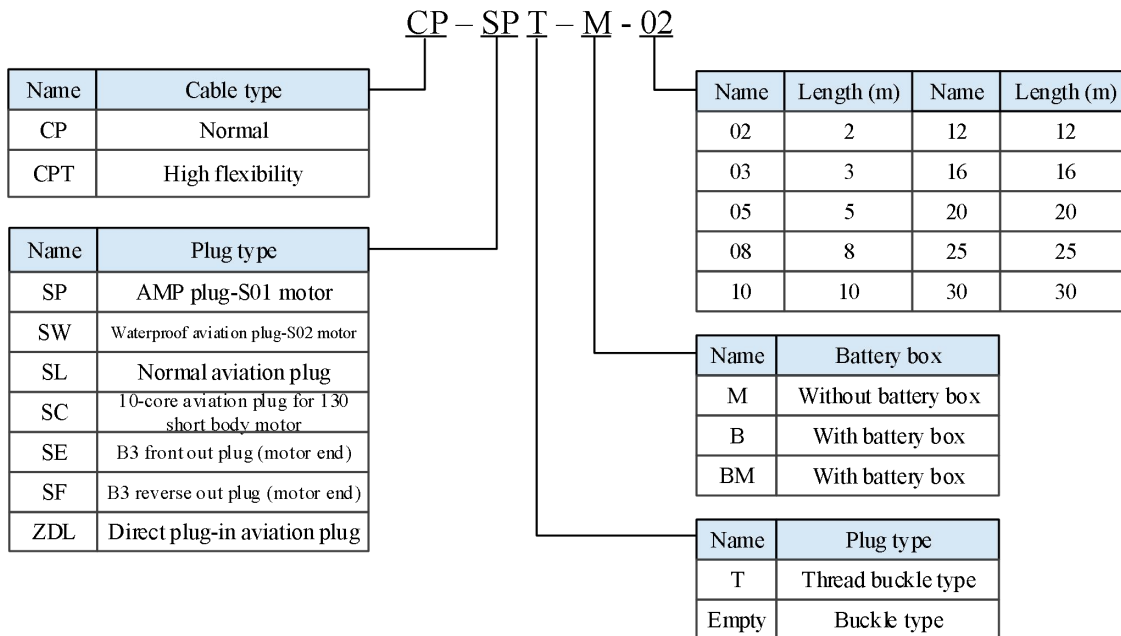

Note: The ZDL series encoder cables are equipped with temperature sensors by default.

1.3.2 Power cable

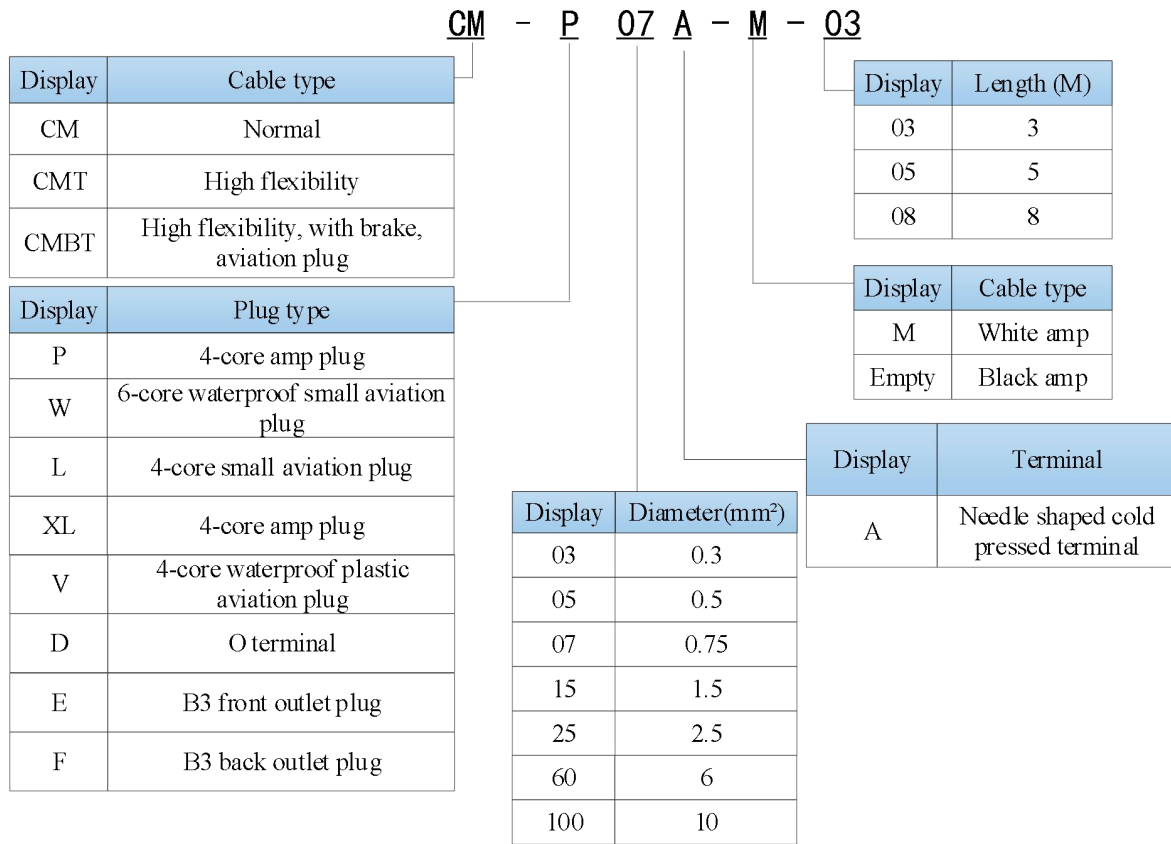

1.3.3 EtherCAT communication cable

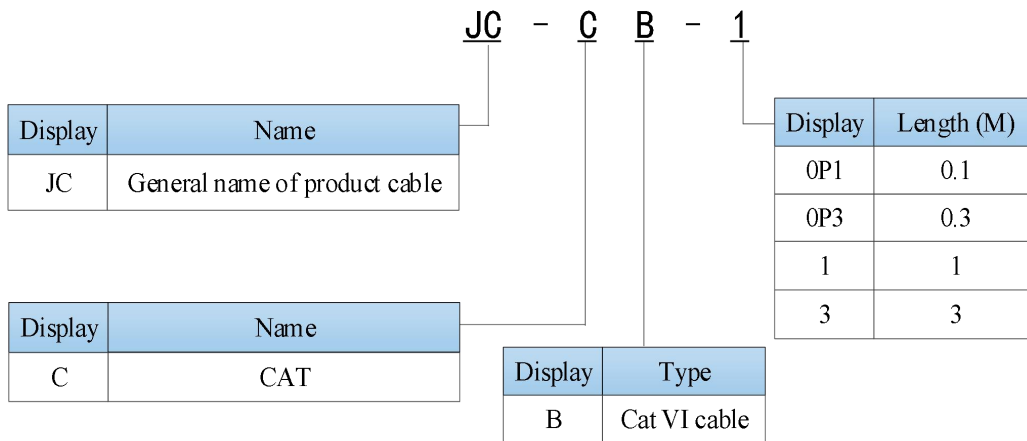

Note: At present, the length of communication cables is 0.2 m, 0.3 m, 0.5 m, 1 m, 3 m, 5 m, 10 m, 20 m.

1.3.4 Description of each part

Encoder cable

(1) Pin definition of encoder on servo driver side

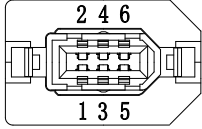
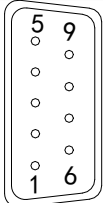
 7.5kW and below	Pin definition			
	No.	Name	No.	Name
 11kW and up	1	5V	4	/
	2	GND	5	485-A
	3	/	6	485-B
	No.	Name	No.	Name
	1	Temperature sensor	6	GND
	2	Temperature sensor	7	/
	3	485-B	8	5V
	4	485-A	9	/
	5	Shield wire	-	-

(2) Cable connection of encoder on motor side

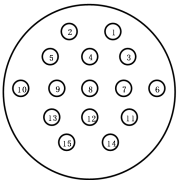
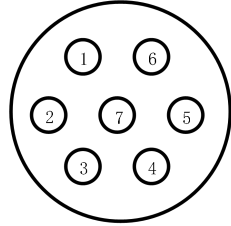
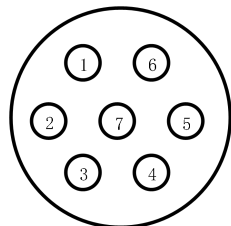
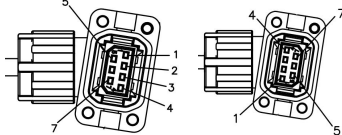
Motor model	Connector	Pin definition	
		No.	Name
MS6-40, 60, 80 base B1/B4 motor MS5-40, 60, 80 base S01 motor		1	Battery +
		2	Battery -
		3	Shielding wire
		4	485-A
		5	485-B
		6	/
		7	5V
		8	GND
		9	/
MS5-40, 60, 80 base S02 motor		No.	Name
		1	Shielding wire
		2	Battery +
		3	Battery -
		4	485-A
		5	485-B
		6	5V
7	GND		
MS6-60, 80 base B2 motor		No.	Name
		1	GND
		2	Battery +
		3	Battery -
		4	485-A
		5	485-B
		6	5V
7	Shielding wire		
MS6-40, 60, 80 base B3 motor	 Forward outlet reverse outlet (user's view)	No.	Name
		1	5V
		2	GND
		3	Battery +
		4	Battery -
5	485-A		

Motor model	Connector	Pin definition	
		6	485-B
		7	Shielding wire

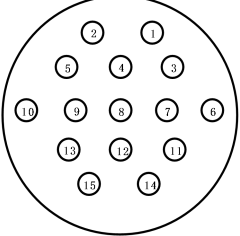
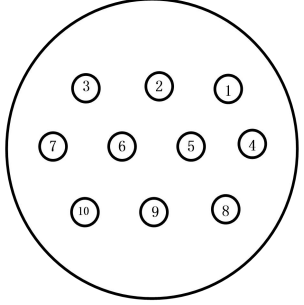
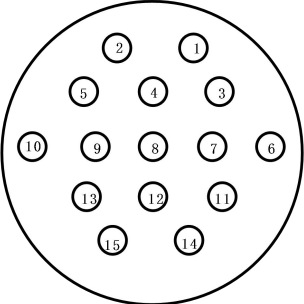
MS6-180 B2 motor MS5-110, 180 S01 motor MS-110, 130 absolute value motor		1	Shielding wire
		2	/
		3	485-A
		4	485-B
		5	/
		6	GND
		7	Battery -
		8	5V
		9	Battery +
		MS6-100, 130 motor MS5-130 motor	
1	/		
2	5V		
3	GND		
4	485-A		
5	485-B		
6	Battery +		
7	Battery -		
8	/		
9	/		
220/265 motor		No.	Name
		1	Shielding wire
		2	/
		3	485-B
		4	485-A
		5	/
		6	GND
		7	Battery -
		8	5V
		9	Battery +
		14	Temperature -
		15	Temperature +

Battery box description:

(1) The encoder including the cable definition of battery +, battery- is for the absolute motor, and the non-absolute motor cable has no such pin.

(2) Only the cable of absolute value motor has external battery box, which contains a 3.6V/2.7Ah large capacity battery, and has the function of replacing batteries when power on. The using life is more than two years.

■ Power cable

(1) Pin definition of power cable on servo driver side



Connector appearance	Pin definition	
	Color	Definition
	Brown	U
	Black	V
	Blue	W
	Yellow-green	PE

	Color	Definition
	Red	U
	White	V
	Black	W
	Yellow green	PE
	Blue	BK+
	Brown	BK-

(2) Power cable connection on motor side

Motor model	Connector	Pin definition	
		No.	Name
MS6-40, 60, 80 base B1/B4 motor MS5-40, 60, 80 base S01 motor		1	U
		2	W
		3	V
		4	PE
MS6-40, 60, 80 base B1/B4 brake motor MS5-40, 60, 80 base S01 brake motor		No.	Name
		1	BK+
		2	BK-
MS5-40, 60, 80 base S02 motor		No.	Name
		1	PE
		2	U
		3	V
		4	W
		5	BK+
MS6-40, 60, 80 base B2 motor		No.	Name
		1	U
		2	W
		3	V
MS6-40, 60, 80 base B2 brake motor		No.	Name
		1	U
		2	W
		3	V
		4	PE
		5	BK+
MS6-40 base B3 motor		No.	Name
		1	W
		2	V
		3	U
		4	PE
		5	BK+
6	BK-		

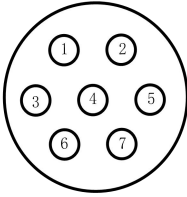
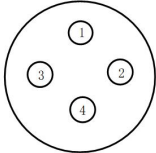
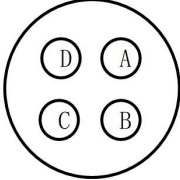
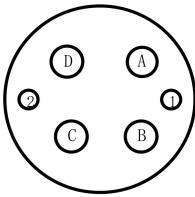
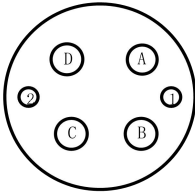
Motor model	Connector	Pin definition	
		No.	Name
MS6-60, 80 base B3 motor		1	U
		2	V
		3	W
		4	PE
		A	BK+

Motor model	Connector	Pin definition	
		No.	Name
	Forward outlet reverse outlet (user's view)	B	BK-
MS6-100, 130 base non medium inertia brake motor MS5G-130 base medium inertia brake motor		No.	Name
		1	PE
		2	U
		3	V
		4	W
		5	BK+
		6	BK-
		7	/
MS6-100, 130, 180 base non medium inertia non brake motor MS5-110, 130, 180 base non brake motor MS-110, 130 base non brake absolute motor		No.	Name
		1	PE
		2	U
		3	V
		4	W
MS6G-110, 130 base medium inertia non brake motor		No.	Name
		A	W
		B	V
		C	U
		D	PE
MS6G-110, 130 base medium inertia brake motor		No.	Name
		A	W
		B	V
		C	U
		D	PE
		1	BK+
		2	BK-
		MS6, MS5-180 base brake motor	
A	U		
B	V		
C	W		
D	PE		
1	BK+		
2	BK-		
220/265 motor		Color	Name
		Red	U
		Green	V
		Blue	W
		Yellow green	PE

Brake pins:

The cable including pin BK+, BK- is used for the brake motor. The cable of the non-brake motor has no BK pins.

1.4 Selection of other accessories

When the servo motor is driven by the generator mode, the power returns to the servo amplifier side, which is called regenerative power. The regenerated power is absorbed by charging the smooth capacitor of the servo amplifier. After exceeding the rechargeable energy, the regenerative resistance is used to consume the regenerative power.

- ◆ The deceleration stop period during acceleration and deceleration operation.
- ◆ Running vertically and axially.
- ◆ When the external load drives the motor to rotate.

Servo driver model	Regenerative resistance connection terminals
DS5C1-□□P□-PTA	1) using built-in regenerative resistance, short P+ and D terminals, P+ and C are disconnected. 2) Use an external braking resistor for 7.5kW and below. Connect the braking resistor to the P+ and C terminals, remove the P+ and D short circuits, P0-25=power value, P0-26=resistance value; 11kW and above use an external braking resistor to connect the braking resistor to the P+ and PB terminals, P0-25=power value, P0-26=resistance value.

The following table is the recommended specifications of external regenerative resistance for each type of motor.

Servo driver model	Built-in brake unit	Minimum resistance(no less than this value)	External regenerative resistance(recommended resistance value)	External regenerative resistance(recommended power value)
DS5C1-20P1-PTA	/	80Ω	80Ω-100Ω	Above 200W
DS5C1-20P2-PTA	/			
DS5C1-20P4-PTA	/			
DS5C1-20P7-PTA	80W50Ω	50Ω	50Ω-100Ω	Above 600W
DS5C1-21P0-PTA	80W45Ω	35Ω	35Ω-75Ω	Above 800W
DS5C1-21P5-PTA	80W50Ω	30Ω	30Ω-50Ω	Above 1000W
DS5C1-22P3-PTA	80W50Ω			
DS5C1-22P6-PTA	80W50Ω	25Ω	25Ω-50Ω	
DS5C1-41P0-PTA	80W100Ω	120Ω	120Ω-150Ω	Above 800W
DS5C1-41P5-PTA	80W100Ω	75Ω	75Ω-120Ω	Above 1000W
DS5C1-42P3-PTA	80W60Ω	55Ω	55Ω-75Ω	Above 1000W
DS5C1-43P0-PTA	80W60Ω	50Ω	50Ω-75Ω	Above 1200W
DS5C1-45P5-PTA	/	25Ω	25Ω-65Ω	Above 2000W
DS5C1-47P5-PTA	/	22Ω	22Ω-50Ω	Above 2500W
DS5C1-411P0-PTA	/	20Ω	20Ω-45Ω	Above 3000W
DS5C1-415P0-PTA	/	20Ω	20Ω-45Ω	Above 3000W
DS5C1-422P0-PTA	/	20Ω	20Ω-30Ω	Above 5000W
DS5C1-432P0-PTA	/	20Ω	20Ω-30Ω	Above 5000W
DS5C1-445P0-PTA	/	6Ω (Overspeed motor) 8Ω (normal motor)	6Ω-12Ω (Overspeed motor) 8Ω-16Ω (normal motor)	Above 15000W(overspeed motor) Above 10000W (normal motor)

Note:

1) When selecting external resistance, "resistance" - try to choose close to the "minimum resistance" in the "recommended resistance". The smaller the resistance, the faster the discharge will be. The selection of "power" should be based on the actual use on site, and the specific should depend on the calorific value. Generally, the external regenerative resistor with higher power should be selected as far as possible.

2) The surface temperature of the regenerative resistance will be very high when it is frequently discharged. Please use high-temperature resistant and flame-retardant wires when wiring, and note that the surface of the regenerative resistance can not contact with the wire.

2 Installation of servo system

2.1 Servo driver installation

2.1.1 Installation site

- ◆ Please install it in the installation cabinet without sunshine or rain.
- ◆ Do not use this product near corrosive and flammable gas environments and combustibles such as hydrogen sulfide, chlorine, ammonia, sulfur, chlorinated gas, acid, alkali, salt, etc.
- ◆ Do not install in high temperature, humidity, dust, metal dust environment.
- ◆ No vibration place.

2.1.2 Environment condition

Item	Description
Using ambient temperature	-10~40°C
Using ambient humidity	20~90%RH (no condensation)
Storage temperature	-20~60°C
Storage humidity	20~90%RH (no condensation)

2.1.3 Installation standard

Please be sure to comply with the installation standard in the control cabinet shown in the figure below, which is applicable to the situation where multiple servo drives are installed side by side in the control cabinet (hereinafter referred to as "side by side installation").

- 3kW and below drivers

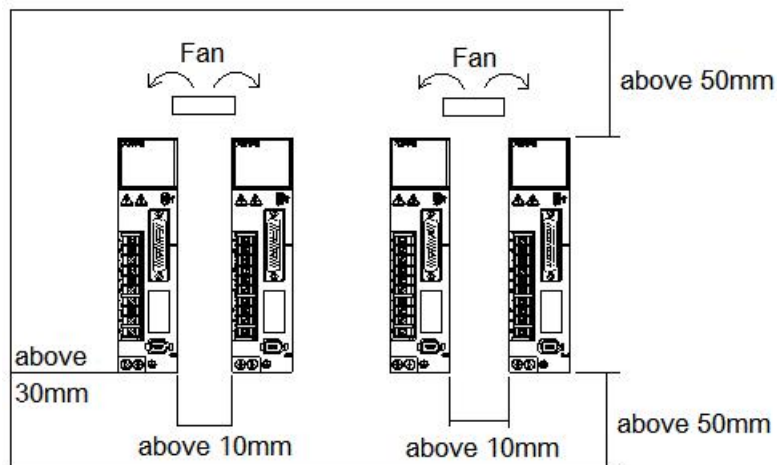

- 5.5, 7.5kW and below drivers

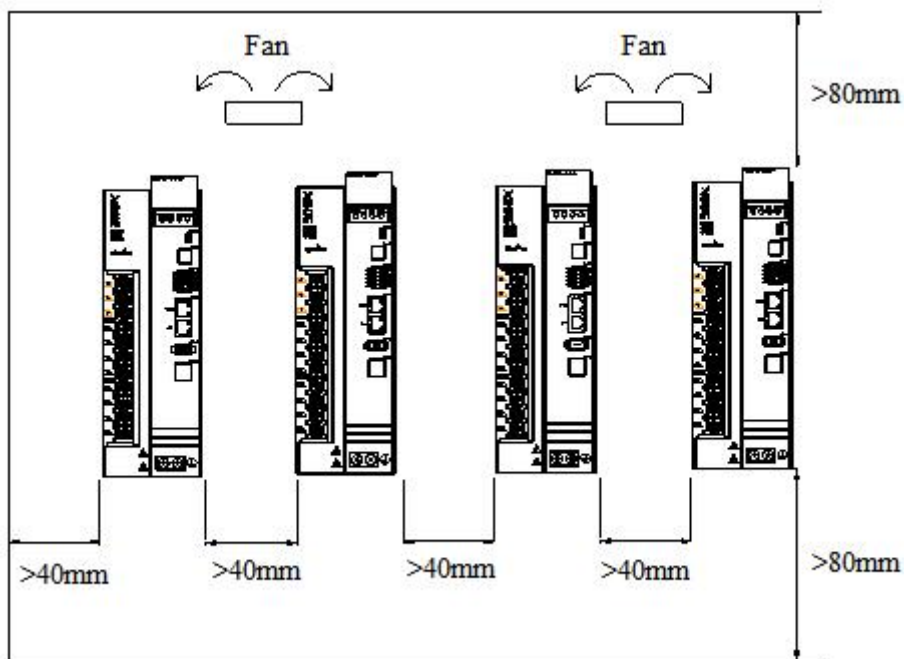

■ 11kW and up drivers

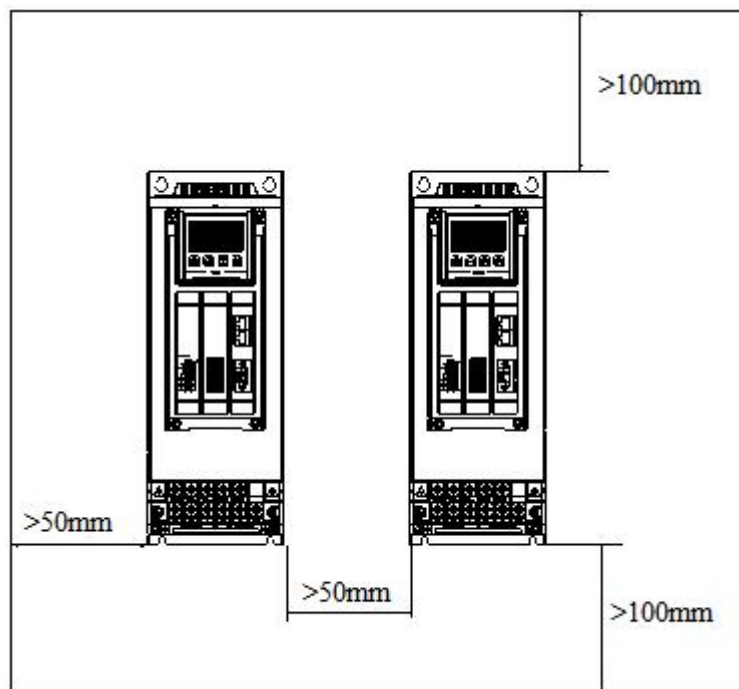

■ Servo driver orientation

When installing, please make the front of the servo driver (the actual installation surface of the operator) face the operator and make it perpendicular to the wall. For drives with regenerative resistors at the bottom, please pay attention to the heat dissipation of the mounting surface to avoid overheating and fire.

■ Cooling

As shown in the figure above, allow sufficient space around each servo drive for cooling by fans or natural convection.

■ Side-by-side installation

When install servo drives side by side as shown in the figure above, make at least 10mm between and at least 50mm above and below each servo drive. Install cooling fans above the servo drives to avoid excessive temperature rise and to maintain even temperature inside the control panel. Drivers with a power output of 11kW and above must be at least 50mm horizontally from the installation cabinet on both sides, and at least 100mm

vertically from the installation cabinet on both sides. In addition, in order to prevent local overheating of the servo drive environment, it is necessary to maintain a uniform temperature inside the control cabinet.

■ Environmental conditions in the control panel

- ◆ Servo driver working ambient temperature: -10~40°C.
- ◆ Humidity: Below 90%RH(relative humidity)
- ◆ Vibration: 4.9m/s²
- ◆ Condensation or freezing: None
- ◆ In order to ensure the reliability of long-term use, please use it at an ambient temperature lower than 50°C.

2.2 Servo motor installation

MS5/MS6 series servo motors can be installed either horizontally or vertically. The service life of the servo motor can be shortened or unexpected problems might occur if it is installed incorrectly or in an inappropriate location. Follow the installation instructions carefully.

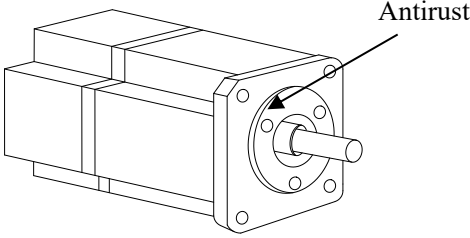

Caution

1. The shaft end is coated with antirust. Please wipe the "antirust" with a cloth soaked in "thinner" before installing the motor.
2. Avoid getting thinner on other parts of the servo motor.

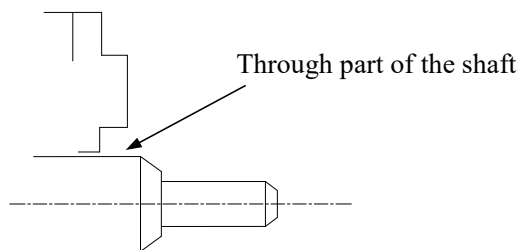

2.2.1 Environment condition

When used in places with water droplets or oil droplets, the protection effect can be achieved through the treatment of motors. However, in order to seal the through part of the shaft, please specify the motor with oil seal. Connectors should be installed downward.



MS5/MS6 series servo motors are intended for indoor use. Please use them in an environment that meets the following installation conditions.

Item	Description
Using ambient temperature	-10°C~40°C(no freeze)
Using ambient humidity	20%~90%RH(no condensation)
Storage temperature	-20°C~60°C
Storage humidity	20%~90%RH(no condensation)
Protection level	IP65(MS5)/ IP66(MS6-40/60/80)/ IP67(MS6-B3/B4, MS6G)

2.2.2 Installation cautions

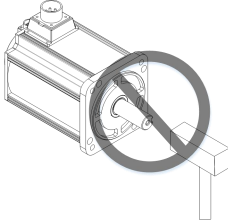
Item	Description
Antirust treatment	<ul style="list-style-type: none"> ◆ Please wipe the "antirust" on the shaft extension end of the servo motor before installation, and then do relevant rust prevention treatment.
Encoder cautions	<ul style="list-style-type: none"> ◆ Do not hit the shaft extension end during installation, otherwise the internal encoder will be broken. 
	<ul style="list-style-type: none"> ◆ When installing a pulley on a servo motor shaft with a keyway, a screw hole is used at the shaft end. To install the pulley, first insert the stud into the screw hole of the shaft, use a washer on the surface of the coupling end, and gradually lock the pulley with a nut. ◆ For the servo motor shaft with keyway, use the screw hole at the end of the shaft to install. For shaft without keyway, friction coupling or similar methods are used. ◆ When disassembling the pulley, use the pulley extractor to prevent the shaft from bearing the strong impact of the load. ◆ To ensure safety, install protective covers or similar devices in the rotating area, such as pulleys installed on shafts

2.2.3 Installation environment

- Do not use this product near corrosive and flammable gas environments and combustibles such as hydrogen sulfide, chlorine, ammonia, sulfur, chlorinated gas, acid, alkali, salt, etc.
- Please choose motor with oil seal in places with grinding fluid, oil mist, iron powder, cutting, etc.
- In places with grinding fluid, oil mist, iron powder, cutting, etc., please choose motor with oil seal.
- Keep away from furnaces and other heat sources.
- Do not use the motor in a closed environment. The enclosed environment will lead to high temperature of the motor and shorten its service life.

2.3 Servo cable installation

DS5 series servo motor adopts communication encoder, which may cause uncertain influence due to improper use and environmental factors. When installing power cable and encoder cable, please pay attention to the following instructions.

2.3.1 Cable selection

Our regular cable materials include ordinary cable and high flexible cable. The adapter cable connector for motors with 80 flange or less is divided into aviation plug and amp plug; the adapter cable connector for motors with 80 flange or more is aviation plug.

The cable selected by the customer needs to define the operating conditions on site.

If the cable is used in general occasions, please select the cable from other manufacturers (2.3.2 specifications of Xinje cable) in strict accordance with the specifications given by Xinje. If the cable is used in unconventional occasions, please select the cable according to the actual working conditions to be superior to the existing specifications of Xinje.

1. In normal situations, the following points should be noted:

- ◆ For pulse command signal cable, please ensure wiring less than 3m.
- ◆ The encoder cable shall be within 20 meters. It is recommended to select special cable if it is more than 20 meters. The wire diameter of encoder cable depends on the length of encoder cable used on site. The longer the cable is, the greater the wire resistance is, and the more severe the voltage attenuation or signal distortion is, which is likely to cause pulse loss or no signal can be detected. Therefore, in general, the customized special cable should be selected if it is more than 20 meters.
- ◆ The power cable diameter depends on the current condition of the motor. Generally, the wire diameter is 1/10 of the maximum current of the motor. For example, the maximum current of the motor is 60A, and the wire diameter of 6mm² is selected.
- ◆ In case of interference, it is necessary to separate strong and weak current. It is recommended to separate power cable from encoder cable and signal cable.
- ◆ Ensure the correct grounding of servo driver and servo motor. The grounding resistance is not more than 4Ω, and the grounding depth is more than 2m. It is recommended to use 4*40 angle galvanized steel or 40mm diameter galvanized steel pipe;
- ◆ If the customer makes the wire by himself, the cable specification please refer to chapter 2.3.2 Xinje cable specification, the welding reliability shall be ensured when making the wire to avoid false welding, bridge connection, wrong welding, missing welding, etc., and the continuity of both ends of the cable can be tested after the welding is completed.

2. In unconventional occasions, the following items shall be noted:

(1) Occasions of dragging and bending cables

- ◆ Do not bend the cable or bear the tension. As the core diameter of signal cable is only 0.2mm or 0.3mm, it is easy to break, please pay attention to it when using.
- ◆ When the cable needs to be moved, please use flexible cable. Ordinary cable is easy to be damaged after long-term bending. Small power motor (motor below 80 flange) with its own cable can not be used for cable movement.
- ◆ When using cable protection chain, please ensure that:
 - ① The bending radius of the cable is more than 10 times of the outer diameter of the cable;
 - ② The wiring in the cable protection chain shall not be fixed or bundled, only the two immovable wires end in the cable protection chain shall be bound and fixed;
 - ③ Do not twist the cable;
 - ④ The duty cycle in the cable protection chain shall be less than 60%;
 - ⑤ Do not mix the cables with too big difference in appearance. The thin wire will be broken by the thick wire. If it is necessary to mix the wiring, partition device is arranged in the middle of the cable.

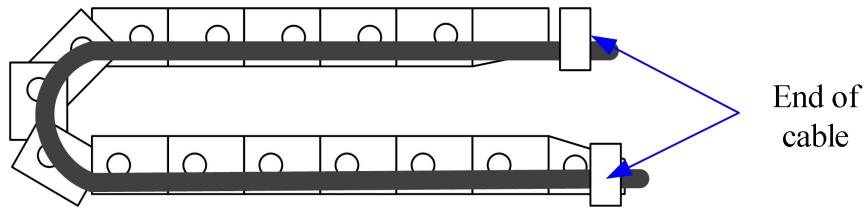

(2) Greasy and humid occasions

- ◆ It is recommended to select cable with aviation plug as connector instead of AMP interface cable.
- ◆ It is necessary to make corresponding protection (glass glue/insulating cloth binding, etc.) for the used AMP interface cable on site.
- ◆ Use special cable.

(3) Interference, high current / high power occasions (such as welding equipment)

- ◆ The motor is properly grounded.
- ◆ High current equipment shall be grounded separately.
- ◆ Reasonable wiring. Such as separation of strong and weak current cables.
- ◆ Use metal shielding layer to shield, add magnetic ring to the encoder cable to resist interference.

(4) Low / high temperature

- ◆ Select cables (special cables) that meet the use conditions.

2.3.2 Xinje cable specification

1. Material composition of Xinje cable

Cross section of cable (encoder, power cable), corresponding introduction of wire skin material, wire diameter, wire core material shielding material, etc.

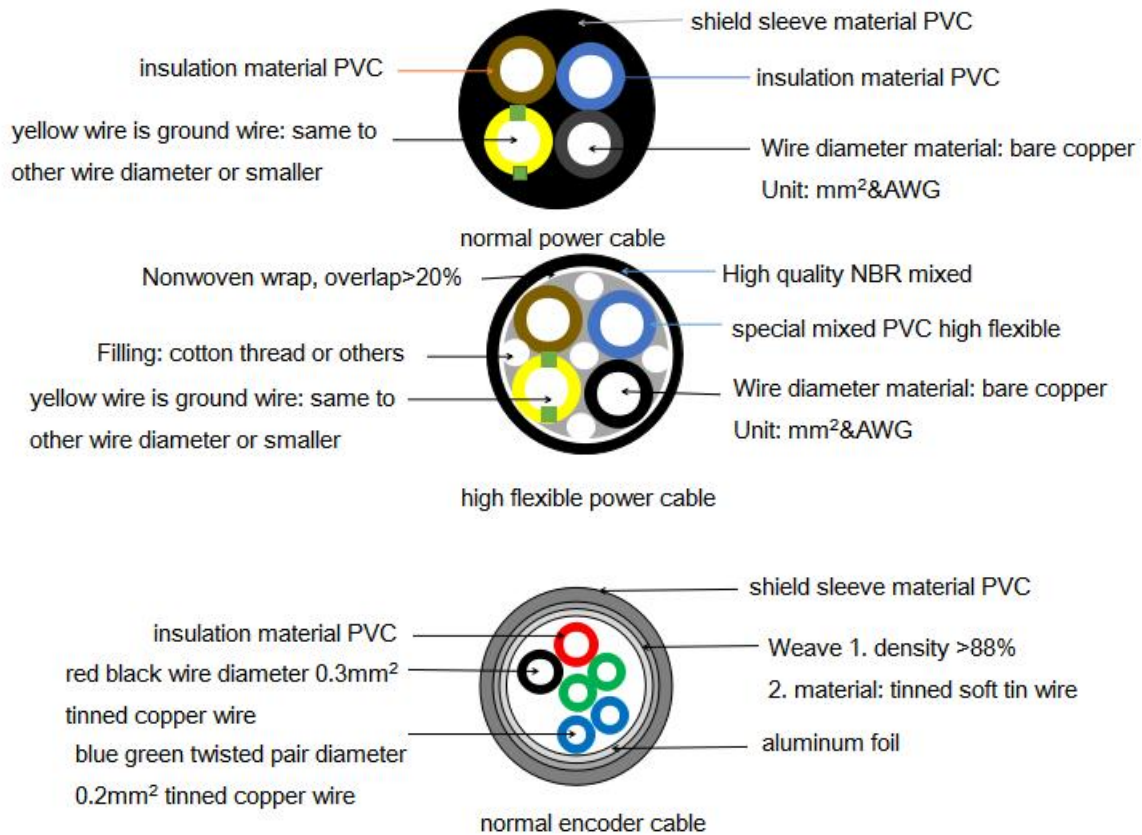

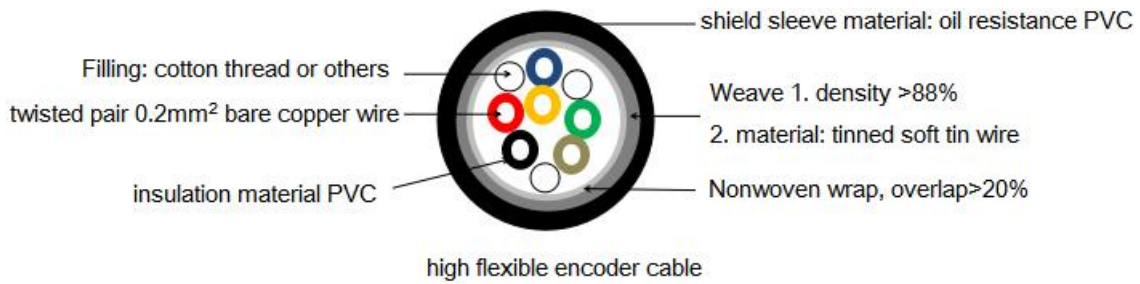

2. Cable diameter specification

Length	Base	Encoder cable diameter			Power cable diameter		
		Type	Whole cable diameter (mm)	Single cable diameter (mm ²)	Type	Whole cable diameter (mm)	Single cable diameter (mm ²)
20m and below	80 and below	Normal without battery box/with battery box	5.8/6.4	3P*0.2mm ²	Normal / High flexibility	7.2/7.0	4*0.75mm ²
	110, 130		6.2/6.2		Normal / High flexibility	9.4/9.6	4*1mm ²
	180 base 2.9kW, 3kW	High flexibility	6.2		Normal / High flexibility	11.4/11.9	4*2mm ²
					Normal / High flexibility	14.5/15.6	4*6mm ²
	220 base 22kW and below 32kW 45kW	High flexibility	7.9		Normal	19.8	4*10mm ²
					Normal	20	3*12mm ² +1*4mm ²
					Normal	29	3*30mm ² +1*16mm ²
25m, 30m	180 base and below	Normal / High flexibility	7.8/6.8	2P*0.2mm ² +1P*0.34mm ²	/	/	/
	220 base	High flexibility	7.9	3P*0.2mm ² +1P*0.4mm ²	/	/	/

3. Cable performance specification

Performance		Normal cable	High flexible cable
Ordinary temperature resistance		-20°C~80°C	-20°C~80°C
Encoder cable withstand voltage		1000V/min	1000V/min
Power cable withstand voltage		3000V/min	3000V/min
Mobile installation	Bending radius	Travel <10m, 7.5*D; Travel ≥10m, 10*D;	Travel <10m, 7.5*D; Travel ≥10m, 10*D;
	Bending resistance times	Travel <10m, ≥1 million times; Travel ≥10m, ≥2 million times;	Travel <10m, ≥3 million times; Travel ≥10m, ≥5 million times;
Fixed installation	Bending radius	5*D	5*D

Note: D represents the finished product cable diameter.

2.4 Servo driver dimension

■ DS5C1-20P1/20P2/20P4-PTA

unit: mm

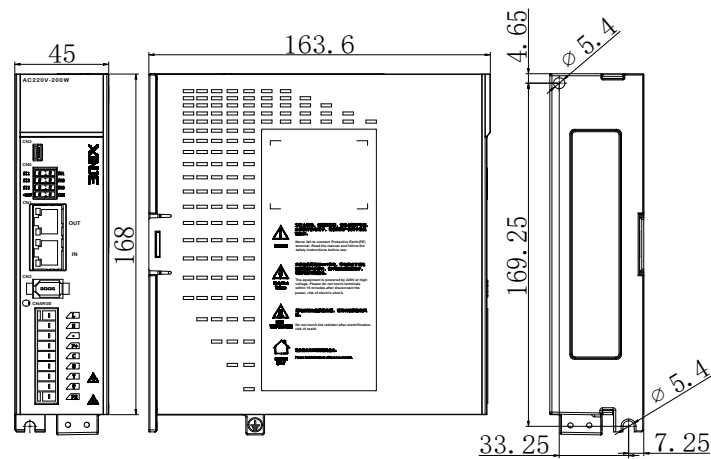

■ DS5C1-20P7-PTA

unit: mm

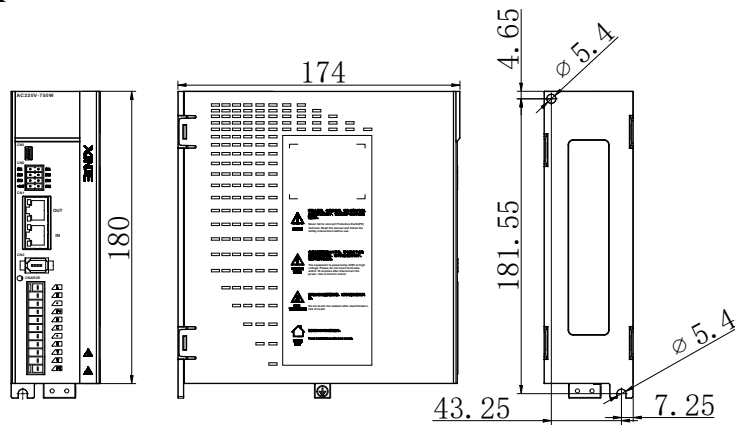

■ DS5C1-21P0/41P0/41P5-PTA

unit: mm

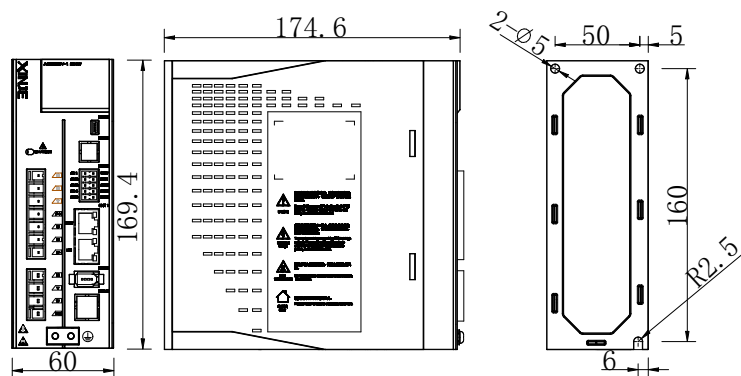

■ DS5C1-21P5/22P3/22P6/42P3/43P0-PTA

unit: mm

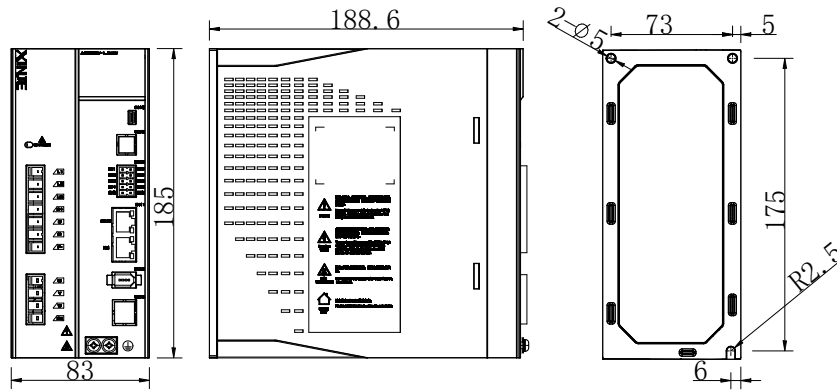

■ DS5C1-45P5/47P5-PTA

unit: mm

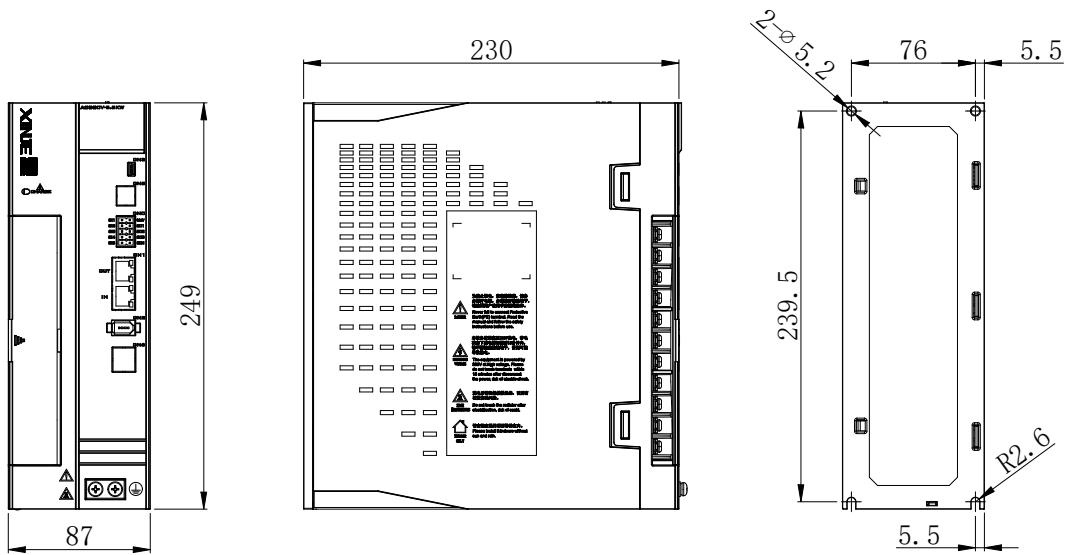

■ DS5C1-411P0-PTA, DS5C1-415P0-PTA

unit: mm

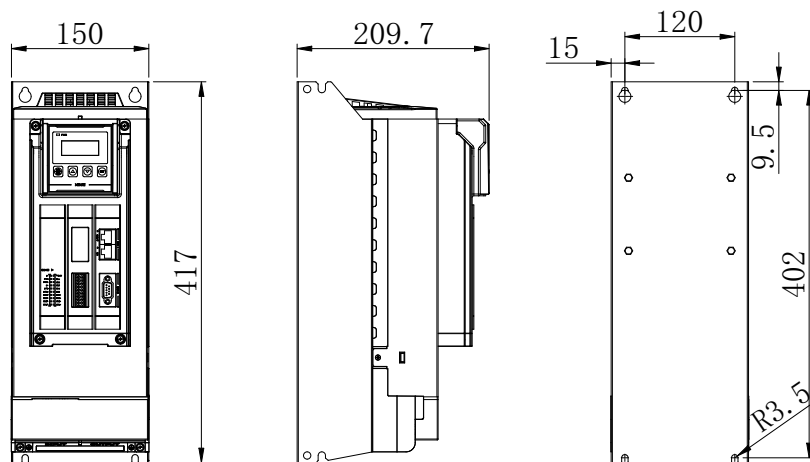

■ DS5C1-422P0-PTA, DS5C1-432P0-PTA

unit: mm

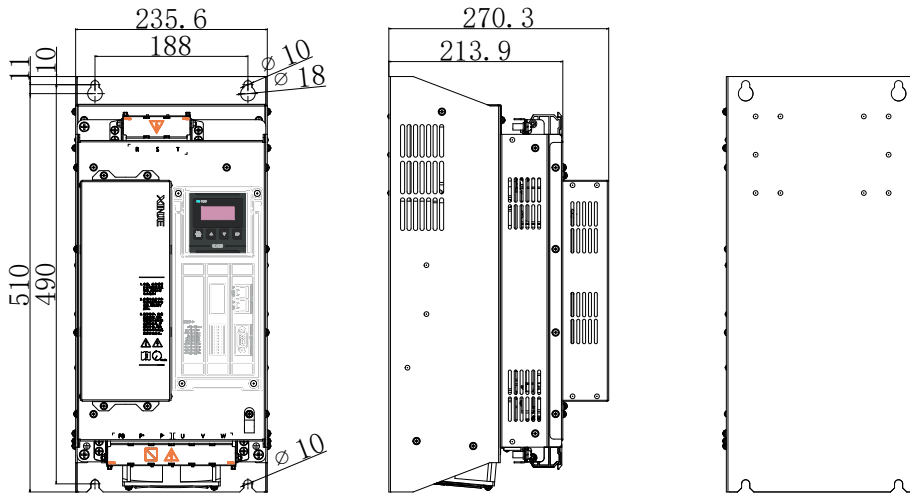

■ DS5C1-445P0-PTA

unit: mm

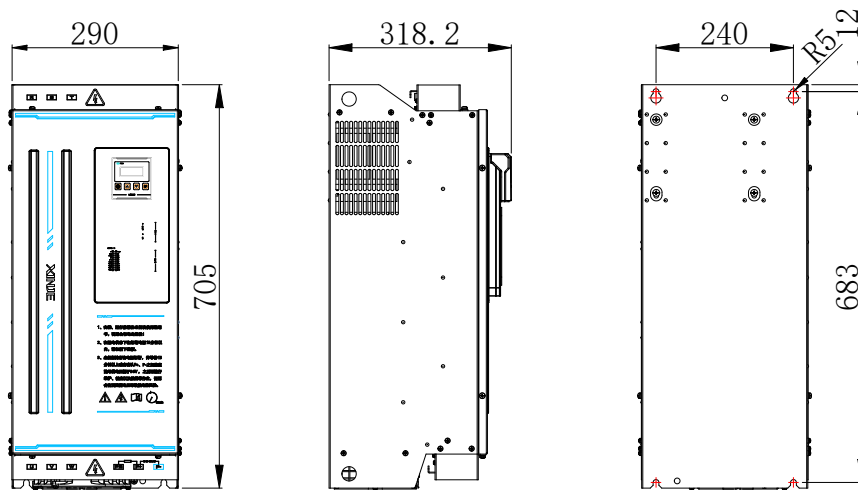

2.5 Servo motor dimension

■ 40 series motor installation dimensions Unit: mm

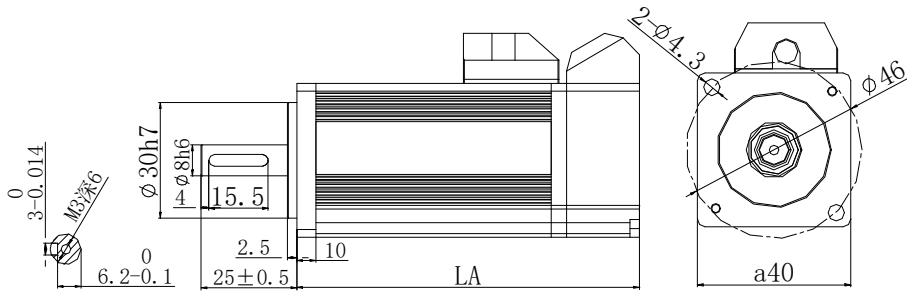

Motor model	LA±1		Inertia level
	Normal	With brake	
MS5S-40ST-C□00330□□-20P1-S01/S02	89.5	119	Low inertia

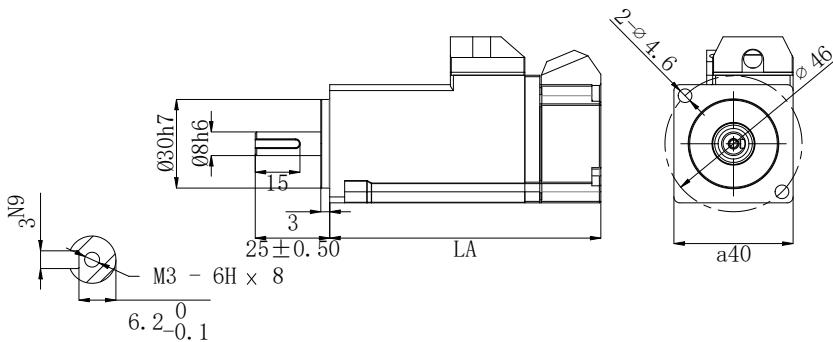

Motor model	LA±1		Inertia level
	Normal	With brake	
MS6H-40C□30B□1-20P1	91	122.9	High inertia

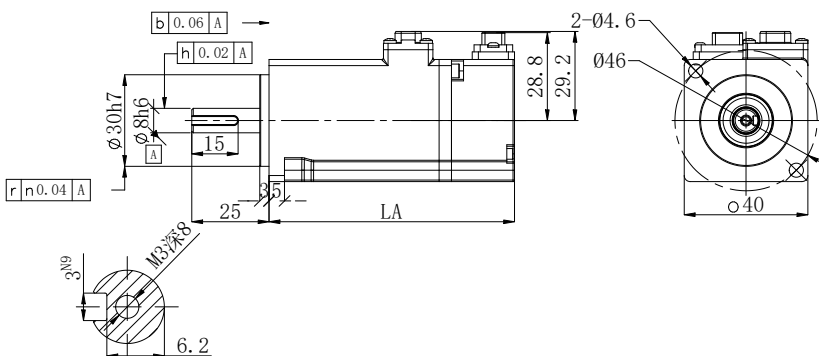

Motor model	LA±1		Inertia level
	Normal	With brake	
MS6H-40□□30B□3-20P1	79.4	112	High inertia

■ 60 series motor installation dimensions Unit: mm

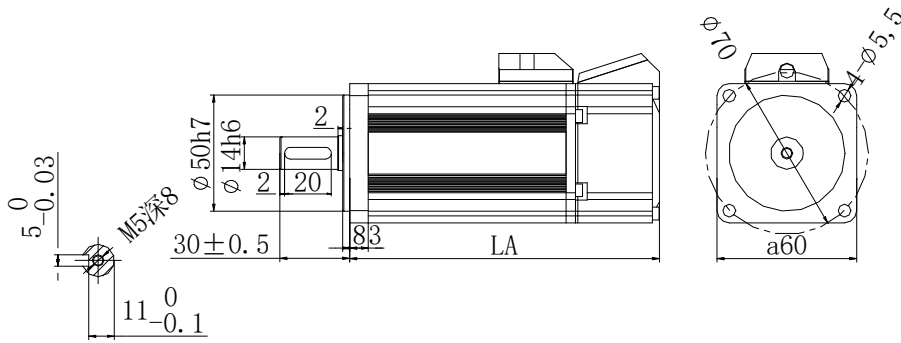

Motor model	LA±1		Inertia level	Series
	Normal	With brake		
MS5S-60ST-C□00630□□-20P2-S01/S02	79	114	Low inertia	MS5 series
MS5S-60ST-C□01330□□-20P4-S01/S02	99	134		
MS5H-60ST-C□00630□□-20P2-S01/S02	91	126	High inertia	
MS5H-60ST-C□01330□□-20P4-S01/S02	111	146		
MS-60STE-T01330-20P4-D01	145	189	-	

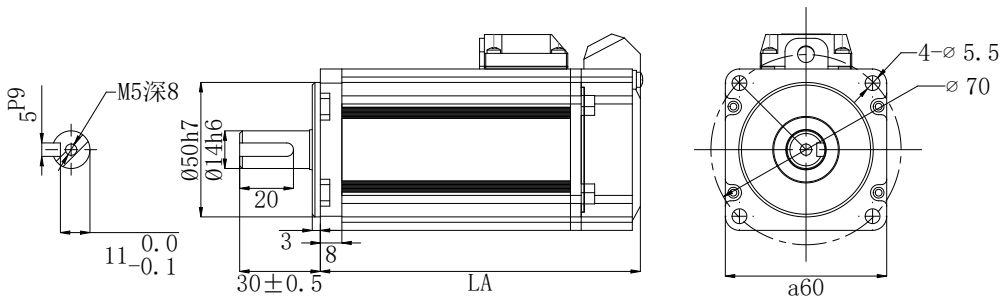

Motor model	LA±1		Inertia level
	Normal	With brake	
MS6H-60C□30B□□-20P4	119	151	High inertia
MS6S-60C□30B□□-20P4	107	139	Low inertia
MS6H-60C□30B□□-20P2	90	121	High inertia

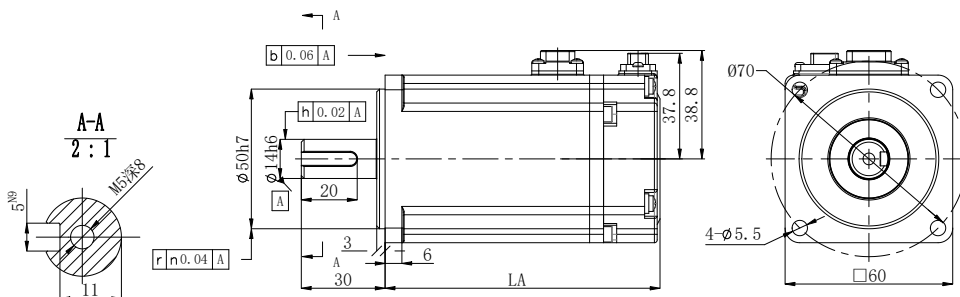

Motor model	LA±1		Inertia level
	Normal	With brake	
MS6H-60□□30B□3-20P2	76.4	99.15	High inertia
MS6S-60□□30B□3-20P4	98.4	121.15	Low inertia
MS6H-60□□30B□3-20P4	98.4	121.15	High inertia

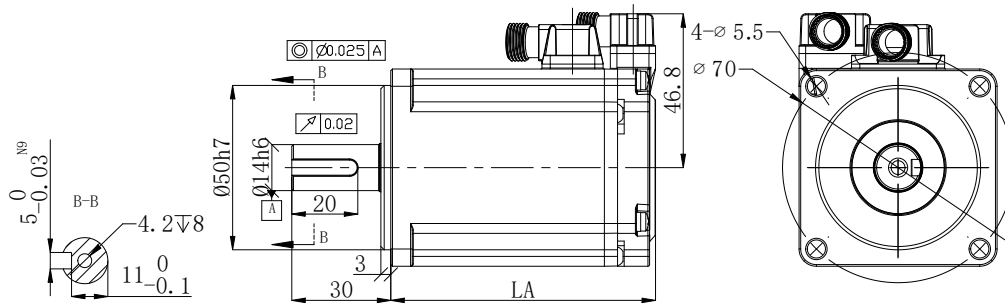

Motor model	LA±1		Inertia level
	Normal	With brake	
MS6H-60CM30B□4-20P4	80.2	106.95	High inertia

■ 80 series motor installation dimensions Unit: mm

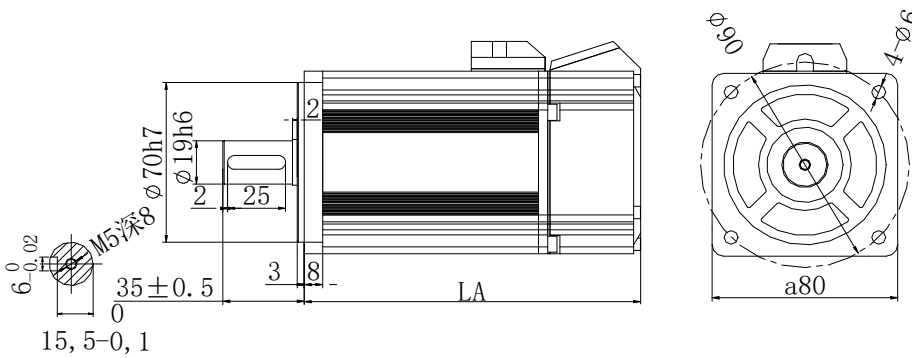

Motor model	LA±1		Inertia level
	Normal	With brake	
MS5S-80ST-C□02430□□-20P7-S01/S02	107	144	Low inertia
MS5S-80ST-C□03230□□-21P0-S01/S02	128	165	
MS5H-80ST-C□02430□□-20P7-S01/S02	119	156	High inertia
MS5H-80ST-C□03230□□-21P0-S01/S02	140	177	
MS-80ST-T02430□□-20P7	150	199	-
MS-80ST-T03520□□-20P7	179	219	

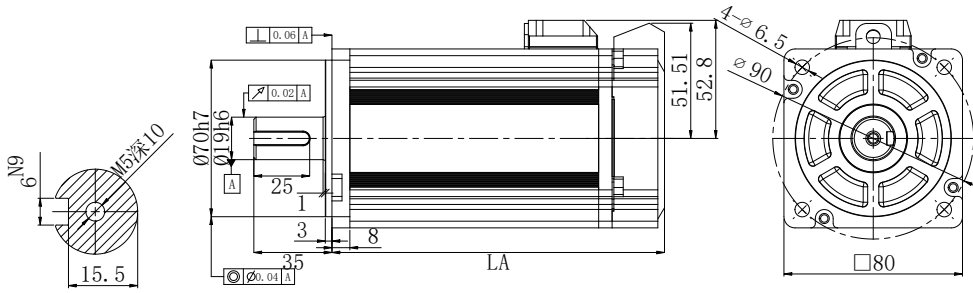

Motor model	LA±1		Inertia level
	Normal	With brake	
MS6S-80C□30B□1/2-20P7	117	150	Low inertia
MS6S-80C□20B□1/2-20P7	127	160	
MS6H-80C□30B□1/2-20P7	124	157	High inertia
MS6H-80C□20B□1/2-20P7	149	182	
MS6S-80TL30B1-20P7	117	-	Low inertia

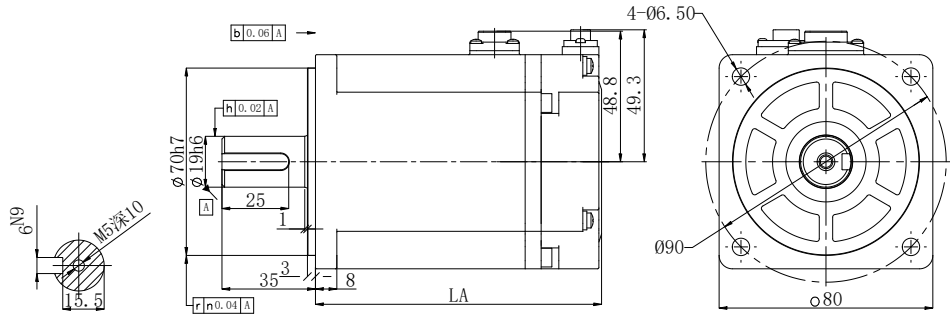

Motor model	LA±1		Inertia level
	Normal	With brake	
MS6S-80C□30B□3-20P7	107.1	132.1	Low inertia
MS6H-80C□30B□3-20P7	107.1	132.1	High inertia
MS6S-80C□30B□3-21P0	117.6	142.6	Low inertia
MS6H-80C□30B□3-21P0	134	159	High inertia

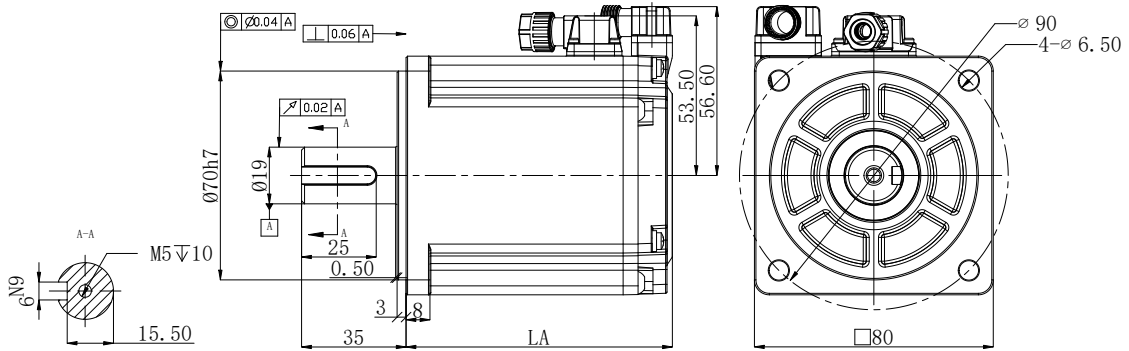

Motor model	LA±1		Inertia level
	Normal	With brake	
MS6H-80CM30B□4-20P7	89.2	121.1	High inertia

■ 100 series motor installation dimensions Unit: mm

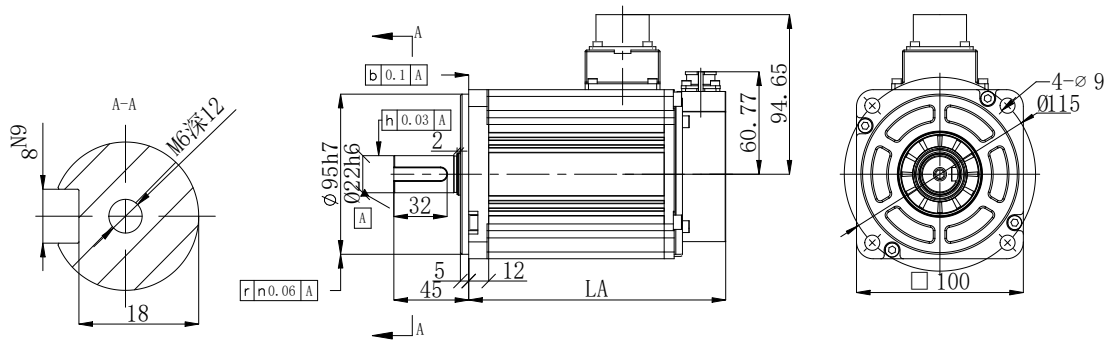

Motor model	LA±1		Inertia level
	Normal	With brake	
MS6S-100C□30B2-21P5	154.5	183	Low inertia
MS6S-100C□30B□2-21P0	138.5	164	
MS6S-100TL30B□2-21P0	144.2	169.7	

■ 110 series motor installation dimensions Unit: mm

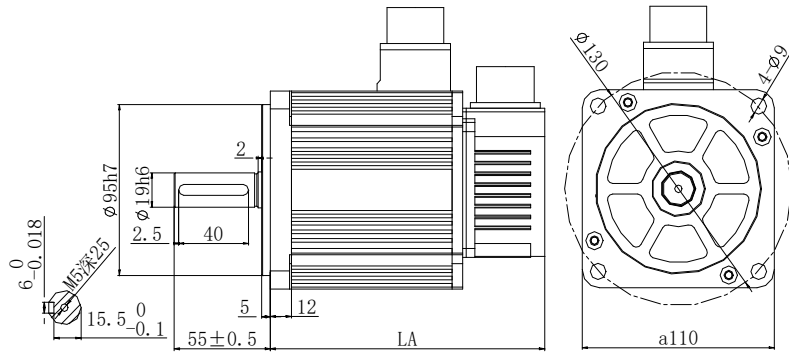

Motor model	LA±1		Inertia level
	Normal	With brake	
MS5S-110ST-C□03230B□-21P0-S01	157	205	Low inertia
MS5S-110ST-TL03230B□-21P0-S01	157	205	
MS5S-110ST-C□04830B□-21P5-S01	166	214	
MS5S-110ST-TL04830B□-21P5-S01	166	214	
MS5S-110ST-C□06030B□-21P8-S01	181	229	
MS-110ST-TL06030B□-21P8-S01	181	229	-
MS-110ST-T04030B-21P2	157	205	
MS-110ST-T05030B-21P5	166	214	

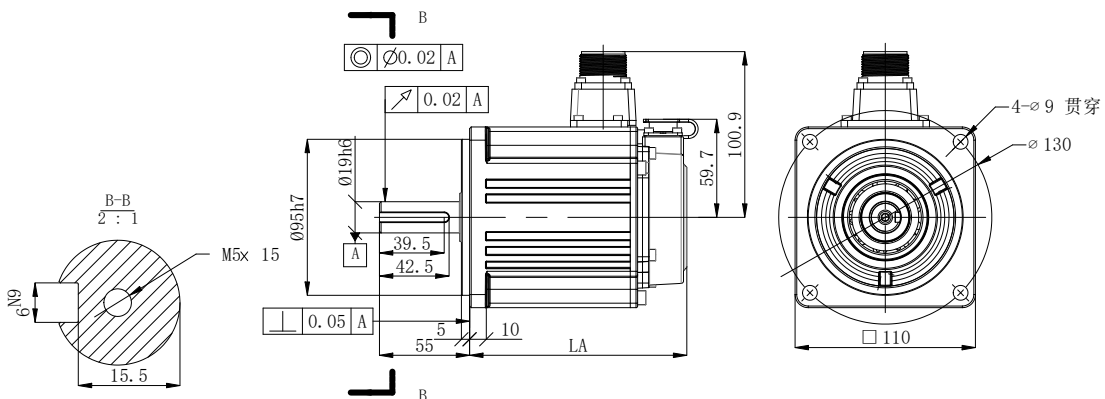

Motor model	LA±1		Inertia level
	Normal	With brake	
MS6G-110CS□30B□2-21P5	132.5	-	Medium inertia
MS6G-110TL30B2-□1P5	149	-	

■ 130 series motor installation dimensions Unit: mm

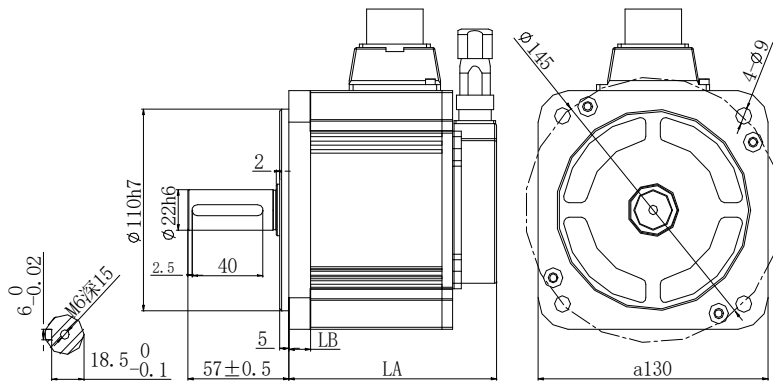

Motor model	LA±1		LB	Inertia level
	Normal	With brake		
MS5G-130STE-C□05415B□-20P8-S01	117.5	147	12.5	Medium inertia
MS5G-130STE-TL05415B□-20P8-S01	134.5	164.5		
MS5G-130STE-C□07220B□-21P5-S01	133.5	162.5		
MS5G-130STE-C□07220B□-41P5-S01	133.5	162.5		
MS5G-130STE-TL07220B□-21P5-S01	149.5	179.5		
MS5G-130STE-TL07220B□-41P5-S01	149.5	179.5		
MS5G-130STE-C□11515B□-21P8-S01	159.5	189.5		
MS5G-130STE-C□11515B□-41P8-S01	159.5	189.5		
MS5G-130STE-TL11515B□-21P8-S01	176.5	206.5		
MS5G-130STE-TL11515B□-41P8-S01	176.5	206.5		
MS5G-130STE-C□14615B□-22P3-S01	180.5	210.5		
MS5G-130STE-C□14615B□-42P3-S01	180.5	210.5		
MS5G-130STE-TL14615B□-22P3-S01	197.5	227.5		
MS5G-130STE-TL14615B□-42P3-S01	197.5	227.5		
MS5G-130STE-C□07330B□-22P4-S01	133.5	163.5		
MS5G-130STE-TL07330B□-22P4-S01	149.5	179.5		
MS5G-130STE-C□10025B□-22P6-S01	159.5	189.5		
MS-130ST-T06025B□-21P5	179	238		
MS-130ST-T10015B□-21P5	205	264		
MS-130STE-T15015G□-22P3	235	294		
MS-130STE-T07730B□-22P4	205	264		
MS-130ST-T10025B□-22P6	209	290		
MS-130ST-TL10030□□-43P0	225	284		

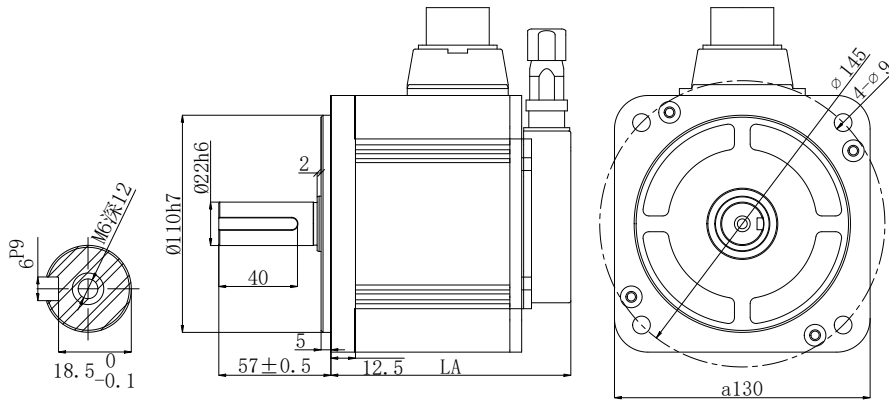

Motor model	LA±1		Inertia level
	Normal	With brake	
MS5G-130STE-C□06025B□-21P5-S01	123.5	153.5	Medium inertia
MS5G-130STE-C□10015B□-21P5-S01	146.5	176.5	

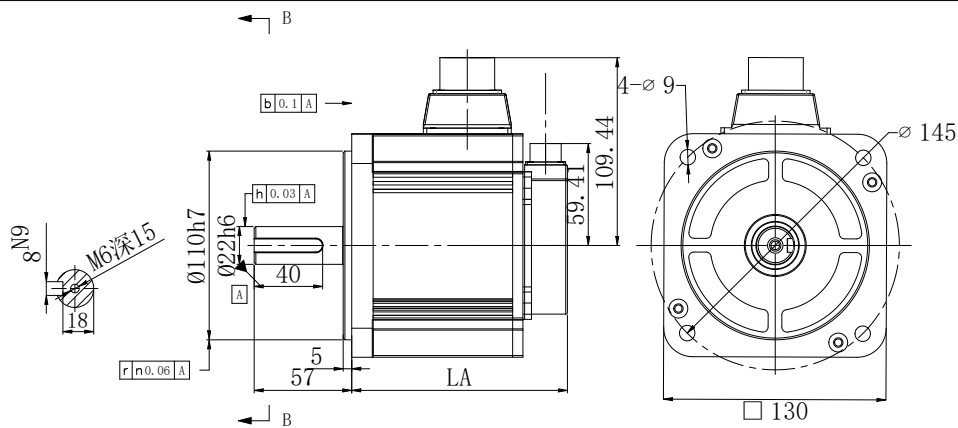

Motor model	LA±1		Inertia level
	Normal	With brake	
MS6H-130C□15B□2-20P8	126	156	High inertia
MS6H-130C□15B□2-40P8	126	156	
MS6H-130TL15B□2-20P8	142	172	
MS6H-130TL15B□2-40P8	142	172	
MS6H-130C□15B□2-41P3	148	178	
MS6H-130TL15B□2-41P3	164	194	
MS6H-130C□20B□2-21P5	148	178	
MS6H-130TL20B□2-21P5	164	194	
MS6H-130C□15B□2-21P8	175	205	
MS6H-130C□15B□2-41P8	175	205	
MS6H-130TL15B□2-21P8	191	221	
MS6H-130TL15B□2-41P8	191	221	
MS6H-130C□15B□2-22P3	195.6	225.6	
MS6H-130C□15B□2-42P3	195.6	225.6	
MS6H-130TL15B□2-22P3	211.6	241.6	
MS6H-130TL15B□2-42P3	211.6	241.6	

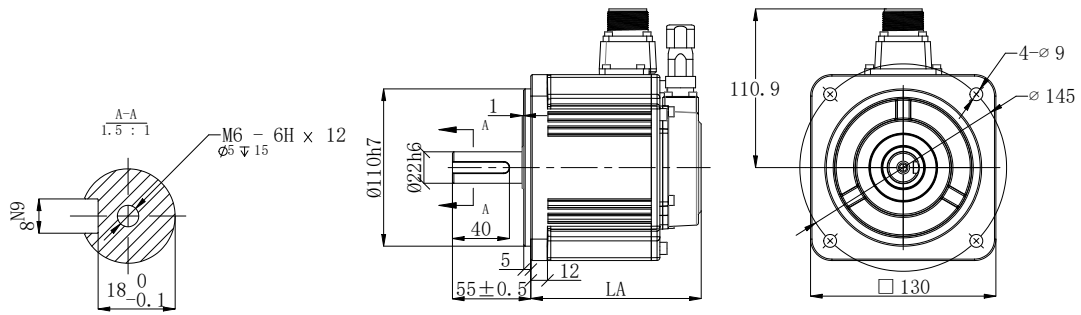

Motor model	LA±1		Inertia level
	Normal	With brake	
MS6G-130C□25B□2-□1P0	119.5	148.5	Medium inertia
MS6G-130TL25B□2-□1P0	136	165	
MS6G-130C□20B□2-□1P5	133.5	162.5	
MS6G-130TL20B□2-□1P5	150	179	
MS6G-130C□15B□2-□1P5	151.5	180.5	
MS6G-130TL15B□2-□1P5	168	197	
MS6G-130C□15E□2-□2P3	181.5	210.5	
MS6G-130TL15E□2-□2P3	198	227	

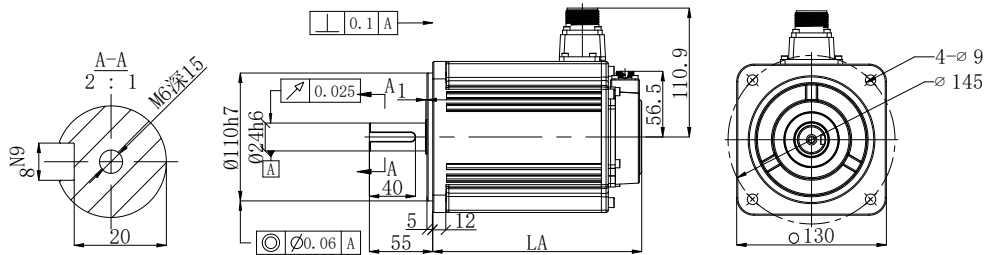

Motor model	LA±1		Inertia level
	Normal	With brake	
MS6G-130C□15B□2-□2P3	181.5	210.5	Medium inertia
MS6G-130TL15B□2-□2P3	198	227	Medium inertia

■ 180 series motor installation dimensions Unit: mm

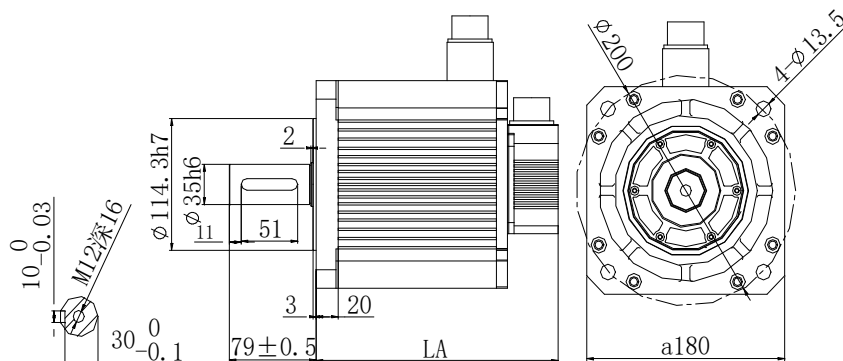

Motor model	LA±1		Inertia level
	Normal	With brake	
MS5G-180ST-TL19015□□-42P9-S01	221	303	Medium inertia
MS5G-180ST-TL28015□□-44P4-S01	247	329	

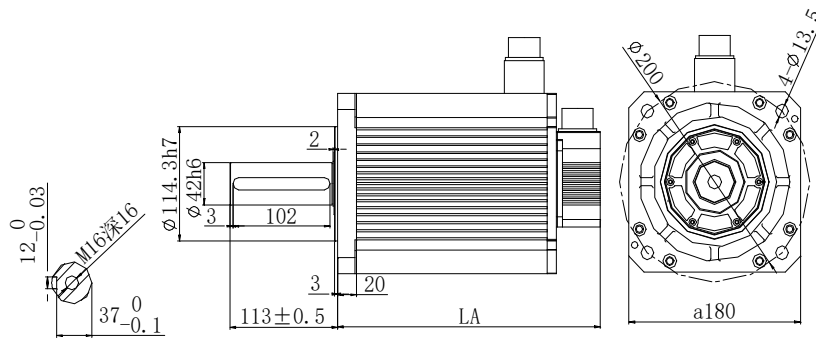

Motor model	LA±1		Inertia level
	Normal	With brake	
MS5G-180ST-TL35015□-45P5-S01	277	359	Medium inertia
MS5G-180ST-TL48015□-47P5-S01	308	390	

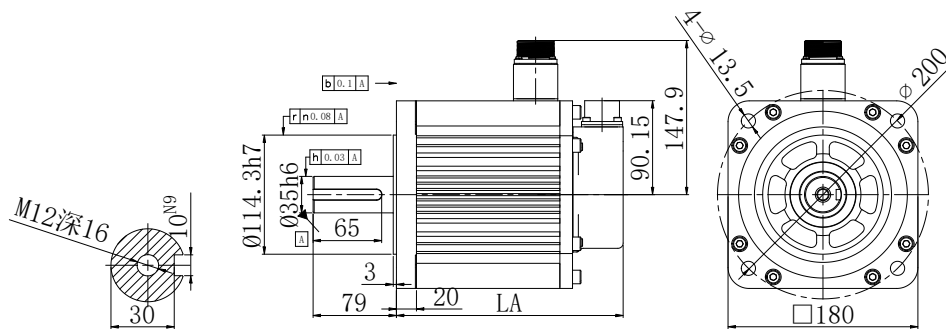

Motor model	LA±1		Inertia level
	Normal	With brake	
MS6H-180C□15B□2-43P0	215	255	High inertia
MS6H-180TL15B□2-43P0	215	255	
MS6H-180C□15B□2-44P4	247	287	
MS6H-180TL15B□2-44P4	247	287	

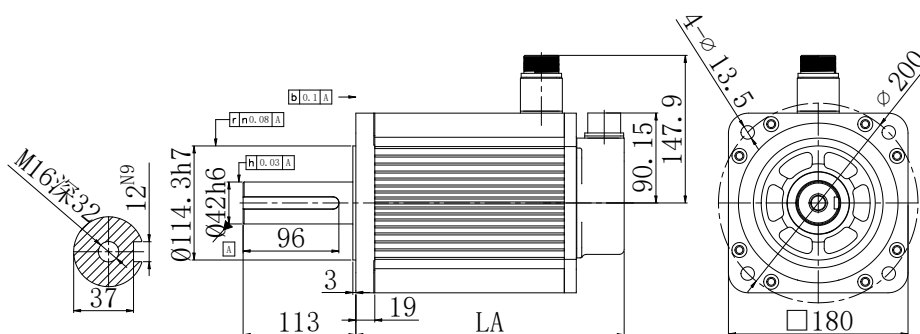

Motor model	LA±1		Inertia level
	Normal	With brake	
MS6H-180C□15B□2-45P5	269	309	High inertia
MS6H-180TL15B□2-45P5	269	309	
MS6H-180C□15B□2-47P5	325	365	
MS6H-180TL15B□2-47P5	325	365	

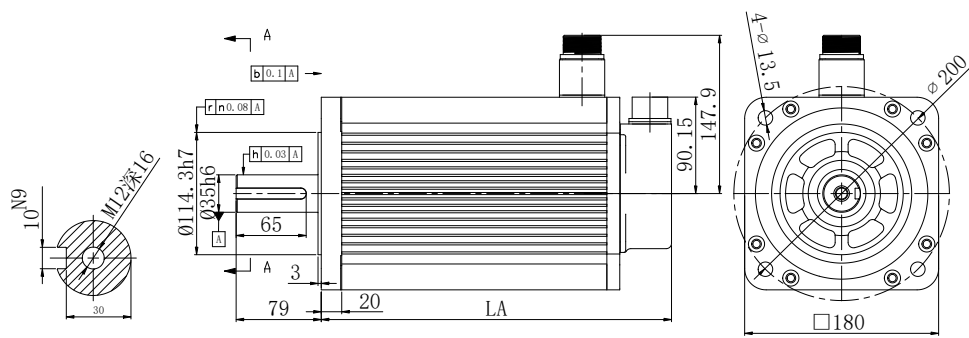

Motor model	LA±1		Inertia level
	Normal	With brake	
MS6H-180CS/CM15E□2-45P5	269	309	High inertia
MS6H-180CS/CM15E□2-47P5	325	365	

■ 220 series motor installation dimensions Unit: mm

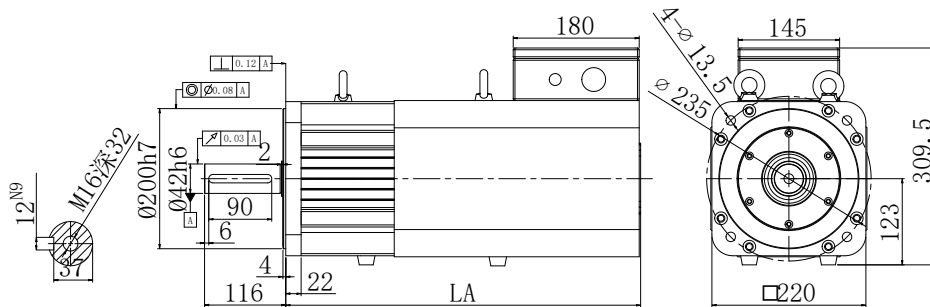

Motor model	LA±1		Inertia level
	Normal	With brake	
MS-220STE-TL70015B□-411P0-XJ	454	549	-
MS-220STE-TL96015B□-415P0-XJ	507	602	

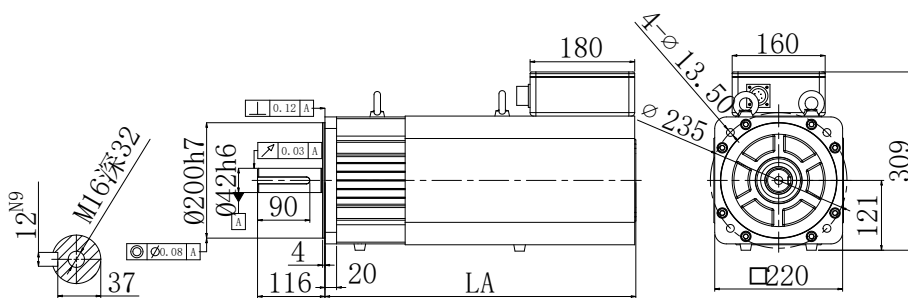

Motor model	LA±1		Inertia level
	Normal	With brake	
MS5G-220STE-□□40015B-422P0-S01	535	-	Medium inertia

3 Servo system wiring

3.1 Servo driver terminal wire specification

The recommended wiring for each interface of the servo drive is shown in the table below:

Driver model	Power supply wire-diameter mm ²	UVW power cable-diameter mm ²	Encoder cable-diameter mm ²	Ground cable  -diameter mm ²
DS5C1-20P1/20P2/20P4/20P7-PTA	0.75	0.75	0.2	0.75
DS5C1-21P0/21P5/22P3/22P6/41P0/41P5/43P0-PTA	2.0	2.0	0.2	2.0
DS5C1-45P5-PTA	6.0	6.0	0.2	6.0
DS5C1-47P5-PTA	6.0	6.0	0.2	6.0
DS5C1-411P0-PTA	6.0	6.0	0.2	6.0
DS5C1-415P0-PTA	6.0	6.0	0.2	6.0
DS5C1-422P0-PTA	10.0	10.0	0.2	6.0
DS5C1-432P0-PTA	12.0	12.0	0.2	4.0
DS5C1-445P0-PTA	30.0	30.0	0.2	16.0



- Please do not pass the power cable and signal cable through the same pipeline, and do not tie them together. When wiring, please keep the power cable and signal cable at least 30cm apart.
 - For signal cables and encoder (PG) feedback cables, please use multi stranded wires and multi-core twisted overall shielded wires.
 - For the wiring length, the maximum length of the instruction input cable is 3m, and the maximum length of the PG feedback cable is 20m.
 - Even if the power supply to the driver is disconnected and the panel displays OFF, the internal capacitance of the servo unit will still be stuck with high voltage. Please do not touch the power terminal temporarily (within 10 minutes).
 - Do not frequently turn on or off the power supply of the driver. When it is necessary to repeatedly switch on and off the power supply continuously, it is necessary to ensure that the power switch frequency is greater than 2 minutes per time. The servo drive has a large capacitor inside, so when the power is turned on, the internal circuit of the drive will flow a large charging current (charging time of 0.2 seconds). Therefore, if the power supply is frequently switched on and off, it will cause a decrease in the performance of the main circuit components inside the servo drive, affecting the service life of the drive.
-

3.2 Main circuit terminal

■ DS5C1-20P1/P2/P4-PTA

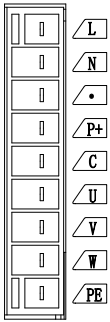

Terminal	Function	Explanation
L/N	Main circuit power input terminal	Single phase AC200 ~ 240V, 50/60Hz
●	Vacant terminal	-
P+, C	Use external regenerative resistor	Connect regenerative resistor between P+ and C, P0-25=power value, P0-26=resistor value
U, V, W, PE	Motor connection terminal	Connect the motor

■ DS5C1-20P7-PTA

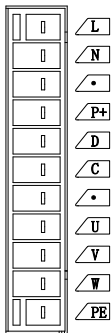

Terminal	Function	Explanation
L/N	Main circuit power input terminal	Single phase AC200~240V, 50/60Hz
●	Vacant terminal	-
P+, D, C	Use internal regenerative resistor	Short P+ and D, disconnect P+ and C
	Use external regenerative resistor	Connect regenerative resistor between P+ and C, disconnect P+ and D, P0-25= power value, P0-26= resistor value
●	Vacant terminal	-
U, V, W, PE	Motor connection terminal	Connect the motor

■ DS5C1-21P0/21P5/22P3/22P6-PTA

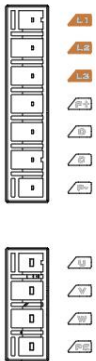

Terminal	Function	Explanation
L1/L2/L3	Main circuit power input terminal	Single phase AC200~240V, 50/60Hz
P+, D, C	Use internal regenerative resistor	Short P+ and D, disconnect P+ and C
	Use external regenerative resistor	Connect regenerative resistor between P+ and C, disconnect P+ and D, P0-25= power value, P0-26= resistor value
P+, P-	Bus terminal	Can measure real-time bus voltage. Please pay attention to the danger.
U, V, W	Motor terminals	Connected with motor Note: the ground wire is on the radiator, please check it before power on
⊕	Ground terminal	Connect to ground terminal of motor, then connect to the ground

■ DS5C1-41P0/41P5/42P3/43P0-PTA

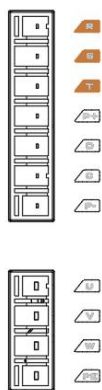

Terminal	Function	Explanation
R, S, T	Main circuit power input terminal	3-phase AC380~440V, 50/60Hz
P+, D, C	Use internal regenerative resistor	Short P+ and D, disconnect P+ and C
	Use external regenerative resistor	Connect regenerative resistor between P+ and C, disconnect P+ and D, P0-25= power value, P0-26= resistor value
P+, P-	Bus terminal	Can measure real-time bus voltage. Please pay attention to the danger.
U, V, W	Motor terminals	Connected with motor Note: the ground wire is on the radiator, please check it before power on
⊕	Ground terminal	Connect to ground terminal of motor, then connect to the ground

■ DS5C1-45P5/47P5-PTA

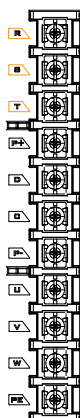

Terminal	Function	Description
R, S, T	Main circuit power input terminal	3-phase AC380~440V, 50/60Hz
P+, D, C	Use internal regenerative resistor	Short P+ and D, disconnect P+ and C (This model does not have a built-in braking resistor and is not supported)
	Use external regenerative resistor	Connect regenerative resistor between P+ and C, P0-25= power value, P0-26= resistor value
P+, P-	Bus terminal	Can measure real-time bus voltage. Please pay attention to the danger.
U, V, W, PE	Motor terminals	Connected with motor Note: the ground wire is on the radiator, please check it before power on
⊕	Ground terminal	Connect to ground terminal of motor, then connect to the ground

■ DS5C1-411P0/415P0/422P0/432P0/445P0-PTA

Terminal	Function	Description
R, S, T	Main circuit power input terminal	3-phase AC380~440V, 50/60Hz
●	Empty terminal	-
U, V, W	Motor terminals	Connected with motor Note: the ground wire is on the radiator, please check it before power on
P+, PB	Use external regenerative resistor	Connect regenerative resistor between P+ and PB, P0-25= power value, P0-26= resistor value
P+, P-	Bus terminal	Can measure real-time bus voltage. Please pay attention to the danger.

3.3 Interface terminal

3.3.1 CN0, CN1, CN2, CN3 terminal description

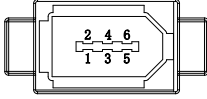
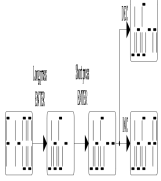
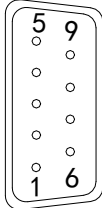
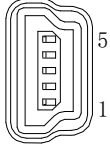
Power	CN0		CN1	CN2	CN3
	750W and below	Above 750W			
7.5kW and below	SI1 SI2 SI3 +24V	S01 S02 S03 COM	SI1 SI2 SI3 SI4 SI5		
11kW and up					

3.3.2 CN0 control terminal

■ CN0 terminal explanation(below 750W, 3 in/3 out)

No.	Name	Note	No.	Name	Note
1	SI1	Input terminal 1(high speed)	5	SO1	Output terminal 1
2	SI2	Input terminal 2(high speed)	6	SO2	Output terminal 2
3	SI3	Input terminal 3	7	SO3	Output terminal 3
4	D+24V	Open collector input	8	COM	Output terminal (ground)

■ CN0 terminal explanation(1~ 7.5kW, 5 in/3 out)

No.	Name	Note	No.	Name	Note
1	SI1	Input terminal 1	6	+24V	Open collector access
2	SI2	Input terminal 2	7	SO1	Output terminal 1
3	SI3	Input terminal 3	8	SO2	Output terminal 2
4	SI4	Input terminal 4 (high speed)	9	SO3	Output terminal 3
5	SI5	Input terminal 5 (high speed)	10	COM	Output terminal (ground)

■ CN0 terminal explanation(11kW, 5 in/4 out)

No.	Name	Note	No.	Name	Note
1	P-	Pulse -	11	+24V	Input common terminal
2	P+5	Pulse +5v	12	SI1	Input terminal
3	P+24	Pulse +24v	13	SI2	Input terminal
4	D-	Direction -	14	SI3	Input terminal
5	D+5	Direction +5v	15	SI4	Input terminal (high speed)
6	D+24	Direction +24v	16	SI5	Input terminal (high speed)
7	SO1+	Output terminal +	17	SO1-	Output terminal -
8	SO2+	Output terminal +	18	SO2-	Output terminal -
9	SO3+	Output terminal +	19	SO3-	Output terminal -

No.	Name	Note	No.	Name	Note
10	SO4+	Output terminal +	20	SO4-	Output terminal -

3.3.3 CN1 communication terminal description

100~750W, 11kW and up	1kW~7.5kW	No.	Name	No.	Name
		1	TX A+	9	TX B+
		2	TX A-	10	TX B-
		3	RX A+	11	RX B+
		4	-	12	-
		5	-	13	-
		6	RX A-	14	RX B-
		7	-	15	-
		8	-	16	-

3.3.4 CN2 encoder interface description

■ 7.5kW and below

The arrangement of the encoder socket terminals on the side of the CN2 driver body is as follows:

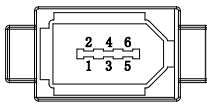

No.	Definition
1	5V
2	GND
5	A
6	B

■ 11kW and up

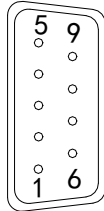

No.	Definition	No.	Definition
1	Temperature -	6	GND
2	Temperature +	7	GND
3	485-B	8	5V
4	485-A	9	5V
5	PE		

3.3.5 CN3 terminal (RS232)

■ CN3 (RS-232 communication)

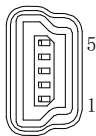

Driver side-5-pin trapezoidal interface

No.	Name	Note
1	TXD	RS232 send
2	RXD	RS232 receive
3	GND	RS232 signal ground

Note: Please use the dedicated cable provided by XINJE company.

RS232 communication is full duplex communication, and the TXD (pin number 1) of the driver 232 communication port needs to be connected to the RX pin of USB to serial convertor. The RXD (pin number 2) of the port needs to be connected to the TX pin of USB to serial convertor.

RS232 port default communication parameters: baud rate 19200bps, data bit is 8-bit, stop bit is 1-bit, even parity. Suggest to use 115200 communication speed, internal hardware supports up to 250kHz, supports hot swapping.

Modbus station No.

Parameter	Function	Default setting	Range	Modify	Effective
P7-10	Modbus station no.	1	1~255	Servo OFF	At once

3.4 Signal terminal

3.4.1 Pulse signal (11kw and up models supported)

Instruction form	Option	Meaning	P-input signal	D-input signal	Chapter
P0-10 xxx□	1	AB phase mode	A phase	B phase	5.3.2.2
	2	Pulse+direction mode	pulse	direction	
Collector open circuit type (24V voltage) input signal is P+ (pin 3)/D+ (pin 6)					
Differential mode (5V voltage) input signal is P+ (pin 2)/D+ (pin 5)					

The interface circuit for the open collector/differential signal pulse input is shown in the wiring diagram below:

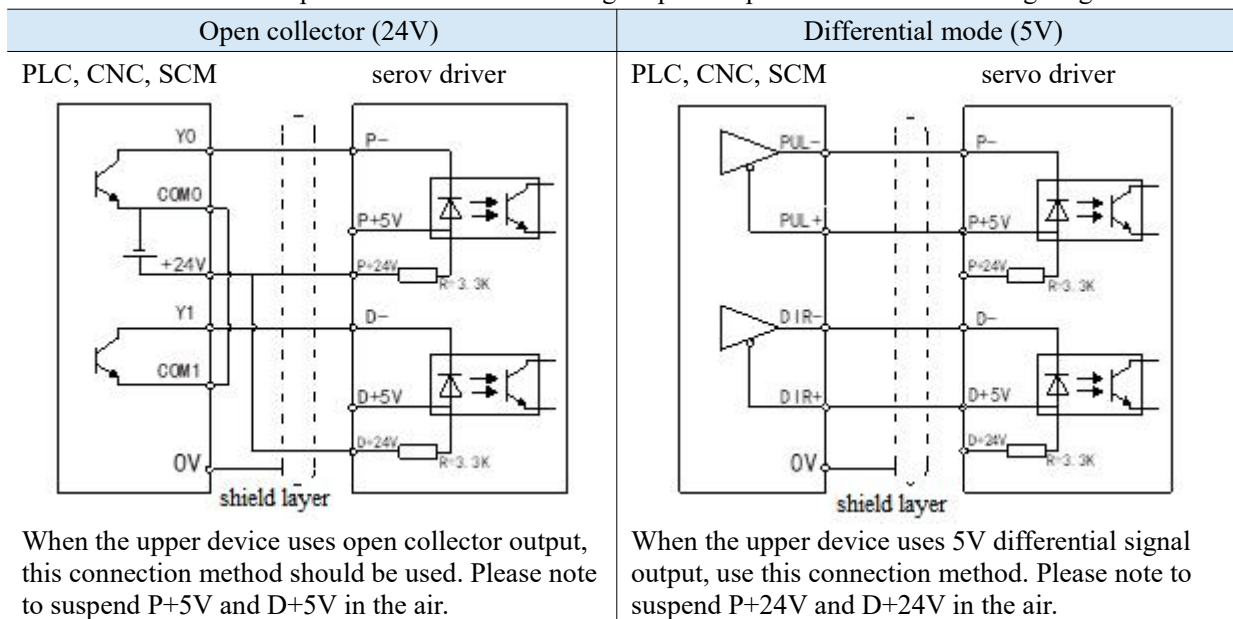

■ Pulse input specification

Pulse specification		Max input frequency	Voltage specification
P- P+5V D- D+5V	5V differential input	500kHz	Typical 5V (3.3V~5V)
P-P+24V D-D+24V	24V OC input	200kHz	Typical DC24V (18V~28V)



- To improve anti-interference, please make sure to use twisted pair shielded wires, and it is recommended to use command signal wires within 3 meters. It is recommended to shield the 0V of the controller and ensure good grounding of the servo;
- P-/P+24V, D-/D+24V power supply voltage range 18V~25V. The power supply voltage range of P-/P+5V and D-/D+5V is 3.3V~5V. If it is lower than 18V/3.3V, there will be pulse and direction abnormalities;
- Servo pulse input port 10mA conduction;
- If the controller is a Xinje PLC, the rated current of the pulse output port is 50mA. Based on this data, it is determined that theoretically, one pulse can carry up to 5 servos. Suggest a maximum of 3.

3.4.2 SI input signal

Please use a relay or an open collector transistor circuit to connect. When using relay connection, please select the relay for small current. If the relay is not small current, it will cause bad contact.

Type	Input terminal	Function
Digital input	SI1~SI5	Multifunctional input signal terminal

Defaulted assignment of input terminals

Terminal	SI1	SI2	SI3	SI4	SI5
Function	P-OT/forward run prohibition	N-OT/reverse run prohibition	Home signal	Not distributed	Not distributed

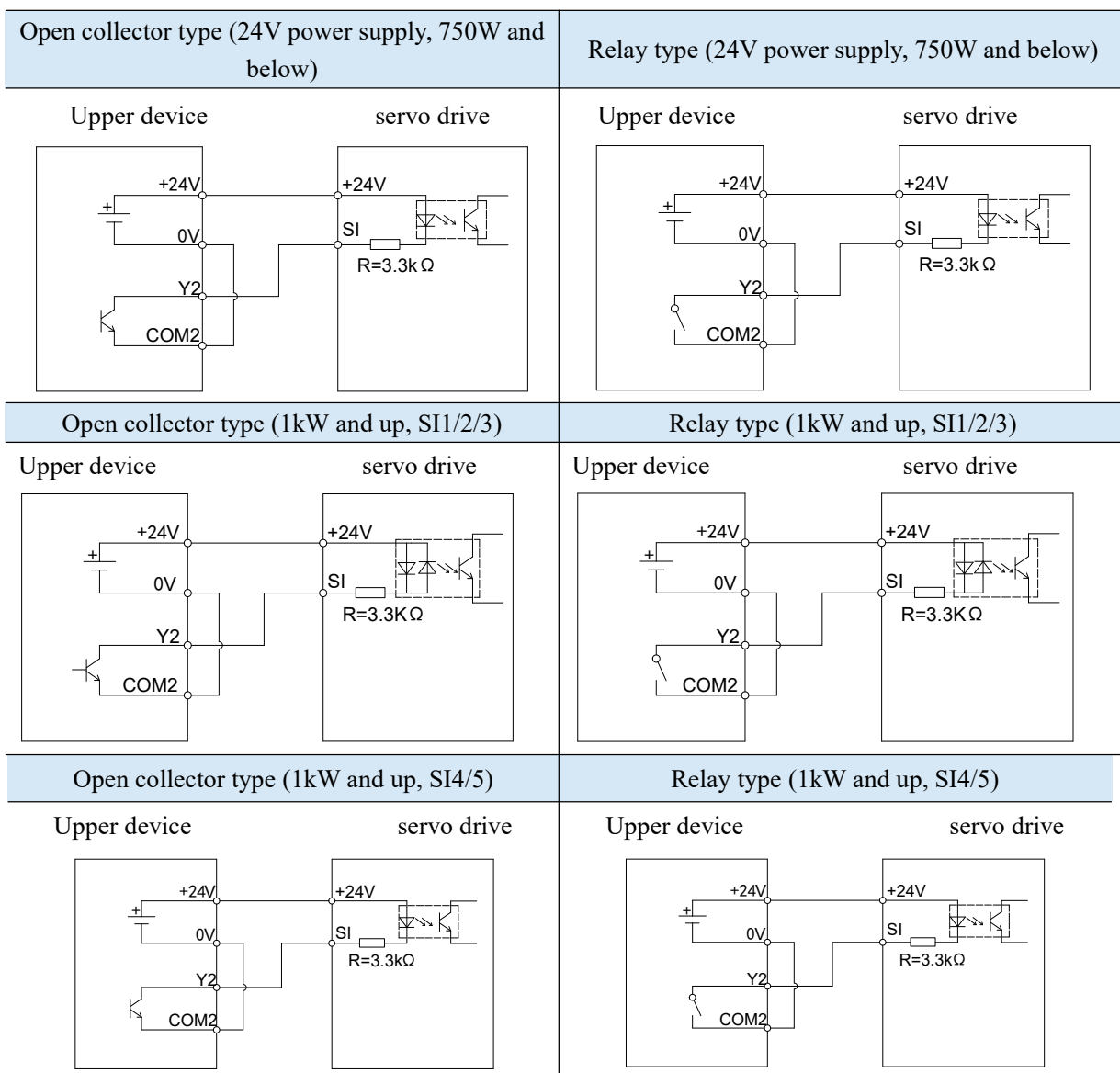



- SI1 and SI2 of 750W and below drivers are high-speed SI inputs, SI3 is low-speed, and only supports NPN connection;
- SI1, SI2, and SI3 are low-speed SI inputs for 1kW and above servo drivers, with a response time of less than or equal to 2ms, supporting NPN and PNP connections; SI4 and SI5 are high-speed SI inputs with a response speed of less than or equal to 2μs. Only supports NPN connection;
- Typical voltage DC24V, minimum not lower than DC18V, maximum allowable voltage not higher than DC28V.

3.4.3 SO output signal

Type	Output terminal	Function
Optocoupler output	SO1~SO4	Multifunctional output terminal

Defaulted assignment of output terminals

Terminal	SO1	SO2	SO3~SO4
Function	COIN/positioning completion	ALM/alarm	Not distribute

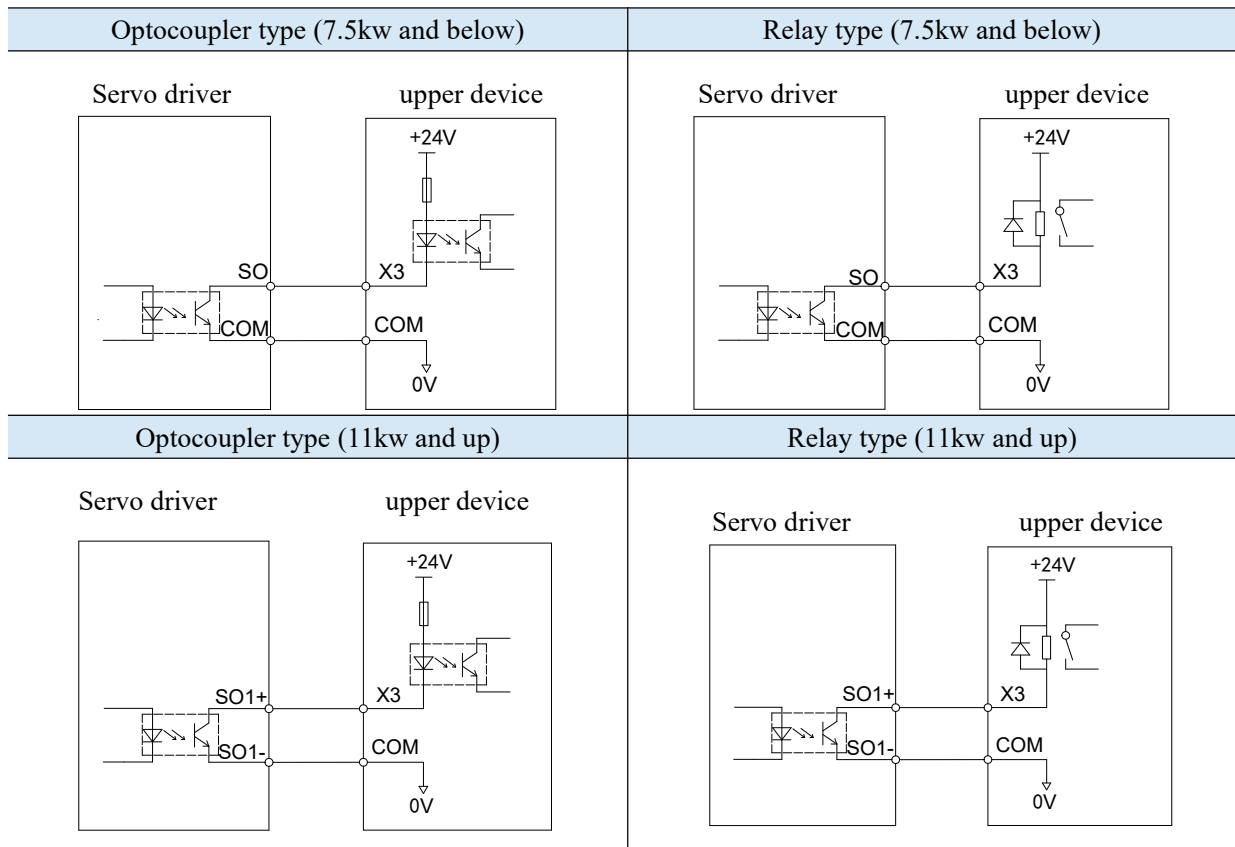



- SO1, SO2, and SO3 for 7.5kW and below servo drivers only support NPN connection;
- SO1, SO2, SO3, and SO4 for 11 kW and above drivers are marked with + and -, and SO1-, SO2-, SO3-, and SO4- can be connected together when using a common COM;
- Maximum load current:
400W and below: SO1 DC 500mA (maximum), SO (other) DC 50mA (maximum);
750W and above: SO (all) DC 50mA (maximum), supporting 24VDC, maximum not exceeding 30VDC, controlling the holding brake motor through SO, please use intermediate relay.

3.5 EtherCAT communication connection

The wiring of EtherCAT motion control system is very simple. Thanks to EtherCAT, the star topology of Ethernet can be replaced by a simple linear structure. Taking Xinje DS5C1 series servo as an example, because EtherCAT does not need hub and switch, and DS5C1 series servo is equipped with EtherCAT communication network port, the consumption of cable and bridge is greatly reduced, the workload of connection design and joint calibration is also greatly reduced, which is convenient for saving installation cost.

Linear connection is recommended for EtherCAT bus connection. The wiring mode is as follows:

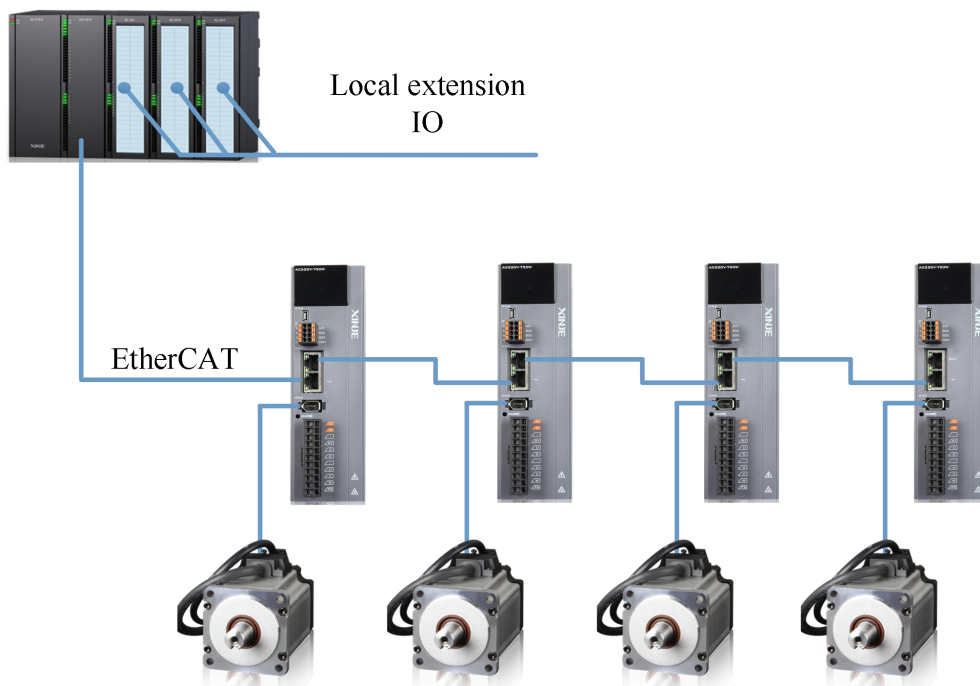

Note: The two communication network ports of the servo driver follow the principle of "down in and up out", that is, the master station must be connected with the network port below LAN1 port of the first servo, and then the above network port of the first servo is connected with the below network port of the second servo, and so on. The number of nodes connected to the network depends on the performance of the master station. Please consider the maximum number of nodes supported by the master station when selecting the model.

In the process of communication transmission, it will inevitably be affected by the surrounding electromagnetic environment. It is recommended that the user use the industrial CAT5 network cable, which can also be purchased in our company.

4 Operation test and panel operation

4.1 New machine commissioning steps

The commissioning sequence of the new machine is shown in the flow chart below:

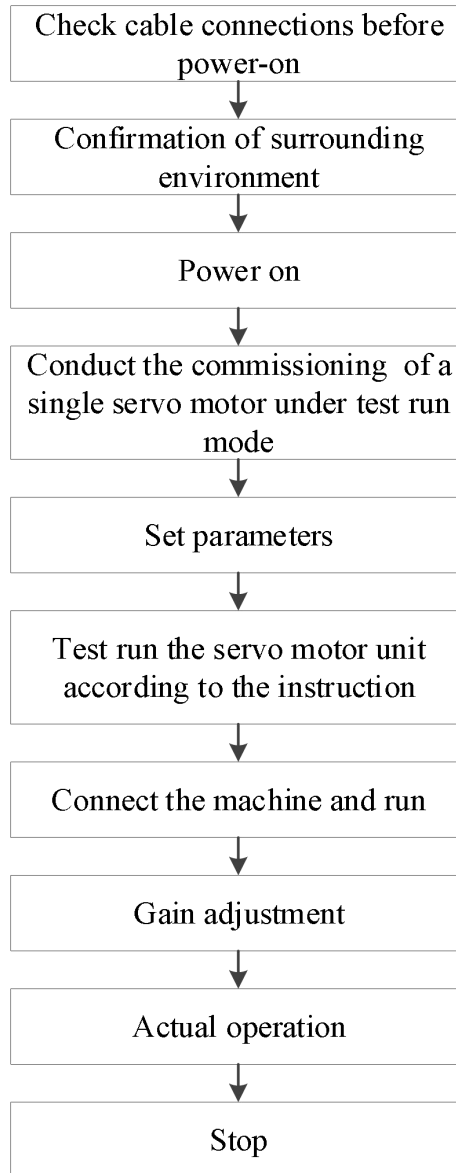

4.1.1 Wiring inspection before power on & confirmation of surrounding environment

1. Confirm whether the power cable , encoder cable and motor cable of servo driver and servo motor are connected normally, and whether there is short circuit in the power supply part. No excessive external force is applied to the cable part, and the bending degree is within the acceptable range.
2. Whether the motor is installed correctly.
3. Whether the motor and mechanical parts are displaced.
4. There are no foreign matters in the site environment such as metal chips that may cause short circuit of signal line and power line .

4.1.2 Power supply

Confirm whether the servo power supply voltage is within the specified voltage range:

The specified voltage range of 220V is 200V ~ 240V.

The specified voltage range of 380V is 380V ~ 440V.

4.1.3 Test run with idle shaft

When the servo motor is separated from the machine, try to use the test run mode at low speed to confirm whether the servo motor rotates correctly. Open loop and closed loop jogging can be realized through the panel speed mode, or jogging can be realized through the servo upper computer software XinjeServo tuner.

■ Jog by panel

The following can only take effect when the servo is not enabled (i.e. the panel is bb). Conduct the test run through the panel F1-01.

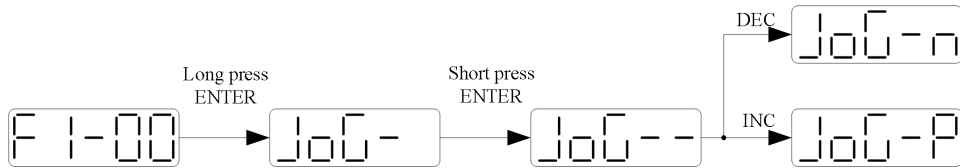
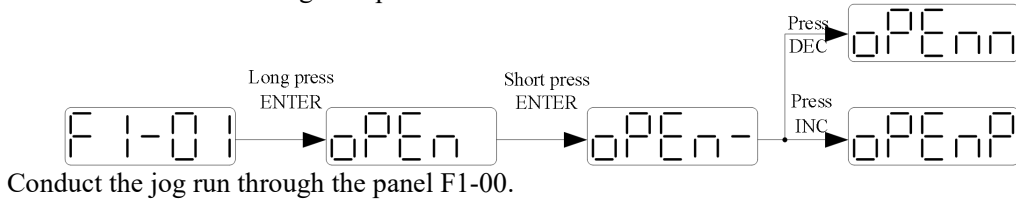

In the enabled state, Press INC for forward inching and DEC for reverse inching. Press STATUS / ESC to end the enabling and exit the inching state.

STATUS	DISPLAY	STATUS	DISPLAY
IDLE		FORWARD	
ENABLE		REVERSE	

Related parameter

Parameter	Meaning	Default setting	Unit	Range	Modify	Take effect
P3-18	JOG speed	100	1rpm	0~1000	Servo bb	At once

P3-18 is the speed configured for closed-loop inching operation. It is only effective in two inching modes, and the other normal control modes are invalid.

■ Jog operation through XinjeServo Tuner software

Open XinjeServo Tuner, set the jog speed P3-18, select [Jog run] and click [ON/OFF], then click buttons to forward run and reverse run.



Click [test run] in the menu bar, and the following screen will pop up:

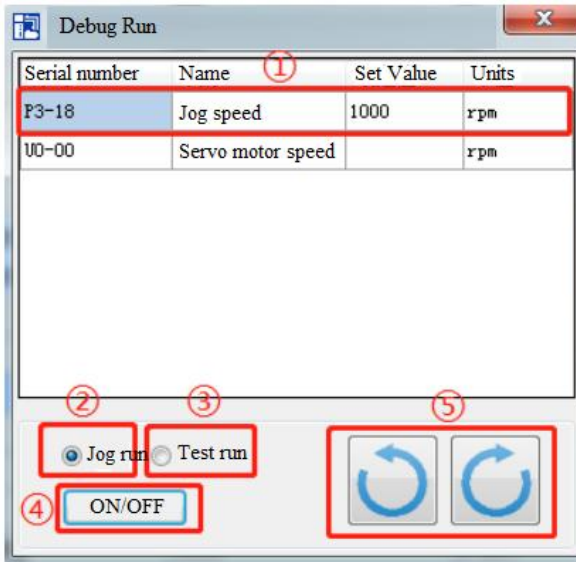

The screen is mainly divided into 5 setting modules.

① Jog speed P3-18: Set the motor speed in jog mode

② Jog run: Closed loop inching operation

③ Test run: Open loop inching operation

④ ON/OFF: Enable in the jog mode.

⑤  Forward run and reverse run.

4.1.4 Confirm the direction of motor rotation

If the servo motor is running in the opposite direction to the actual need, turn the servo OFF, then set the parameter P0-05 to 0 or 1, and then power on again for the change to take effect.

The user can change the rotation direction of servo motor through parameter P0-05. It is specified that the "forward rotation" of the motor is "counter clockwise rotation" and "reverse rotation" is "clockwise rotation". (all view from the motor axis)

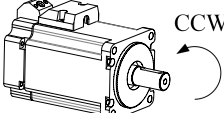
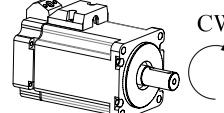
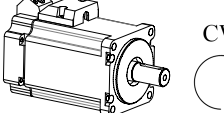
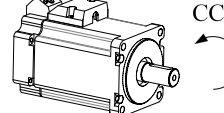
Mode	Forward running	Reverse running	P0-05 setting
Standard setting CCW is forward run			P0-05=0
Reverse mode CW is reverse run			P0-05=1

Related parameters

Parameter	Meaning	Default setting	Unit	Range	Modify	Effective
P0-05	Definition of rotation direction 0-positive mode 1-negative mode	0	-	0~1	Servo bb	Power on again

4.2 Operating panel and status description

4.2.1 Operating panel description

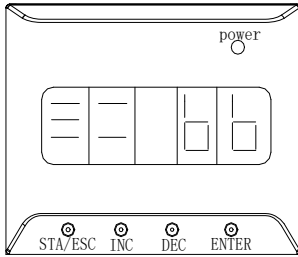

Button	Operation
STA/ESC	Short press: state switch, state return
INC	Short Press: The display data increases Long press: The display data increases continuously
DEC	Short Press: The display data decreases Long press: The display data decreases continuously
ENTER	Short press: shift. Long press: Set and view parameters.

Note: The panel will be self-checked, and all the display digital tubes and five decimal points will be lit for one second at the same time.

4.2.2 Operation display

By switching the basic state of the panel operator, it can display the running state, set parameters, run auxiliary functions and alarm state. After pressing the STA/ESC key, the states are switched in the order shown in the following figure.

State: BB indicates that the servo system is idle; run indicates that the servo system is running; RST indicates that the servo system needs to be re-energized.

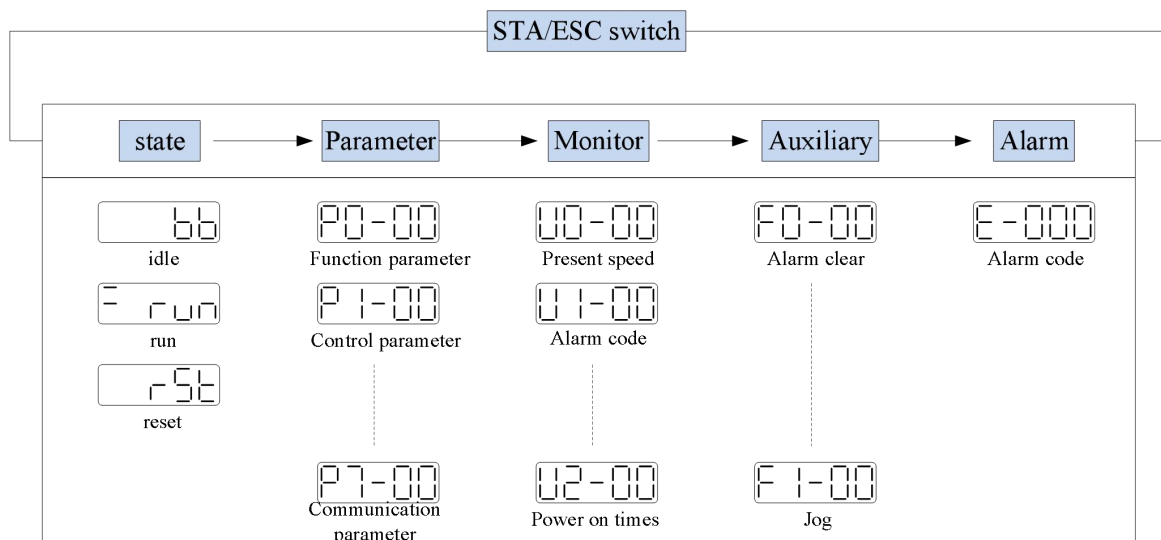

- ◆ Parametric setting PX-XX: The first X represents the group number, and the last two X represents the parameter serial number under the group.
- ◆ Monitor status UX-XX: The first X represents the group number, and the last two X represents the parameter number under the group.
- ◆ Auxiliary function FX-XX: The first X represents the group number, and the last two X represents the parameter number under the group.
- ◆ Alarm state E-XX□: The first two X represents the alarm category, and the last □ represents the small category under the category.



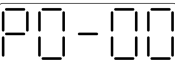
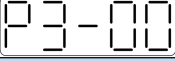
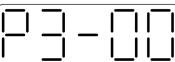
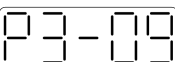
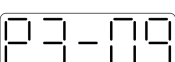
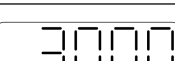

■ Parameter setting example

The following uses P3-09 as an example:

Step	Panel display	Used buttons	Operations
1		STA/ESC INC DEC ENTER ⊙ ⊙ ⊙ ⊙	No operation
2		STA/ESC INC DEC ENTER ⊙ ⊙ ⊙ ⊙	Press STA/ESC
3		STA/ESC INC DEC ENTER ⊙ ⊙ ⊙ ⊙	Press INC for three times to show P3-00
Step	Panel display	Used buttons	Operations
4		STA/ESC INC DEC ENTER ⊙ ⊙ ⊙ ⊙	Short press enter, the last 0 will flash
5		STA/ESC INC DEC ENTER ⊙ ⊙ ⊙ ⊙	Press INC for 9 times
6		STA/ESC INC DEC ENTER ⊙ ⊙ ⊙ ⊙	Long press ENTER to show the value of P3-09
7		STA/ESC INC DEC ENTER ⊙ ⊙ ⊙ ⊙	Press INC, DEC, ENTER to increase, decrease or shift, after changing, long press ENTER to confirm
8	End		

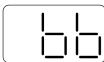
Note: When the setting parameter exceeds the range that can be set, the driver will not accept the setting value, and the driver will report E-021 (parameter setting exceeds the limit). The parameter setting overrange usually occurs when the upper computer writes parameters to the driver through communication.

4.2.3 Operating panel status description

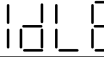
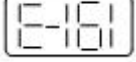
Short code display content	Display contents
	Standby status Servo OFF status (The motor is in a non-electrified state)
	In operation Servo enabling state (The motor is on-line)
	Need reset status Servo needs to be re-energized
	Forbidden forward drive state P-OT ON status.
	Forbidden reversal drive state N-OT ON status.
	Control mode 2 is vacant.
	The panel is in the alarm state, and the alarm needs to be cleared first. Please refer to Section 10.2 for specific alarm information.

4.2.4 Operation state display

When powered on, the panel displays, which is set according to P8-25 parameters.(3770 version and above support)

Parameter	Name	Default setting	Suitable mode	Meaning	Modify	Effective
P8-25	Panel display settings	0	All	0: normal display, power on display “bb” or “run” 1: display the value of U-00 when powering on, speed feedback, unit: rpm 2: display the value of U0-07 when powering on, torque feedback, unit: %	At once	Repower on

■ Speed, torque control mode

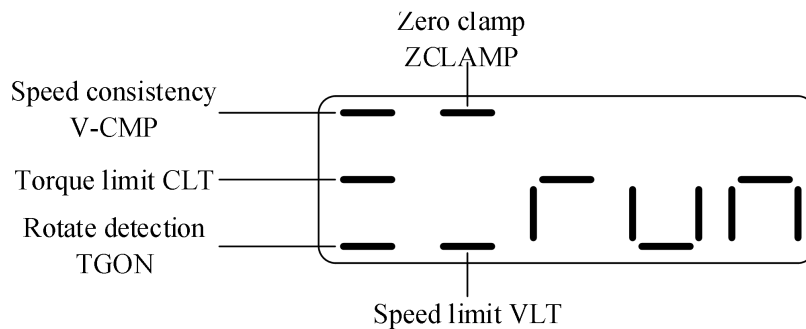

1. Digit display contents

Digit data	Display contents
P5-39 Same speed detection(/V-CMP)	When the actual speed of the motor is the same as the command speed, turn on the light. Detection Width of Same Speed Signal: P5-04 (Unit: rpm)
P5-42 Torque limit(/CLT)	Speed control mode, when the torque exceeds the set value, turn on the light. Internal Forward Torque Limitation: P3-28 Internal Reverse Torque Limitation of: P3-29
P5-40 Rotate detection(/TGON)	When the motor speed is higher than the rotating speed, turn on the lamp. Rotation detection speed: P5-03 (unit: rpm)
P5-31 Zero clamp(/ZCLAMP)	When the zero clamp signal starts to operate, turn on the light.
P5-43 Speed limit(/VLT)	Torque control mode When the speed exceeds the set value, turn on the light Forward speed limit in torque control: P3-16; Reverse speed limit: P3-17.

■ Position control mode

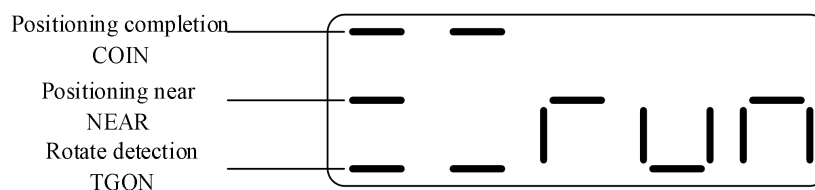

1. Digit display contents

Digit data	Display contents
P5-38 Positioning completion(/COIN)	In position control, when the given position is the same as the actual position, turn on the light. Location Completion Width: P5-00 (Unit: Instruction Pulse)
P5-46 Near (/NEAR)	In position control, when the given position is the same as the actual position, turn on the light. Near signal width: P5-06
P5-40 Rotate detection(/TGON)	When the motor speed is higher than the rotating speed, turn on the lamp. Rotation detection speed: P5-03 (unit: rpm)

4.2.5 Group U monitor parameter

■ U0-21 input signal status

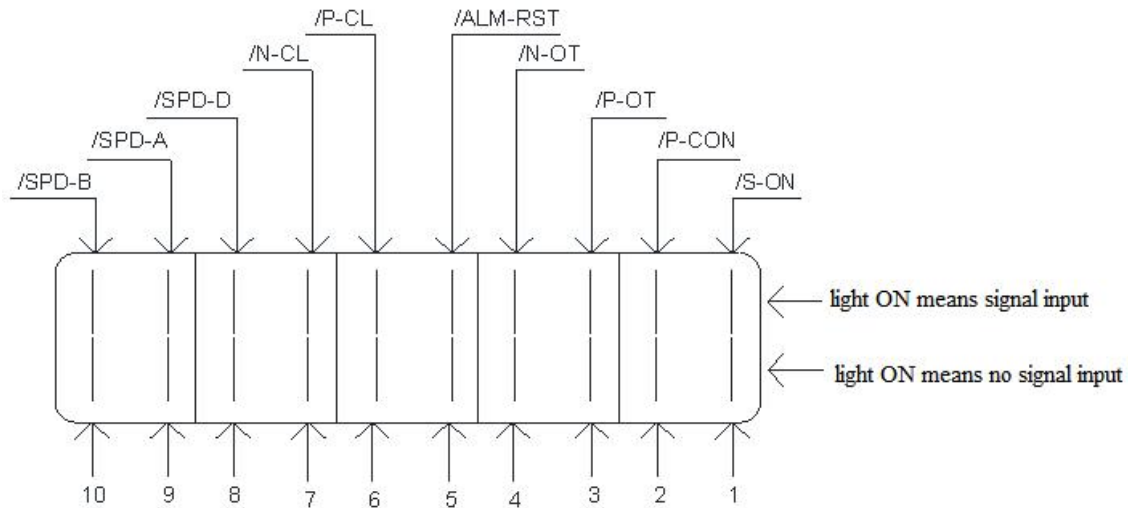

■ U0-21 input signal 1 distribution

Segment code	Description	Segment code	Description
1	/S-ON servo enable	2	/P-CON proportion action instruction
3	/P-OT prohibition of forward drive	4	/N-OT prohibition of reverse drive
5	/ALM-RST alarm reset	6	/P-CL forward side external torque limit
7	/N-CL reverse side external torque limit	8	/SPD-D internal speed direction selection
9	/SPD-A internal speed selection	10	/SPD-B internal speed selection

Note: When reading through communication, the binary numbers read from right to left correspond to the position of /S-ON, /P-CON, 0 means that the position signal is not input, 1 means that the position signal has input. Example: 0x0001 means /S-ON has input, 0x0201 means /S-ON and /SPD-B has input.

■ U0-22 input signal status

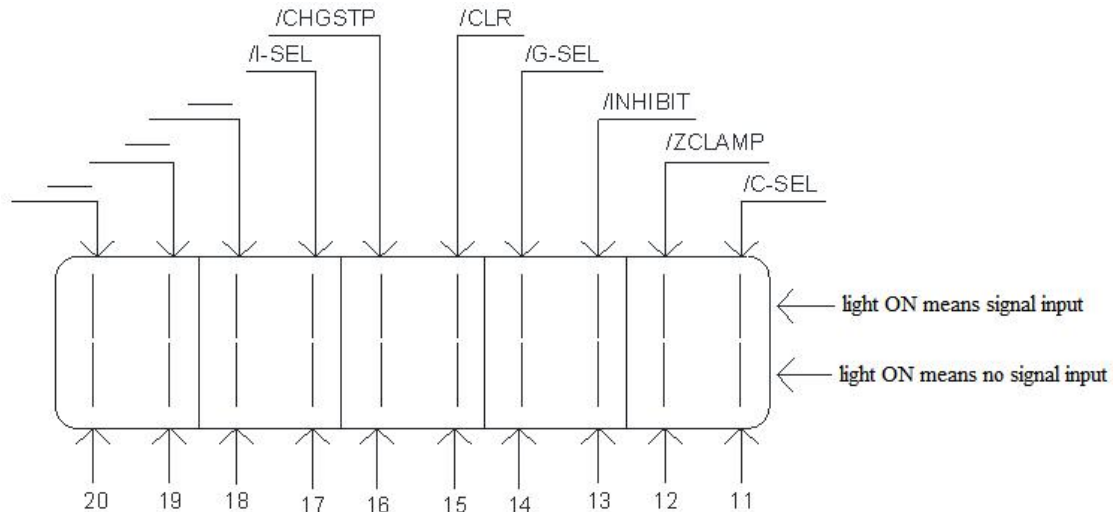

■ U0-22 input signal 2 distribution

Segment code	Description	Segment code	Description
11	/C-SEL control mode selection	12	/ZCLAMP zero clamp
13	/INHIBIT instruction pulse prohibition	14	/G-SEL gain switch
15	/CLR pulse clear	16	/CHGSTPchange step
17	/I-SEL inertia switching	18	—
19	—	20	—

Note: When reading through communication, the binary numbers read from right to left correspond to the position of /C-SEL, /ZCLAMP, 0 means that the position signal is not input, 1 means that the position signal has input. Example: 0x0001 means /C-SEL has input, 0x0041 means /C-SEL and /G-SEL have input.

Note:“-” is for reserved display and does not represent any signal.The status bit is always 0.

■ U0-23 output signal status

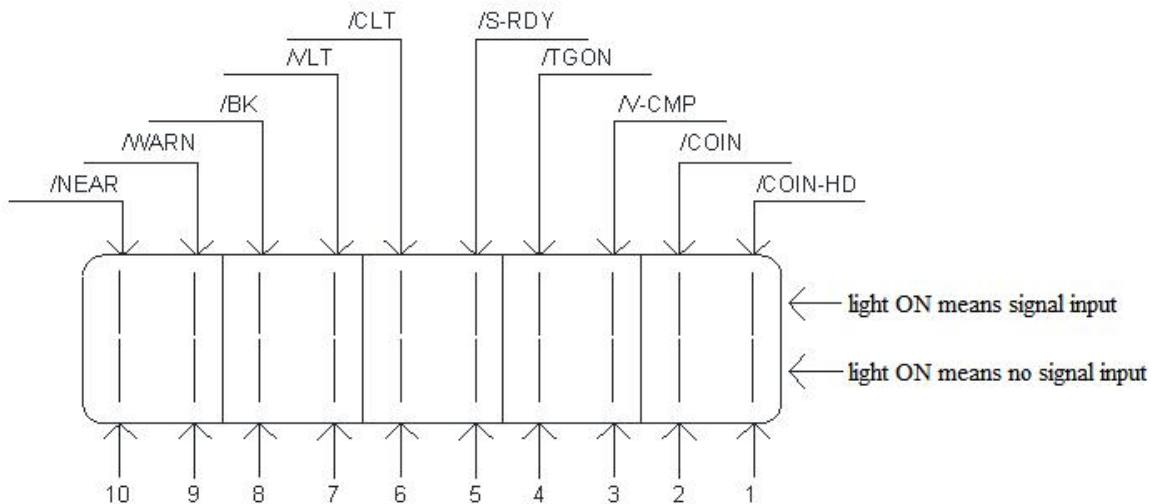

■ U0-23 output signal 1 distribution

Segment code	Description	Segment code	Description
1	Positioning completion hold(/COIN_HD)	2	Position completion(/COIN)
3	Same speed detection(/V-CMP)	4	Rotate detection(/TGON)
5	Ready (/S-RDY)	6	Torque limit(/CLT)
7	Speed limit detection(/VLT)	8	Break lock(/BK)
9	Warn (/WARN)	10	Output near(/NEAR)

Note: when reading status through communication, the binary from right to left correspond to the position of /COIN_HD, /COIN. 0 means that the position signal is not output, 1 means that the position signal has output. Example: 0x0001 means / COIN_HD has output, 0x0201 means /COIN_HD and / NEAR has output.

■ U0-24 output signal status

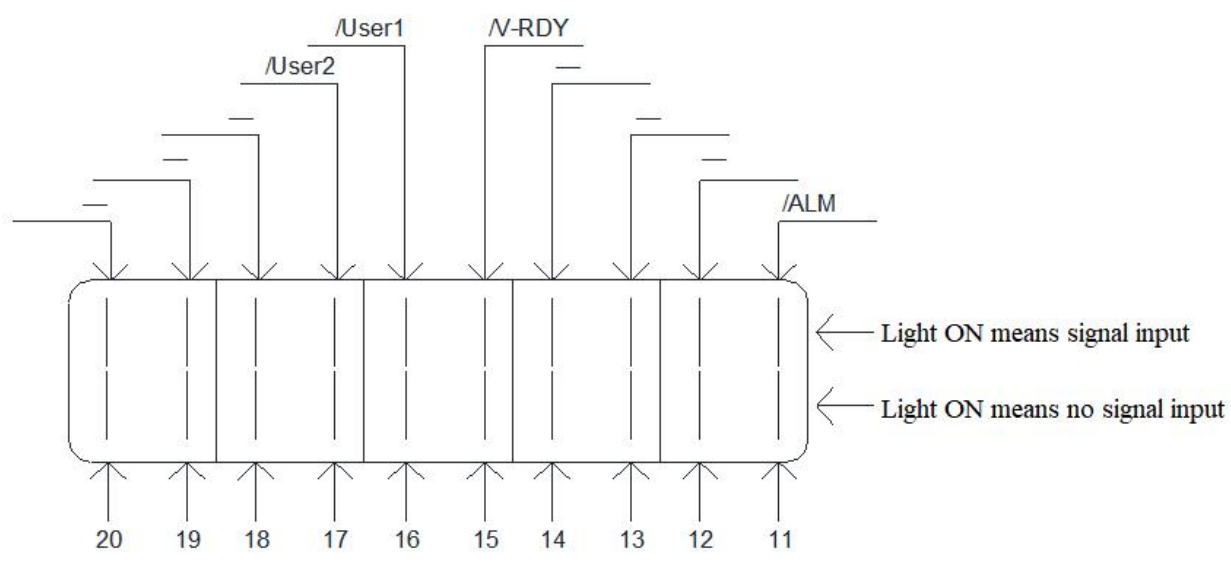

■ U0-24 output signal 2 distribution

Segment code	Description	Segment code	Description
11	Alarm (/ALM)	12	—
13	—	14	—
15	Speed reach (/V-RDY)	16	Customized output 1
17	Customized output 2	18	—
19	—	20	—

Note: when reading the state through communication, the binary numbers correspond to /ALM position in turn from right to left. 0 means that the position signal has no input, and 1 means that the position signal has input. For example, 0x0001 means /ALM has signal output, 0x0041 means /ALM and /customized output 2 have signal output.

Note: “-” is for reserved display and does not represent any signal. The status bit is always 0.

■ U4-18 Output signal status

SI1	SI2	SI3	U4-18 display
1	0	0	0x0001
0	1	0	0x0002
1	1	0	0x0003
0	0	1	0x0004
...

Note: U4-18 displays the state of SI terminal, Only after the function of corresponding terminal is set, the input high level of this terminal will be displayed on U4-18.

For example, SI1 has no function allocation, and even if SI1 is set to high level, the 0th bit of U4-18 will not display 1.

■ U4-19 Output signal status

SO1	SO2	SO3	U4-19 display
1	0	0	0x0001
0	1	0	0x0002
1	1	0	0x0003
0	0	1	0x0004
...

Note: U4-19 displays the state of SO terminal. Only after the function of the corresponding terminal is set, the input high level of this terminal will be displayed on U4-19.
 For example, SO1 has no function allocation, and even if the hardware sets SO1 to high level, the 0th bit of U4-19 will not display 1.

4.2.6 Group F auxiliary parameters

■ F0-XX

Function code	Description
F0-00	Alarm clear
F0-01	Resume to default settings
F0-02	Clear the position offset

1. Alarm clear (F0-00)

In case of failure, it will automatically jump out of the alarm state of E-XXX and display the alarm number. In case of no failure, the alarm state will not be visible.

In the alarm state, write 1 to F0-00 through panel operation to reset the fault.

When an alarm occurs, first eliminate the cause of the alarm, and then clear the alarm. In case of servo alarm due to servo power OFF, it is not necessary to clear the alarm.

2. Resume the factory settings (F0-01)

First turn the servo OFF, and then restore the factory operation. The operation is as follows:

Set F0-01=1 when enabler is shut down, press ENTER to resume to default settings, no need to cut power.

3. Panel inertia identification (F0-07)

Before inertia identification, please use F1-00 jog function to confirm the servo rotation direction. At the beginning of inertia identification, INC or DEC determines the initial direction of servo operation!

If the servo jitters under the adaptive default parameters, please switch to the adaptive large inertia mode (P2-03.3 = 1) to ensure the stable operation of the servo before inertia identification!

When the servo is in bb state, enter the parameter F0-07 display:



Refer to chapter [9-2-4](#) for details

4. Panel external instruction auto-tuning (F0-08)

Refer to chapter [9-4-5](#) for details

5. Panel internal instruction auto-tuning (F0-09)

Refer to chapter [9-4-4](#) for details

6. Panel vibration suppression (F0-10, F0-11)

Vibration suppression mode	Display	Parameter
Mode 1	vib-1	Only the parameters related to vibration suppression will be changed
Mode 2	Vib-2	The parameters related to vibration suppression and the gain of speed loop will be changed

The operation steps are described below:

(1) In the self-tuning mode, enter the parameter F0-10 and the panel displays vib-1 or enter F0-11 and the panel displays vib-2.

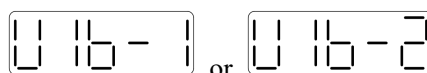

(2) Short press ENTER, the panel display Son and flashes. At this time, it needs to be enables manually

5on

(3)After the servo enable is turned on, the panel displays tune and flashes to enter the tuning state.

tune

(4)The upper device starts to send pulse command until done is displayed and flashes to complete vibration suppression.

done

(5)Press STA/ESC to exit

The vibration suppression parameters will be automatically written into the second and first notch filters.(when there is only one vibration point, the second notch will be opened first).

Refer to 9-7-7.

7. Panel vibration suppression (fast FFT) (F0-12)

The function can analyze the mechanical characteristics through F0-12 parameters on the servo operation panel to find out the mechanical resonance frequency,so as to realize vibration suppression.

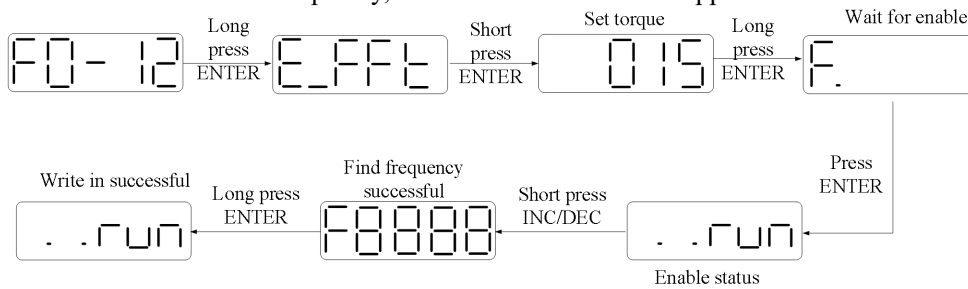

■ F1-XX

Code	Note
F1-00	Jog run
F1-01	Test run
F1-02	Current sampling zero-correction
F1-05	Panel enable
F1-06	Reset turns of absolute encoder

1. Jog run(F1-00)

Before entering jog mode, please confirm that the motor shaft is not connected to the machine and the driver is in bb idle status!

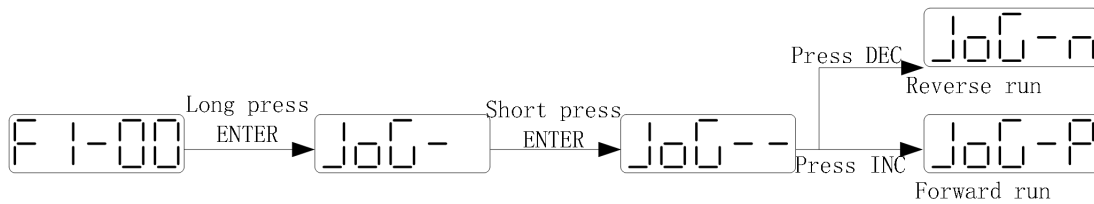

During jog operation, parameters such as gain will participate in the control, and whether the parameter setting is appropriate can be judged according to the operation condition.

P3-18	JOG speed					
	Unit	Default	Range	Suitable mode	Modify	Effective
	1rpm	100	0~1000	JOG	Servo OFF	At once

2. Test run(F1-01)

Before entering the test run mode, please confirm that the motor shaft is not connected to the machine!

When the servo driver is connected to the non-original encoder or power cable, it should first enter the test run mode to verify that the encoder terminal or power terminal is connected correctly.

Test run mainly checks the power cable and the encoder cable to determine whether the connection is normal.According to the following operation,the motor can normally achieve forward and reverse rotation. If the motor shaft shakes or driver alarms, please immediately disconnect the power supply, and re-check the wiring

situation.

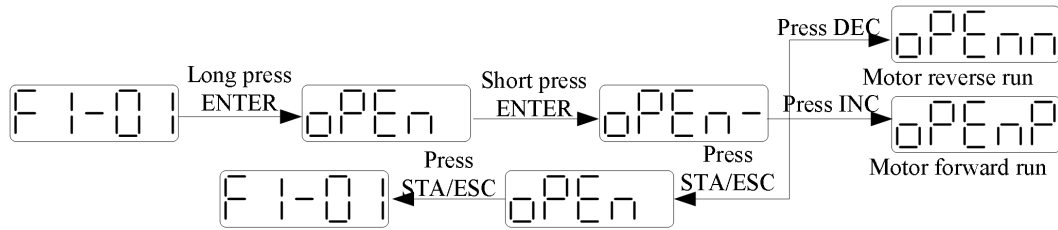

3. Current sampling zero-correction(F1-02)

When the servo driver is updated or the motor runs unsteadily after a long time, it is recommended that the user automatically adjust the current detection offset, and carry out the following operations when the driver is bb idle.

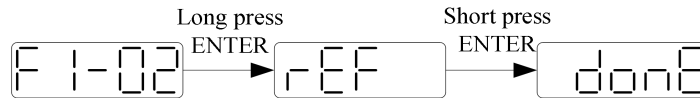

Press STATUS/ESC to exit. It needs to re-power on the driver.

4. Panel enable(F1-05)

Parameter	Signal name	Setting	Meaning	Modify	Effective
P0-03	Enable mode	0	disable	bb	At once
		1(default)	I/O enable/S-0N		
		2	Software enable(F1-05 or communication)		
		3	Bus enable(Models supporting bus)		

Set P0-03=2

F1-05 = 0: cancel enable, enter bb status.

F1-05 = 1: forced enable, servo is in RUN status.

Note:

(1) After power on again, the forced enable set by F1-05 will fail.

(2) If it needs to enable when power on and still enable after re-power on, P0-03 should be set to 1 and P5-20 to n.0010.

5. Reset turns of absolute encoder(F1-06)

First turn the servo OFF, and then clear the number of turns of the absolute encoder. The operation is as follows:

Write 1 to F1-06 through panel operation to clear the number of turns of absolute encoder.

Write 1 to 0x2106 hexadecimal address through Modbus RTU to clear the number of turns (servo bb status takes effect, and write 0x2106 to 0 after clearing)

5 Absolute value system and power-off brake

5.1 Absolute value system

5.1.1 Absolute system setting

In order to save the position data of absolute encoder, the battery unit needs to be installed.

Install the battery on the battery unit of the encoder cable with the battery unit.

If you do not use encoder cable with battery unit, please set P0-79 to 1, that is, multi-loop absolute value encoder is used as incremental encoder.

Parameter	Name	Setting	Meaning	Range
P0-79	Absolute encoder battery undervoltage alarm switch	0	Normally use absolute encoder and use battery to memorize position.	0~2
		1(default)	As incremental encoder, no longer memorize the position of multiple turns	
		2	Use as absolute encoder, but ignores the multi turn overflow alarm. Enable the recording of the number of turns and the number of times of overflow, and power down memory (3770 version and above)	

Note: when the E-222 alarm occurs after replacing the multi turn motor, the overflow times of the multi turn number will be automatically cleared, otherwise serious position deviation will occur, causing danger.

5.1.2 Replace the battery

When replacing the battery, please replace the battery while keeping the driver and motor connected well and the control power is connected. If the battery is replaced when the control power between the driver and the motor is closed, the data stored in the encoder will be lost.

Note: Absolute Encoder Battery Model (This Battery can't Charge)

Battery unit for normal cable:CP-B-BATT

Battery unit for tank chain cable: CPT-B-BATT

Battery replacement steps

When using encoder cable with battery unit

- (1) Only the control power of the servo unit is connected;
- (2) Open the cover of the battery cell;

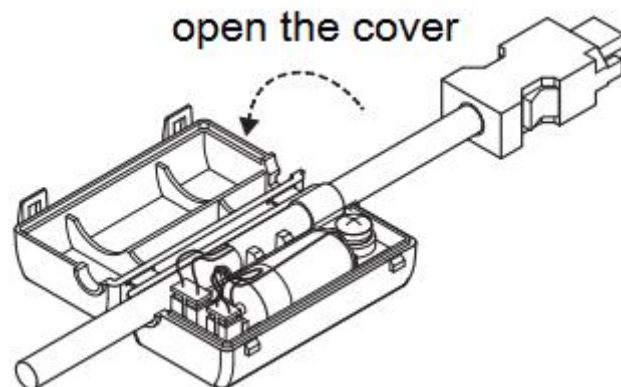

- (3) Take out the old battery, install the new one.

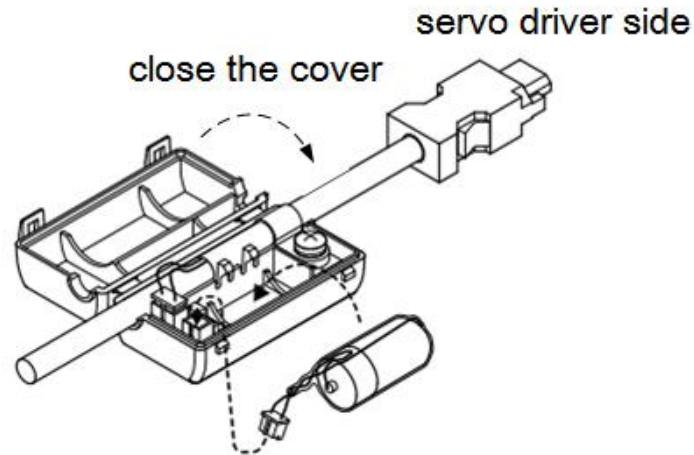

(4) Close the cover of the battery unit

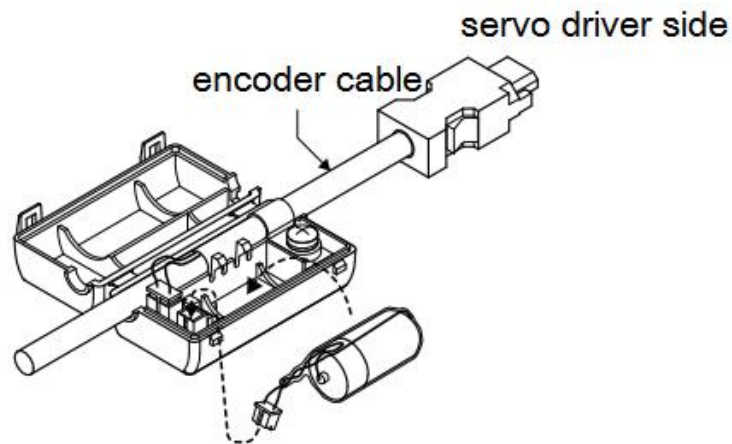

(5) After replacing the battery, in order to remove the "Encoder Battery Alarm (E-222)" display, please do clear alarm twice (F0-00=1). (3770 version and above only need to be cleared once.)

(6) Connect the power supply of the servo unit again;

(7) Make sure the error display disappears and the servo unit can operate normally.

5.1.3 The upper limit of turns

The upper limit of rotating cycles can be used for position control of gyroscopes such as turntables.

For example, suppose there is a machine whose turntable moves only in one direction, as shown in the figure below.

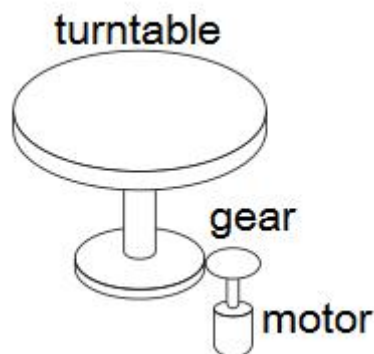

Because it can only rotate in one direction, after a certain period of time, the number of revolving cycles will always exceed the upper limit of absolute value encoder.

Servo motor series	Resolution (single-circle data)	Rotating Circle Serial Data Output range	Operation of overtime
CM/CS	17	-32768~32767	When it is higher than the upper limit value in the forward direction ($+32767*2^{17}$): Rotation serial data = $32767*2^{17}$ When it is below the lower limit of reversal direction ($-32768*2^{17}$):
TL	23		When it is higher than the upper limit value in the forward direction ($+32767*2^{23}$): Rotation serial data = $32767*2^{23}$ When it is below the lower limit of reversal direction ($-32768*2^{23}$): Rotation Serial Data= $-32767*2^{23}$

5.1.4 Reset multi-turn absolute position

Encoder turns clearing should be done when servo driver is bb status. The clearing methods include servo panel clearing and Ethercat communication clearing. Write 1 to F1-06, the current number of turns U0-91 of the multi turn absolute value will be set to 0, and the current position feedback U0-57 ~ U0-59 of the absolute value encoder will also change.

1. Servo panel clearing

Enter parameter F1-06 when servo is in bb state:



Press **【INC】** to 1, and keep press **【ENT】** to confirm and exit:

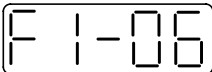

Clear the absolute encoder turns through F1-06 on the servo panel.

2. EtherCAT communication clearing

Method 1: In the servo bb state, write 1 to # 0x4106 through EtherCAT bus communication to clear the number of turns.

Method 2: Via EC_SDO instruction



Write 1 to D0 to clear the number of turns.

5.1.5 Zero calibration of absolute encoder

Parameters	Name
F1-06	Set to 1: absolute encoder position clear Set to 3: zero Calibration of absolute encoder
U0-94	Relative encoder feedback value which can be reset
U0-95	
U0-96	
U0-97	

1. Calibrate through the servo panel

Enter F1-06 when servo is in bb status



Press **【INC】** to 3 and long press **【ENT】** to confirm and exit.

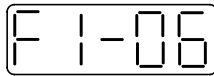

Calibrate the encoder current position as zero position through servo panel F1-06 parameter, U0-94~97 will show the encoder position after calibration.

2. EtherCAT bus communication clearing

Write 3 to #0x4106 through EtherCAT bus communication, and U0-94~97 are used to display the absolute position of the motor after calibration.

5.2 Power-off brake

When the servo motor controls the vertical load, the purpose of using the “brake servo motor” is: when the power supply of the system is placed in the "OFF", the movable part will not move under the action of gravity.

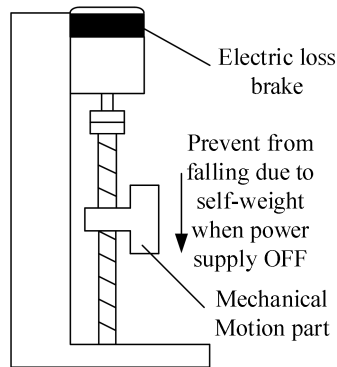

Note: The brake built in the servo motor is a fixed special brake without excitation. It can not be used for dynamic braking. Please use it only when the servo motor is in a stop state.

■ Related parameter

Parameter	Meaning	Default setting	Unit	Setting range	Modify	Effective
P5-44	Brake interlock /BK	n.0000	-	0~ffff	Servo bb	At once
P5-07	Servo OFF delay time	500	1ms	0~65535	Servo bb	At once
				-500~9999 (above 3760 version)		
P5-08	Brake command output speed	30	rpm	20~10000	Servo bb	At once
P5-09	Brake command output speed	500	ms	0~65535	Servo bb	At once
P0-69.2 (above 3760 version)	Source of servo power down signal	0	-	0~1	Anytime	At once

1. Hardware wiring

The ON/OFF circuit of the brake is composed of the sequential output signal of the servo unit "/BK" and "brake power supply". A typical connection example is shown below.

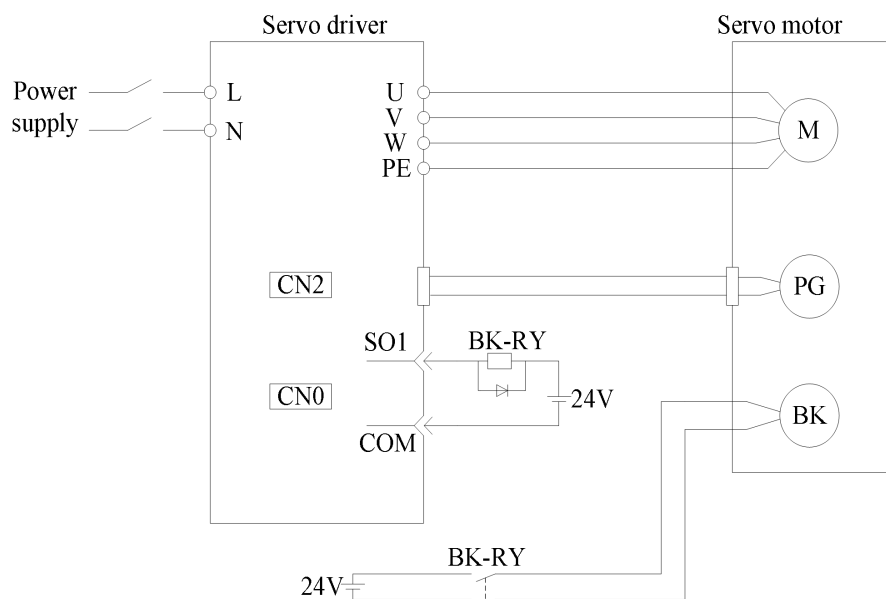

Note:

- ① The excitation voltage of the power-off brake is 24V.
- ② If the holding brake current is more than 50mA, please transfer it through the relay to prevent terminal burnt out due to excessive current.

2. Software parameter settings

For the servo motor with holding brake, it is necessary to configure one SO terminal of servo driver as holding brake output /BK function, and determine the effective logic of SO terminal, that is, parameter P5-44 needs to be set.

Parameter setting	Servo status	Signal/BK terminal output logic	Servo motor status
P5-44=n.000□	Servo bb	Invalid	Brake power off, motor in position locked state
	Servo run	Valid	Brake power on, motor in rotatable state
P5-44=n.001□	Servo run	Invalid	Brake power off, motor in position locked state
	Servo bb	Valid	Brake power on, motor in rotatable state

Note:

- (1) When SO terminal is used to control holding brake, when servo enable is on, holding brake power is on and motor is in rotatable state;
- (2) If the motor fails to rotate during the debugging of the new machine, please confirm whether the holding brake is open.

3. Time sequence of holding brake control

(1)Sequence of holding brake under normal power on state timing in normal power on state: servo on enable and brake ON occur at the same time. The response time from SO terminal output to band brake coil is 50 ~ 60ms.

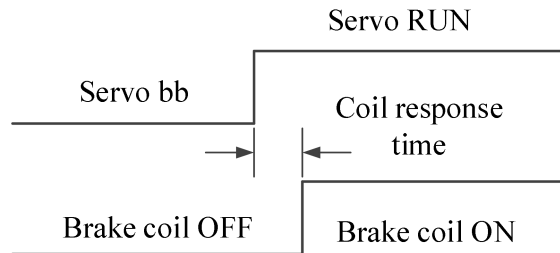

(2)Sequence of holding brake when closing enable during operation:

Direct off enable during movement refers to that when the motor shaft has rotation speed (at this time, the motor rotation speed is > 0), it is directly switched to disable. After the closing enable, the motor decelerates. When the motor decelerates to the speed set in P5-08 within P5-09, the holding brake is closed.

As shown in the left figure, if the motor has not decelerated below the speed of P5-08 at the time set in P5-09, the holding brake is also directly closed, as shown in the right figure:

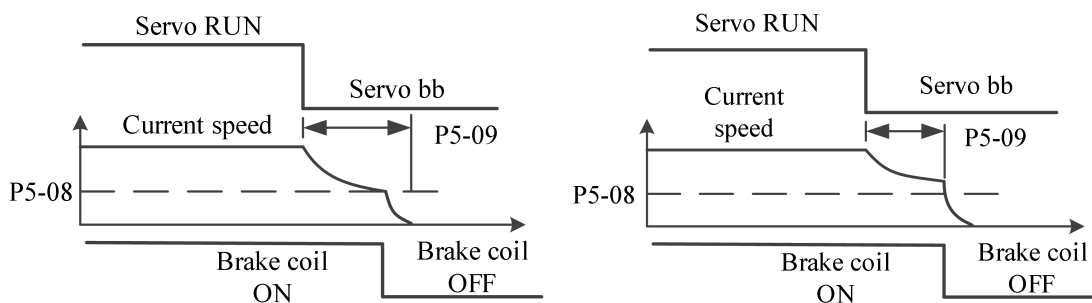

(3)Sequence of closing enable holding brake under static state:

Static state is a special dynamic state with running speed of 0.

If it is switched to servo bb state in static state, the holding brake will be closed in advance (set P5-07 servo off delay time) to prevent falling.

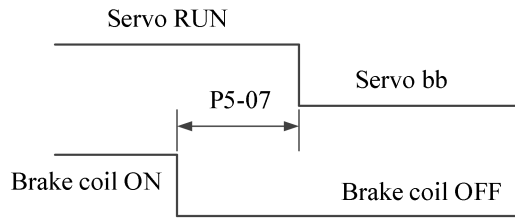

Note: refer to (2), (3) for the holding brake timing during alarm.

(4)Holding brake timing after power failure:

① When P5-07 is set to a negative number, when the power loss signal occurs, the band brake is directly turned off. At this time, the amount of electricity stored in the capacitor needs to be consumed, and the power is turned off after the time of P5-07 is delayed.

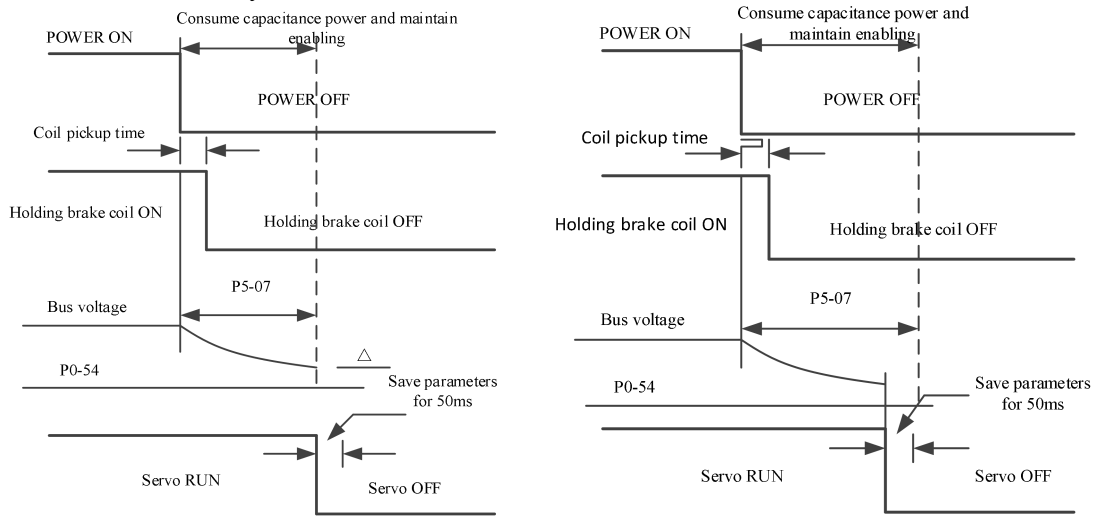

② When the setting value of P5-07 is positive, the power loss signal is received, the holding brake is directly closed and enabled (at this time, the P5-07 delay time does not work).

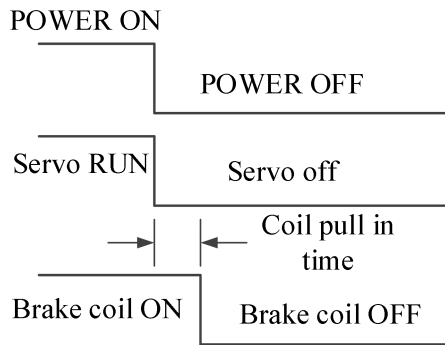

Note: When P0-69.2=1, the detected power failure signal is bus voltage P0-54. When P0-54 reaches the set value (140V by default), close the holding brake with the set value P5-07. Refer to (4) for the holding brake timing.

4. Brake connection

(1) When the drive power is below 750W, it can be directly connected through SO terminal, as shown in the figure below.

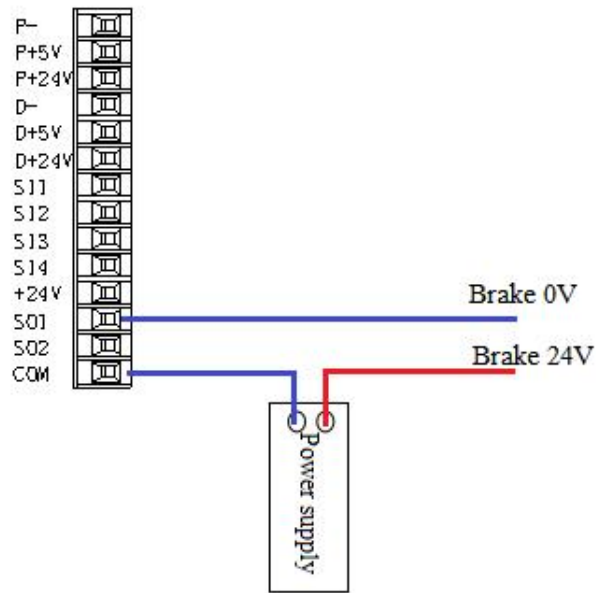

(2) When the power of the driver exceeds 750W and above, it needs to be connected through the intermediate relay. The connection method is as follows.

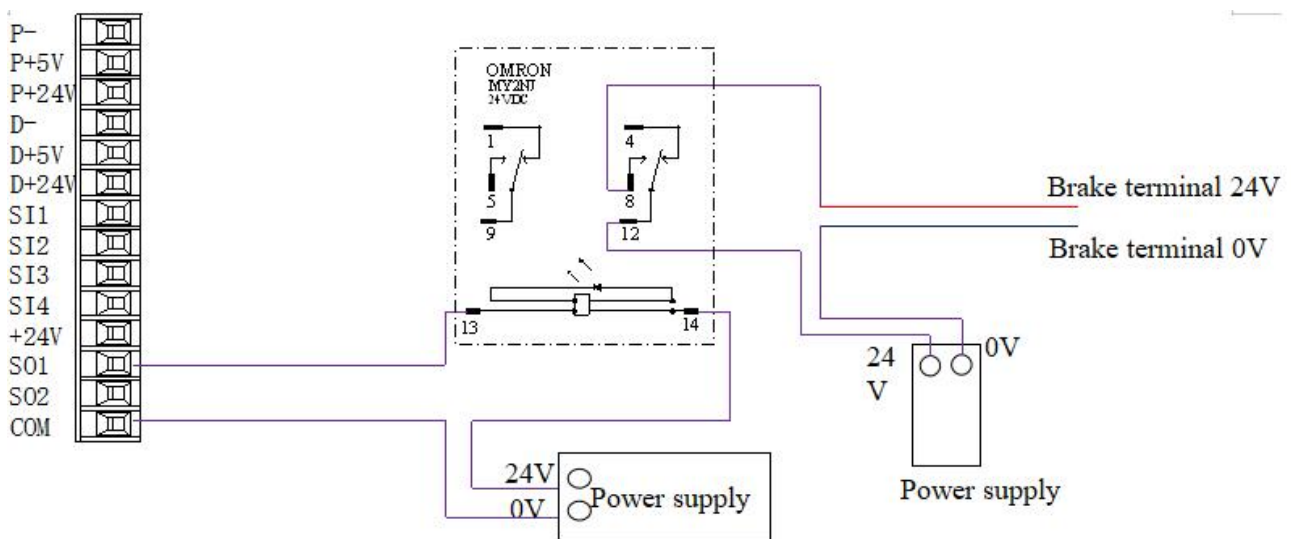

Note: it is recommended that SO terminal and intermediate relay do not share the same switching power supply.

5. When the holding brake slightly drops after power failure, the following solutions can be adopted:

- ① Appropriately reduce p5-07 (3760 and later can be set to negative number)
- ② Directly set p0-69.2 to 1 (3760 and later support)

5.3 Stop mode

Servo shutdown can be divided into free shutdown, deceleration shutdown, and dynamic braking (DB) shutdown according to the shutdown methods. The following is an explanation of the servo shutdown methods.

Stop mode	Free shutdown	Decelerating shutdown	DB shutdown
Shutdown principle	The servo drive is not enabled, the servo motor is not powered on, and it can freely decelerate to 0. The deceleration time is affected by mechanical inertia, equipment friction, and other factors.	The servo driver outputs reverse braking torque, and the motor quickly decelerates to 0.	The servo motor operates in a short-circuit braking state.
Shutdown characteristics	Advantages: Smooth deceleration, low mechanical impact, but slow deceleration process, smooth deceleration, low mechanical impact Disadvantage: Slow deceleration process	Advantages: Short deceleration time Disadvantage: There is mechanical impact	Advantages: Short deceleration time Disadvantage: There is mechanical impact

According to the different scenarios of servo shutdown, it can be divided into servo OFF shutdown, alarm shutdown, and overtravel shutdown.



Currently, only the 1kW~7.5kW models of DS5C1 support dynamic braking (DB) function.

5.3.1 750W and below/11kw and up DS5C1 servo OFF and alarm shutdown

■ Related parameters

Parameter	Meaning	Default setting	Unit	Range	Modify	Effective
P0-30	Stop timeout time	20000	1ms	0~65535	Servo bb	At once
P5-03	Rotation detection speed	50	rpm	0~10000	At once	At once
P0-27	Servo disable shutdown mode	0	-	0/2	Servo bb	At once
P0-29	Alarm stop method	2	-	0/2	Servo bb	At once
Parameter	Value	Meaning				
P0-27	0	Free running stops and remains in a free running state after stopping.				
	2	Deceleration braking stops, and after stopping, it remains in a free running state.				
P0-29	Turn off enable property alarm					
	0/2	Free running stops and remains in a free running state after stopping.				
	Not turn off enable property alarm					
	0	Free running stops and remains in a free running state after stopping.				
	2	Deceleration braking stops, and after stopping, it remains in a free running state.				

Note:

1. turn off servo enable shutdown mode (P0-27)

(1) When P0-27=0, if the servo OFF occurs, the motor starts to rely on free stop without any alarm;

(2) When P0-27=2, if the servo OFF occurs, the motor starts to rely on deceleration to stop, until the speed is less than 50rpm before turning to free stop. At the same time, the servo will time the deceleration stop stage. If the timing time has exceeded P0-30 and the motor speed has not dropped below 50rpm during the deceleration process, an alarm E-262 will show.

2. servo alarm shutdown mode (P0-29)

(1) turn off enable property alarm

When P0-29=0/2, if a servo alarm occurs, the motor begins to rely on free stop.

(2) not turn off enable property alarm

When P0-29=0, if a servo alarm occurs, the motor starts to rely on free stop.

When P0-29=2, if a servo alarm occurs, the motor starts to rely on deceleration to stop, until the speed is less than 50rpm before turning to a free stop. At the same time, the servo will time the deceleration stop stage. If the timing time exceeds P0-30 during the deceleration process, the servo will directly stop freely. At this time, due to the servo being in an alarm state, regardless of the value of P0-29, there will be no alarm E-262. Maintain free running status after stopping.

(3) The servo drive SO terminal is assigned with a holding brake function, and regardless of whether P0-27/P0-29=0 or 2, it stops in a deceleration mode.

(4) The servo drive setting P0-27/29=1/3/4/5 is meaningless, and all is done in a free stop mode.

5.3.2 1~3kw DS5C1 servo OFF and alarm shutdown

■ Related parameters

Parameter	Meaning	Default setting	Unit	Range	Modify	Effective
P0-30	Stop timeout time	20000	1ms	0~65535	Servo bb	At once
P0-27	Servo turn off enable shutdown mode	0	-	0~5	Servo bb	At once
P0-29	Alarm shutdown mode	2	-	0~5	Servo bb	At once

Parameter	Value	Meaning
P0-27	0	Free running stops and remains in a free running state after stopping.
	1	Free running stops and maintains DB status after stopping.
	2	Deceleration braking stops, and after stopping, it remains in a free running state.
	3	Deceleration braking stops and maintains DB status after stopping.
	4	DB stops and remains in a free running state after stopping.
	5	DB stops and remains in DB state after stopping.
P0-29	Turn off enable property alarm	
	0	Free running stops and remains in a free running state after stopping.
	1	Free running stops and maintains DB status after stopping.
	2	DB stops and remains in a free running state after stopping.
	3	DB stops and remains in DB state after stopping.
	4	DB stops and remains in a free running state after stopping.
	5	DB stops and remains in DB state after stopping.
	Not turn off enable property alarm	
	0	Free running stops and remains in a free running state after stopping.
	1	Free running stops and maintains DB status after stopping.
	2	Deceleration braking stops, and after stopping, it remains in a free running state.
	3	Deceleration braking stops and maintains DB status after stopping.
	4	DB stops and remains in a free running state after stopping.
	5	DB stops and remains in DB state after stopping.

Note:

1. servo turn off enable shutdown mode (P0-27)

① When P0-27=0, if the servo OFF occurs, the motor starts to rely on free stop without any alarm.

② When P0-27=1, if the servo OFF occurs, the motor starts to rely on free stop and maintains the DB state after stopping.

③ When P0-27=2, if the servo OFF occurs, the motor starts to rely on deceleration to stop, until the speed is less than 50rpm before turning to free stop. At the same time, the servo will time the deceleration stop stage. If the timing time has exceeded P0-30 and the motor speed has not dropped below 50rpm during the deceleration process, an alarm E-262 will show.

④ When P0-27=3, if the servo OFF occurs, the motor starts to rely on deceleration to stop, until the speed is less than 50rpm before turning to free stop. At the same time, the servo will time the deceleration stop stage. If the timing time has exceeded P0-30 and the motor speed has not dropped below 50rpm during the deceleration process, an alarm E-262 will show. Maintain DB status after stopping.

⑤ When P0-27=4, if the servo OFF occurs, the motor DB stops and remains in a free running state after stopping.

⑥ When P0-27=5, if servo OFF occurs, the motor DB stops and maintains the DB state after stopping.

2. Servo alarm shutdown mode (P0-29)

(1) Turn off enable property alarm

When P0-29=0, if a servo alarm occurs, the motor starts to rely on free stop.

When P0-29=1, if a servo alarm occurs, the motor starts to rely on free stop and remains in DB state after stopping.

When P0-29=2, if a servo alarm occurs, the motor DB stops and remains in a free running state after stopping.

When P0-29=3, if a servo alarm occurs, the motor DB stops and maintains the DB state after stopping.

When P0-29=4, the motor DB stops and remains in a free running state after stopping.

When P0-29=5, if a servo alarm occurs, the motor DB stops and maintains the DB state after stopping.

(2) Not turn off enable property alarm

When P0-29=0, if a servo alarm occurs, the motor starts to stop freely.

When P0-29=1, if a servo alarm occurs, the motor starts to stop freely and remains in DB state after stopping.

When P0-29=2, if a servo alarm occurs, the motor starts to rely on deceleration to stop, until the speed is less than 50rpm before turning to a free stop. At the same time, the servo will time the deceleration stop stage. If the timing time exceeds P0-30 during the deceleration process, the servo will directly stop freely. At this time, due to the servo being in an alarm state, regardless of the value of P0-29, there will be no alarm E-262. Maintain free running status after stopping.

When P0-29=3, if a servo alarm occurs, the motor starts to rely on deceleration to stop, until the speed is less than 50rpm before turning to a free stop. At the same time, the servo will time the deceleration stop stage. If the timing time exceeds P0-30 during the deceleration process, the servo will directly stop freely. At this time, due to the servo being in an alarm state, regardless of the value of P0-29, there will be no alarm E-262. Maintain DB status after stopping.

When P0-29=4, if a servo alarm occurs, the motor DB stops and remains in a free running state after stopping.

When P0-29=5, if a servo alarm occurs, the motor DB stops and maintains the DB state after stopping.

(3) The servo drive SO terminal has been assigned a holding brake function, and the values set in P0-27/P0-29 are invalid. They all stop in a deceleration manner.

Dynamic braking (DB) timing diagram (dynamic braking low-level indicates effective).

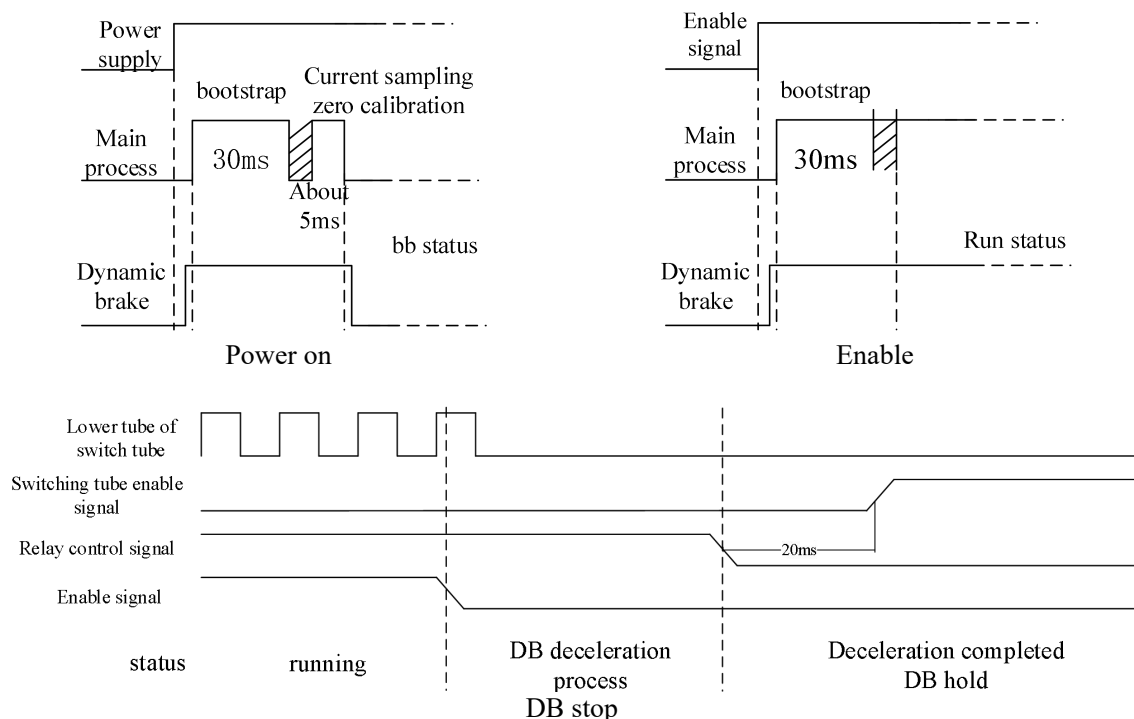

5.3.3 Stop mode when overtravel in normal mode

The overtravel prevention function of servo unit refers to the safety function that the servo motor is forced to stop by inputting the signal of limit switch when the movable part of the machine exceeds the designed safe moving range.

■ Related parameter

parameter	Meaning	Default setting	Unit	Setting range	Modify	Effective
P0-28	Servo override stop mode	2	-	0~3	Servo bb	At once
P0-30	Stop timeout	20000	1ms	0~65535	Servo bb	At once
P5-22	Forward run prohibition /P-OT	n.0003	-		Anytime	At once
P5-23	Reverse run prohibition /N-OT	n.0000	-		Anytime	At once

Be sure to connect the limit switch as shown in the figure below.

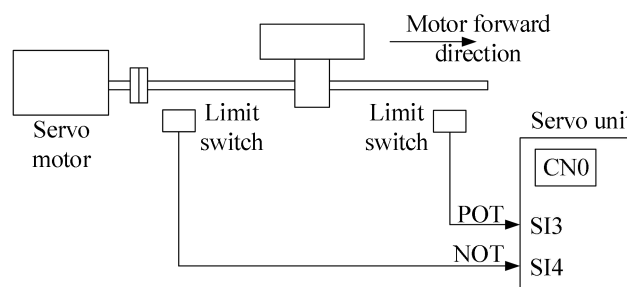

Rotary applications such as round tables and conveyors do not need the function of overrun prevention. At this time, there is no need to connect the overrun prevention with input signals.

Parameter setting	Signal /POT, terminal input status	Overtravel signal (/POT, /NOT) terminal logic
P5-22/P5-23=n.0000	No need to connect external input	invalid
P5-22/P5-23=n.000□	SI□ terminal has no signal input	
P5-22/P5-23=n.001□	SI□ terminal has signal input	
P5-22/P5-23=n.0010	No need to connect external input	valid
P5-22/P5-23=n.000□	SI□ terminal has signal input	
P5-22/P5-23=n.001□	SI□ terminal has no signal input	

Parameter settings in forward limit signal /POT and reverse limit signal /NOT can not be set to the same terminal input at the same time.

Direction	Meet the limit	Operation status
Forward run	positive limit is valid	POT, set the servo overrun stop mode as P0-28
	negative limit is valid	Alarm E-261
Reverse run	positive limit is valid	Alarm E-261
	negative limit is valid	NOT, set the servo overrun stop mode as P0-28

Parameter	Value	Meaning
P0-28	0	The deceleration stops 1, the overrun direction moment is 0 after stopping, and receiving instructions.
	1	Inertia stops, after stopping, overrun direction moment is 0, receiving instructions.

	2	The deceleration stops 2, after stopping, the overrun direction does not receive instructions.
	3	Alarm (E-260)

Note:

- (1) When P0-28 = 0/2, the motor starts to decelerate and stop after receiving the overtravel stop signal, and the braking torque is P3-32 when decelerating stop, and the stop timeout also plays a role in the overtravel process.
- (2) During position control, when the motor is stopped by over travel signal, there may be position deviation pulse. To clear the position deviation pulse, the clear signal /CLR must be input. If the servo unit still receives pulses, they will accumulate until the servo unit gives an alarm.
- (3) During torque control, the SO terminal of servo drive has the function of holding brake, which can't be distributed through the overtravel signal terminals P5-22 and P5-23.
- (4) Servo driver SO terminal is assigned with holding brake function, P0-28 is automatically set to 2.

6 EtherCAT bus communication

6.1 EtherCAT technical overview

This section mainly introduces the basic concept, system composition, communication specifications and connection instructions of EtherCAT.

6.1.1 EtherCAT introduction

EtherCAT, the full name is Ethernet for Control Automation Technology, which is developed by Beckhoff Automation GmbH. It is a kind of real-time Ethernet used for open network communication between master station and slave station. As a mature industrial Ethernet technology, EtherCAT has the characteristics of high performance, low cost and easy to use.

XG2 series controller (master station) and DS5C1 servo driver (slave station) comply with the standard EtherCAT protocol, supports the maximum 32-axis slave stations, 32-axis synchronization cycle is 1ms, 2-way touch probe function, position, speed, torque and other control modes, is widely applicable to various industries.

6.1.2 System composition(master and slave station)

The connection form of EtherCAT is: the network system of linear connection master station (FA controller) and multiple slave stations.

The number of nodes that can be connected by the slave station depends on the processing or communication period of the master station, the number of bytes transmitted, etc.

6.2 EtherCAT communication specification

This section mainly introduces EtherCAT's frame structure, state machine, ESC, SDO, PDO, SII area, communication synchronization mode, etc.

6.2.1 Communication specification

Item	Specification																				
Physical layer	100BASE-TX(IEEE802.3)																				
Baud rate	100[Mbps](full duplex)																				
Topology	Line																				
Connection cable	JC-CB/JC-CA twisted pair(shield twisted pair)																				
Cable length	Maximum 50m between nodes																				
Com port	2 Port(RJ45)																				
EtherCAT indicators (LED)	[Run] RUN indicator [L/A IN] Port0 Link/Activity indicator(Green) [L/A OUT] Port1 Link/Activity indicator(Green)																				
Station Alias(ID)	Setting range: 0~65535 Setting address:2700h																				
Explicit Device ID	Not support																				
Mailbox protocol	COE(CANopen Over EtherCAT)																				
SyncManager	4																				
FMMU	3																				
Modes of operation	<table border="1"> <thead> <tr> <th colspan="3">Modes of operation</th> </tr> </thead> <tbody> <tr> <td rowspan="3">Position</td> <td>Csp</td> <td>Cyclic synchronous position mode</td> </tr> <tr> <td>PP</td> <td>Profile position mode</td> </tr> <tr> <td>Hm</td> <td>Homing mode</td> </tr> <tr> <td rowspan="2">Speed</td> <td>Csv</td> <td>Cyclic synchronous velocity mode</td> </tr> <tr> <td>Pv</td> <td>Profile velocity mode</td> </tr> <tr> <td rowspan="2">Torque</td> <td>Cst</td> <td>Cyclic synchronous torque mode</td> </tr> <tr> <td>Tq</td> <td>Torque profile mode</td> </tr> </tbody> </table>	Modes of operation			Position	Csp	Cyclic synchronous position mode	PP	Profile position mode	Hm	Homing mode	Speed	Csv	Cyclic synchronous velocity mode	Pv	Profile velocity mode	Torque	Cst	Cyclic synchronous torque mode	Tq	Torque profile mode
Modes of operation																					
Position	Csp	Cyclic synchronous position mode																			
	PP	Profile position mode																			
	Hm	Homing mode																			
Speed	Csv	Cyclic synchronous velocity mode																			
	Pv	Profile velocity mode																			
Torque	Cst	Cyclic synchronous torque mode																			
	Tq	Torque profile mode																			
Touch Probe	2 channels																				

Synchronization mode	DC(SYNCOevent synchronization mode) SM(SM event synchronization)
Cyclic time (DC communication period)	250, 500,1000,2000,4000, 8000, 10000[μs]
Communication object	SDO[service data object], PDO[process data object]
Maximum PDO allocation per station	TxPDO:4 [piece] RxPDO:4 [piece]
Single station PDO Max bytes	TxPDO:24[byte] RxPDO:24[byte] (version before 3791) TxPDO:32[byte] RxPDO:32[byte] (version 3791 and later)
Mailbox communication interval in PreOP mode	1ms
Mailbox	SDO request and SDO information

Note:SDO and PDO refer to state machine.

6.2.2 EtherCAT frame structure

EtherCAT is an industrial communication protocol based on real-time control of Ethernet. It only expands the IEEE 802.3 Ethernet specification and does not change the basic structure, so it can transmit the data within the standard Ethernet frame.

Because the EthernetType of the Ethernet Header is [88A4h], the subsequent Ethernet data is processed as the EtherCAT frame.

The EtherCAT frame is composed of the EtherCAT frame header and more than one EtherCAT sub message, which is further subdivided. Only the EtherCAT frame with type = 1 of the EtherCAT frame header is processed according to ESC.

EtherNet/EtherCAT frame structure

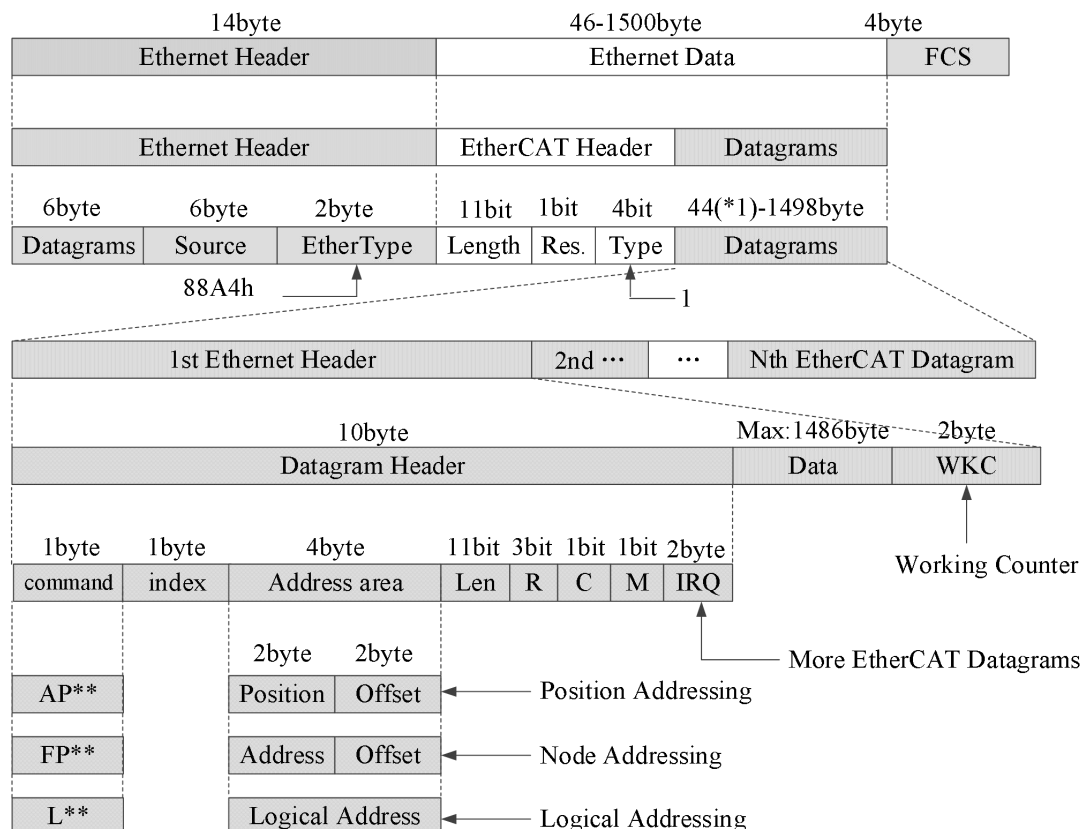

*1:When Ethernet frame is shorter than 64byte, add 1~32byte.
(Ethernet Header + Ethernet Data + FCS)

6.2.3 State machine ESM

The EtherCAT state machine (ESM) is responsible for coordinating the state relationship between the master and slave applications at initialization and runtime.

The state change request is executed by the master station, and the master station puts forward the control request to the application layer service. The latter generates the application layer control event in the slave station, and the slave station responds to the application layer control service through the local application layer state write service after the state change request succeeds or fails. If the state change fails, the slave station keeps the state and shows the error flag.

The figure below shows the state transformation diagram of ESM:

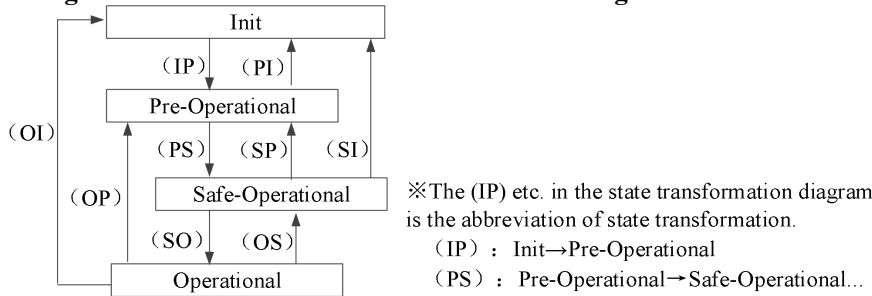

- Init: Initialization status
- Pre-Operational: Pre operation status
- Safe-Operational: Safe operation status
- Operational: Running state

Slave station status	Actions in various states	Communication action		
		SDO(mailbox) receive and send messages	PDO Send messages	PDO Receive messages
Init	Communication initialization, SDO, PDO unable to receive and send messages	-	-	-
Pre-Operational (PreOP)	Only SDO receives and sends messages	Yes	-	-
Safe-Operational (SafeOP)	Only SDO receives and sends messages, PDO sends messages	Yes	Yes	-
Operational (OP)	SDO receives and sends messages, PDO receives and sends messages	Yes	Yes	Yes

Note: the access from the master station to the ESC register is independent of the above table and is available at any time.

PDO (Process Data Object) Used to transmit periodic communication data.

SDO (Service Data Object) Used to transmit aperiodic communication data.

Command or interface operation during ESM state switching may cause abnormal communication error

6.2.4 Slave station controller ESC

6.2.4.1 Principle overview

ESC refers to the EtherCAT slave controller. The communication process is completely processed by ESC, which has four data receiving and transmitting ports, each with a Tx and Rx. Each port can send and receive Ethernet data frames. The data flow direction in ESC is fixed: port 0 → port 3 → port 1 → port 2 → port 0 are transmitted in sequence. If ESC detects that a port has no external PHY, it will automatically close the port and forward to the next port through the internal loopback.

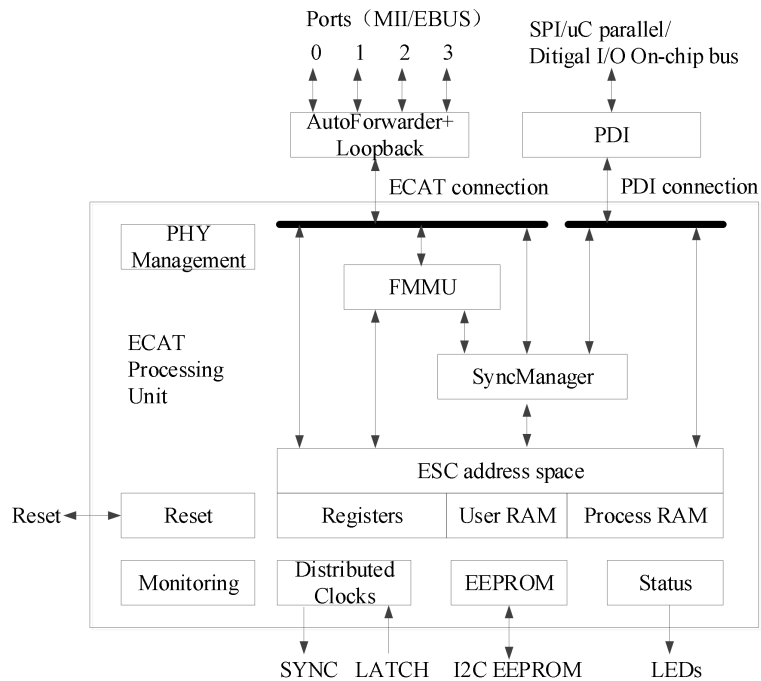

6.2.4.2 Address space

The DS5C1 series have 8 Kbyte of physical address space.

The first 4kbyte (0000h-0FFFh) is used as register space, and the other 4kbyte (1000h-1FFFh) is used as process data PDO in RAM field. For details of registers, please refer to the data table of IP (ET1810 / ET1811 / ET1812).

ESC Register byte address	Length (Byte)	Description	Initial value *1
ESC Information (Slave controller information)			
0000h	1	Type	04h
0001h	1	Revision	02h
0002h~0003h	2	Build	0040h
0004h	1	FMMUs supported	03h
0005h	1	SyncManagers supported	04h
0006h	1	RAM Size	08h
0007h	1	Port Descriptor	0Fh
0008h~0009h	2	ESC Features supported	0184h
Station Address			
0010h~0011h	2	Configured Station Address	-
0012h~0013h	2	Configured Station Alias	-
...			
Data Link Layer			
...			
0100h~0103h	4	ESC DL Control	-
...			
0110h~0111h	2	ESC DL Status	-
Application Layer			
0120h~0121h	2	AL Control	-
0130h~0131h	2	AL Status	-
0134h~0135h	2	AL Status Code	-
...			
PDI process data interface			
0140h	1	PDI Control	08h
0141h	1	ESC Configuration	0Ch

ESC Register byte address	Length (Byte)	Description	Initial value *1
0150h	1	PDI Configuration	-
0151h	1	SYNC/LATCH PDI Configuration	66h
0152h~153h	2	Extend PDI Configuration	-
...			
Watchdog			
0400h~0401h	2	Watchdog Divider	-
0410h~0411h	2	Watchdog Time PDI	-
0420h~0421h	2	Watchdog Time Process Data	-
0440h~0441h	2	Watchdog Status Process Data	-
0442h	1	Watchdog Counter Process Data	-
0443h	1	Watchdog Counter PDI	-
...			
FMMU			
0600h~062Fh	3x16	FMMUs[2:0]	-
+0h~3h	4	Logical Start Address	-
+4h~5h	2	Length	-
+6h	1	Logical Start bit	-
+7h	1	Logical Stop bit	-
+8h~9h	2	Physical Start Address	-
+Ah	1	Physical Start bit	-
+Bh	1	Type	-
+Ch	1	Activate	-
+Dh~Fh	3	Reserved	-
...			
Distributed Clocks(DC)-SYNC Out Unit			
0981h	1	Activation	-
...			
0984h	1	Activation Status	-
098Eh	1	SYNCO Status	-
...			
0990h~0993h	4	Start Time Cyclic Operation/Next SYNC0 Pulse	-
...			
09A0h~09A3h	4	SYNC0 Cycle Time	-
...			

6.2.5 SII area (0000h~003Fh)

In the ESC configuration area (EEPROM word address 0000h-0007h), after the power of the driver is started, the Configured Station Alias automatically reads and writes the ESC register according to ESC. When the value of SII EEPROM is reflected in the ESC register, the power supply needs to be started again. In addition, the initial value of IP core (ET1810 / ET1811 / ET1812) is set. Please refer to the data table of IP core (ET1810 / ET1811 / ET1812) for details.

6.2.6 SDO(Service Data Object)

DS5C1 series supports SDO (Service Data Object). The data exchange of SDO uses mailbox communication, so the data refresh time of SDO becomes unstable.

The master station reads and writes data in the records of the object dictionary, which can set the object and monitor various states of the slave station. The response to a read-write action to SDO takes time. For objects refreshed with PDO, please do not refresh with SDO, and overwrite with PDO value.

6.2.6.1 Mailbox frame structure

Mailbox/SDO frame structure is shown as below. Please refer to ETG specification book (ETG1000-5 and ETG1000-6).

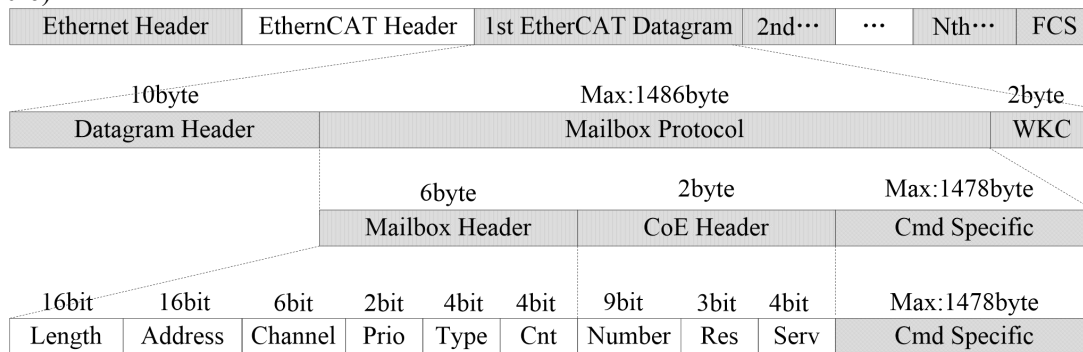

Frame	Data area	Data type	Function
MailBox Header	Length	WORD	Mailbox data length
	Address	WORD	Sending source station address
	Channel	Unsigned6	(Reserved)
	Priority	Unsigned2	Priority
	Type	Unsigned4	Mailbox type 00h: error 01h: (Reserved) 02h: EoE (no response) 03h: CoE 04h: FoE (no response) 05h: SoE (no response) 06h-0Eh: (Reserved) 0Fh: VoE (no response)
	Cnt	Unsigned3	Mailbox counter
	Reserved	Unsigned1	(Reserved)
CoE Header	Number	Unsigned9	Reserved
	Reserved	Unsigned3	Reserved
	Service	Unsigned4	Information type
Cmd specific	Size Indicator	Unsigned1	Data Set Size use license
	Transfer Type	Unsigned1	Normal Forwarding/Expedited Forwarding
	Data Set Size	Unsigned2	Specify data size
	Complete Access	Unsigned1	Object access method selection (not corresponding)
	Command Specfier	Unsigned3	Upload / download Selection of requirements / responses, etc
	Index	WORD	Object Index
	Subindex	BYTE	Object Subindex
			Object data or Abort message, etc.

6.2.6.2 Mailbox overtime

This servo driver performs the following timeout settings in mailbox communication.

Timeout of mailbox request: 100ms

The master station sends a request to the slave station (driver). If the WKC of the transmission data of the request frame is updated, the slave station is considered to receive the request normally. Until WKC is updated, retry again and again. However, if WKC is not updated until this set time, the master station will time out. Timeout for mailbox response: 10s

The master receives a response from a request from a slave (driver), which is considered normal if the WKC is updated. Until this set time, if the response of updated WKC cannot be received, the master station will time out.

The maximum time required for the response of the slave (driver) to complete.

6.2.6.3 Alarm information

1) Error code

Error code returns the same value as 603Fh (Error code).

0000h~FEFFh are defined as IEC61800-7-201.

FF00h~FFFFh are defined by manufacturer, shown as below.

Index	Sub-index	Name/Description	Range	Data type	Access	PDO	Op-mode
603Fh	00h	Error code	0-65535	U16	ro	TxPDO	All
		<p>Now the alarm of the servo driver (only the main number). When the alarm does not occur, it will display 0000H. When an alarm occurs, an alarm is displayed. FF**h Alarm (main) code (00h~FFh) Eg. FF03h ... 03h=3d E-030 (over voltage protection) FF55h ... 55h=85d E-850 (TxPDO configuration error protection), E-851 (RxPDO configuration error protection), any of them occurred. As an exception, A000h is displayed in the case of E-817 (Syncmanager 2/3 setting error).</p>					

2) Error register

Error register returns same value as 1001h (Error register).

Index	Sub-index	Name/Description	Range	Data type	Access	PDO	Op-mode															
1001h	00h	Error register	0-65535	U16	ro	TxPDO	All															
		<p>Displays the type of alarm (status) that is occurring to the servo driver. When the alarm does not occur, it will display 0000H. Do not display warnings.</p> <table border="1" style="margin-left: 40px;"> <thead> <tr> <th>Bit</th> <th>Contents</th> </tr> </thead> <tbody> <tr> <td>0</td> <td rowspan="4" style="text-align: center;">Not support</td> </tr> <tr> <td>1</td> </tr> <tr> <td>2</td> </tr> <tr> <td>3</td> </tr> <tr> <td>4</td> <td>AL status code defined alarm occurred *1</td> </tr> <tr> <td>5</td> <td>Not support</td> </tr> <tr> <td>6</td> <td>Reserved</td> </tr> <tr> <td>7</td> <td>AL status code defined alarm occurred*2</td> </tr> </tbody> </table> <p>*1:“AL status code defined alarm” means EtherCAT communication related error E-800~7, E-810~7, E-850~7. *2:“AL status code not defined alarm” means EtherCAT communication related error E-880~7 and except EtherCAT communication related error.</p>						Bit	Contents	0	Not support	1	2	3	4	AL status code defined alarm occurred *1	5	Not support	6	Reserved	7	AL status code defined alarm occurred*2
Bit	Contents																					
0	Not support																					
1																						
2																						
3																						
4	AL status code defined alarm occurred *1																					
5	Not support																					
6	Reserved																					
7	AL status code defined alarm occurred*2																					

6.2.7 PDO(Process Data object)

DS5C1 series supports PDO (process data object).

The real-time data transfer based on EtherCAT is carried out through the data exchange of PDO (process data object).

PDO has RxPDO transferred from master station to slave station and TxPDO transferred from slave station to master station.

	Send	Receive
RxPDO	Main station	Slave station
TxPDO	Slave station	Main station

6.2.7.1 PDO mapping objects

PDO mapping refers to the mapping from object dictionary to application object of PDO.

Tables for DS5C1 series PDO mapping can use 1600h-1603h mapping objects for RxPDO and 1A00h-1A03h mapping objects for TxPDO.

The maximum number of application objects that a mapping object can map is as follows:

RxPDO: 24 [byte] , TxPDO: 24 [byte]

The following is an example of setting up a PDO map.

< Setting example >

Allocation of application objects 6040h, 6060h, 607ah, 60b8h to 1600h (receive PDO mapping 1: RxPDO_1).

Index	Sub	Object contents	
1600h	00h	04h	
	01h	6040 00 10 h	
	02h	6060 00 08 h	
	03h	607A 00 20 h	
	04h	60B8 00 10 h	
	05h	0000 00 00 h	
	...		
	18h	0000 00 00 h	
6040h	00h	Controlword	U16
6060h	00h	Mode of operation	I8
607Ah	00h	Target Position	I32
60B8h	00h	Touch probe function	U16

6.2.7.2 PDO distribution objects

In order to exchange PDO data, a table for PDO mapping must be assigned to SyncManager. The relationship between the table used for PDO mapping and SyncManager is described to PDO allocation object. DS5C1 series, as PDO allocation object, can use 1C12h for RxPDO (SyncManager2) and 1C13h for TxPDO (SyncManager3).

The maximum number of application objects that a mapping object can map is as follows:

RxPDO: 4 [Table] (1600h~1603h)

RxPDO: 4 [Table](1A00h~1A03h)

Generally, since one mapping object is enough, no change is required by default.

Example of setting PDO assignment object:

Allocation mapping object 1600h to allocation object 1C12h (Sync Manager Channel 2).

Index	Sub	Object contents
1C12h	00h	01h
	01h	1600h
	02h	0000h
	03h	0000h
	04h	0000h

Allocation mapping object 1600h to allocation object 1C13h (Sync Manager Channel 3).

Index	Sub	Object contents
1C13h	00h	01h
	01h	1A00h
	02h	0000h
	03h	0000h
	04h	0000h

6.2.8 Communication synchronization mode

DS5C1 series can select the following synchronization modes.

Synchronization modes	Contents	Synchronization methods	Features
DC	SYNC0 Event synchronization	Synchronize the time information of other slave stations based on the time of the first axis	High-precision Compensation treatment shall be carried out at the main station
SM2	SM2 Event synchronization	Synchronize according to RxPDO's receiving time	No transmission delay compensation, poor accuracy Need to keep transmission time on controller

			side (special hardware, etc.)
FreeRun	Asynchronous	Asynchronous	Simple handling Poor real-time performance

6.2.8.1 DC(SYNC0 event synchronization)

DS5C1 series have 64bit DC (Distributed Clock).

The synchronization of EtherCAT communication is based on this DC. According to the DC slave station, synchronization is realized through the system time with the same reference. The local cycle of the slave station starts with the SYNC0 event. Since the slave processing (servo processing) starts from the SYNC0 event cycle, it is always synchronized with the SYNC0 event.

The master station needs to carry out transmission delay compensation (offset compensation) and regular deviation compensation during communication initialization. The following figure shows the process of synchronous completion from the input of control power to the event of SYNC0 and the processing of slave station (servo processing).

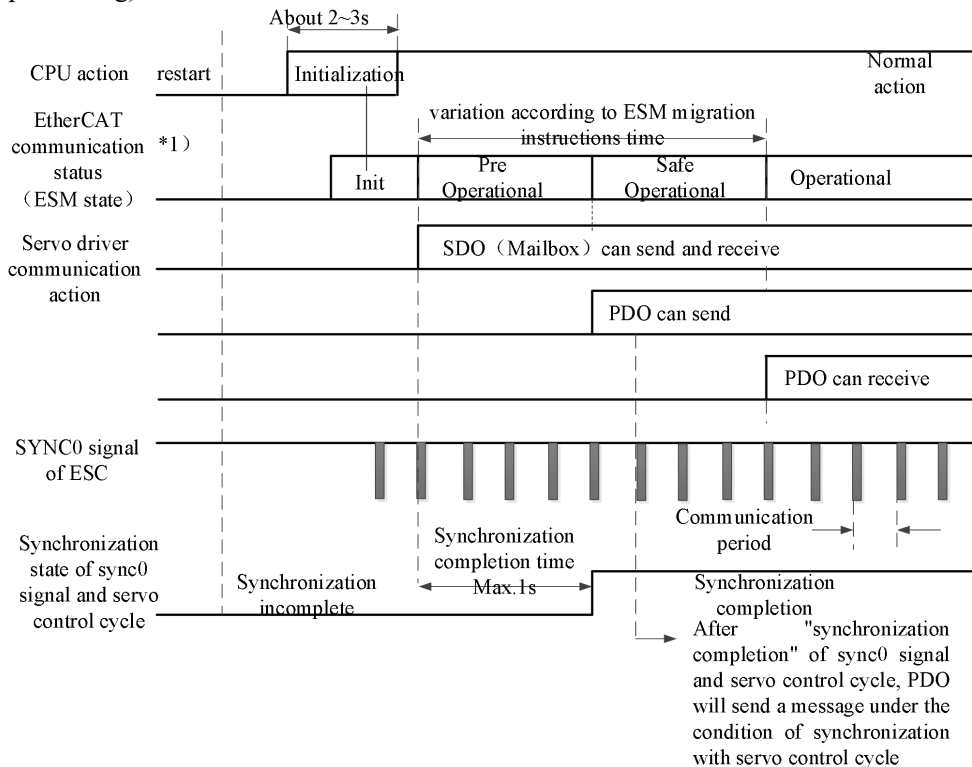

6.2.8.2 SM2(SM2 event synchronization)

The local cycle of the slave station starts with SM2 events.

Since the processing of the slave station starts from the SM2 event cycle, it is always synchronized with SM2 events.

Because SM2 event occurs when PDO receiving is completed, it is necessary to ensure that the upper (Master) side sends the message regularly. If the fluctuation (deviation) of sending time is too large, synchronization cannot be completed, or an alarm occurs.

If this happens, please use DC (SYNC0 event synchronization).

6.2.9 LED indicator

The DS5C1 series has two indicators (LEDs) in network port, orange and green light.

The orange light is always off, and the green light has three states: OFF, ON, flash.

After the communication is established successfully, the green light will flash.

If the green light is always ON or OFF, it indicates that the communication is disconnected abnormally or communication is not established

7 EtherCAT bus control mode

7.1 EtherCAT operation

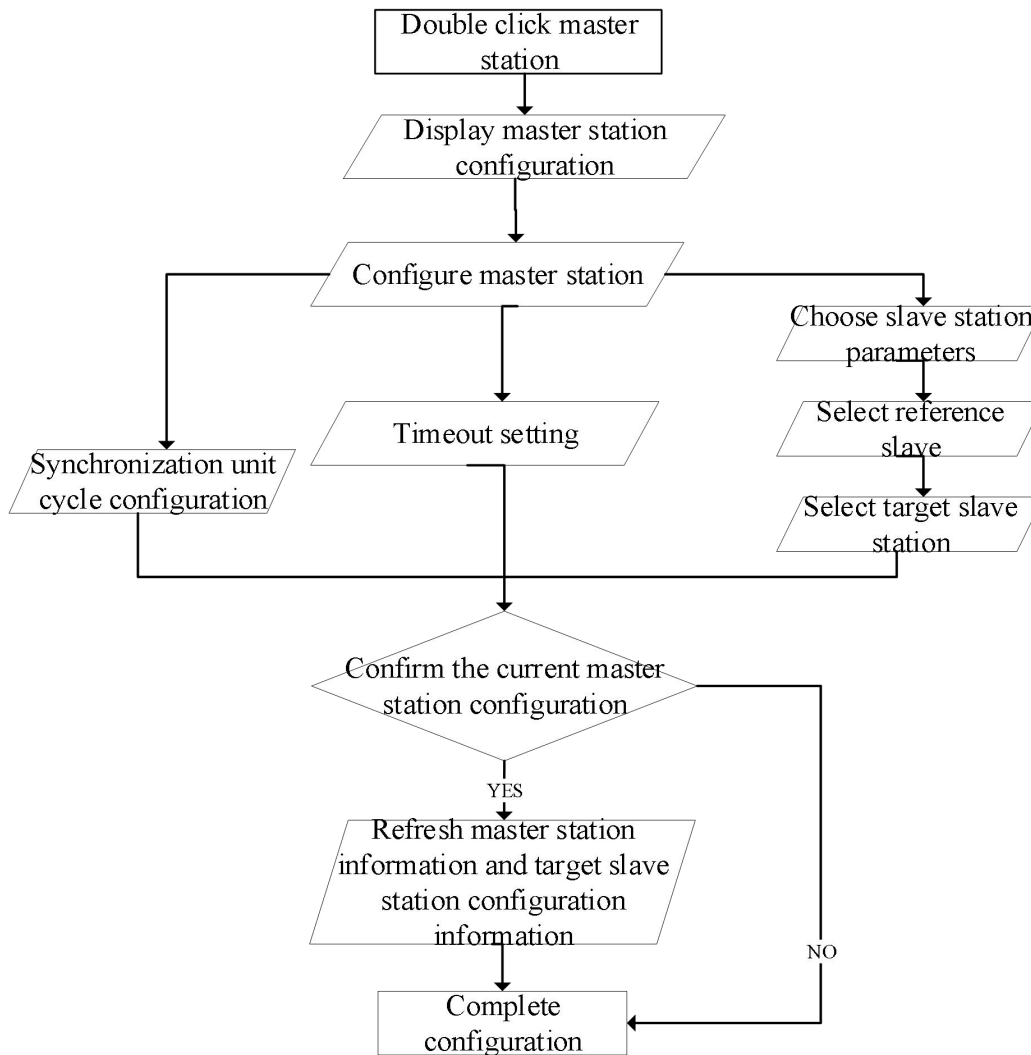

The following table shows the parameters that must be configured uniformly in CSP, CSV, CST, PP, PV and TQ modes.

Register	Explanation
RXPDO[0x6040]	Controlword must be added to the PDO configuration. It is invalid to modify it through IO mapping in CSP, CSV and CST modes. It is controlled by the NC module
RXPDO[0x6060]	Modes of operation, must be added to the PDO configuration, and can be modified by IO mapping in the task mode.
RXPDO[0x607A]	Target position, the given location of the program, must be added to the PDO configuration
TXPDO[0x6041]	Statusword, must be added to PDO configuration
TXPDO[0x6061]	Modes of operation display, must be added to PDO configuration
TXPDO[0x6064]	Position actual value, must be added to PDO configuration
TXPDO[0x606C]	Velocity actual value, must be added to PDO configuration

7.2 CSP mode

CSP (periodic synchronous position mode), whose motion trajectory is calculated by the upper computer, periodically sends the target position to the slave station.

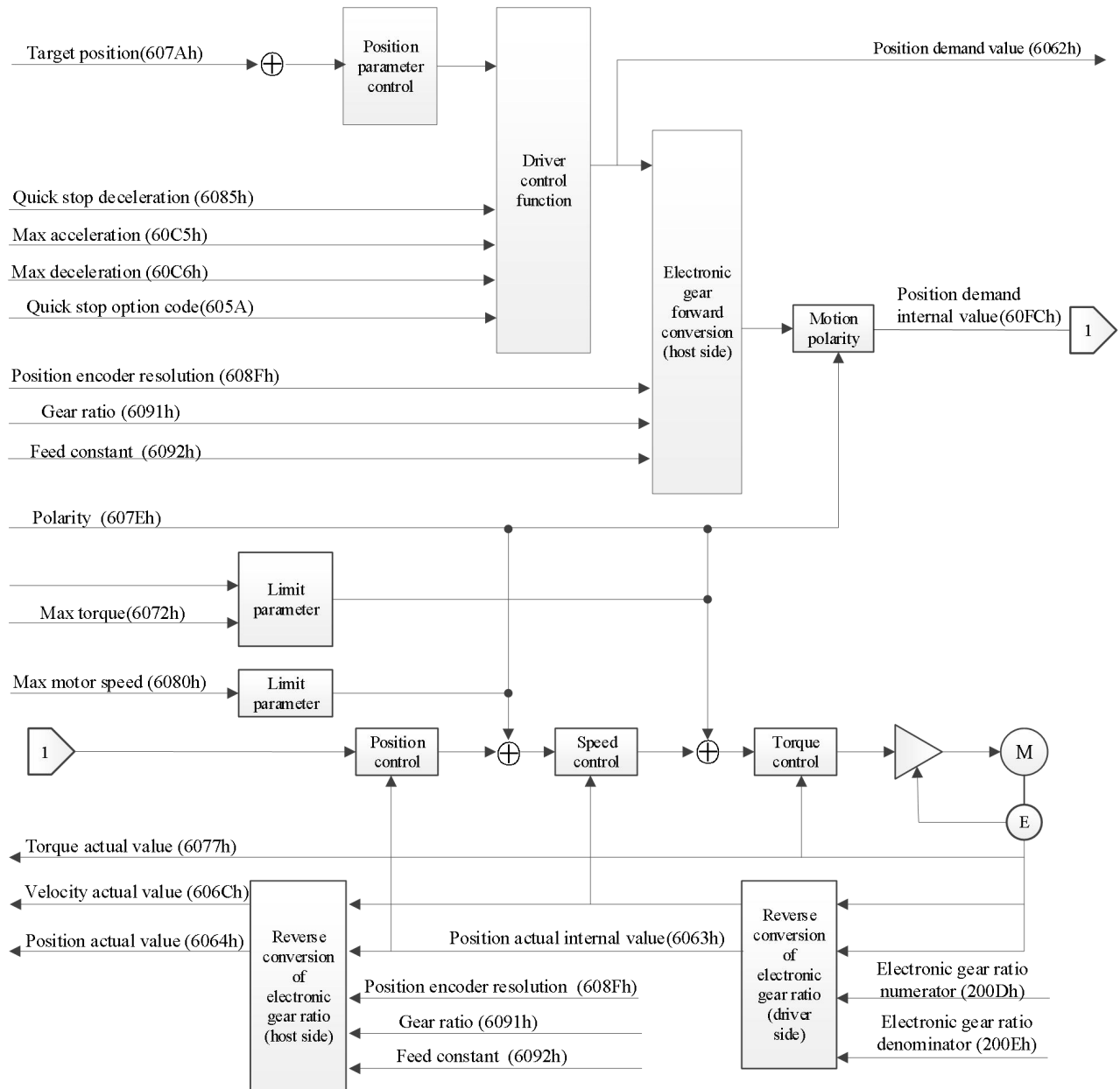

7.2.1 Related parameters

1) CSP Control mode associated object(Command · setting)

Index	Sub-index	Name	Unit	Range	Data type	Access	PDO
6040h	00h	Control word	-	0~65535	U16	rw	RxPDO

Other positions control common associated objects.

Index	Sub-index	Name	Unit	Range	Data type	Access	PDO
6072h	00h	Max torque	0.1%	0~65535	U16	rw	RxPDO
607Ah	00h	Target position	Command unit	-2147483648~2147483647	I32	rw	RxPDO
607Dh	-	Software position limit	-	-	-	-	-

Index	Sub-index	Name	Unit	Range	Data type	Access	PDO
	00h	Number of entries	-	2	U8	ro	No
	01h	Min position limit	Command unit	-2147483648~2147483647	I32	rw	RxPDO
	02h	Max position limit	Command unit	-2147483648~2147483647	I32	rw	RxPDO
607Fh	00h	Max profile velocity	Command unit/s	0~4294967295	U32	rw	RxPDO
6080h	00h	Max motor speed	r/min	0~4294967295	U32	rw	RxPDO
60B1h	00h	Velocity offset	Command unit/s	-2147483648~2147483647	I32	rw	RxPDO
60B2h	00h	Torque offset	0.1%	-32768~32767	I16	rw	RxPDO

Other related objects with common actions

Index	Sub-index	Name	Unit	Range	Data type	Access	PDO
605Ah	00h	Quick stop option code	-	0~7	I16	rw	NO
605Bh	00h	Shutdown option code	-	0~1	I16	rw	NO
605Ch	00h	Disable operation option code	-	0~1	I16	rw	NO
605Dh	00h	Halt option code	-	1~3	I16	rw	NO
605Eh	00h	Fault reaction option code	-	0~2	I16	rw	NO
607Dh	-	Software position limit	-	-	-	-	-
	00h	Number of entries	-	2	U8	ro	No
	01h	Min position limit	Command unit	-2147483648~2147483647	I32	rw	RxPDO
	02h	Max position limit	Command unit	-2147483648~2147483647	I32	rw	RxPDO
607Ch	00h	Home offset	Command unit	-2147483648~2147483647	I32	rw	RxPDO
607Eh	00h	Polarity	-	0~255	U8	rw	NO
6085h	00h	Quick stop deceleration	Command unit/s ²	0~4294967295	U32	rw	RxPDO
6086h	00h	Motion profile type	-	-32768~32767	I16	rw	RxPDO
608Fh	-	Position encoder resolution	-	-	-	-	-
	00h	Number of entries	-	2	U8	ro	No
	01h	Encoder increments	pulse	1~4294967295	U32	ro	No
	02h	Motor revolutions	r(motor)	1~4294967295	U32	ro	No
6091h	-	Gear ratio	-	-	-	-	-
	00h	Number of entries	-	2	U8	ro	No
	01h	Motor revolutions	r(motor)	1~4294967295	U32	ro	No
	02h	Shaft revolutions	r(shaft)	1~4294967295	U32	ro	No
6092h	-	Feed constant	-	-	-	-	-
	00h	Number of entries	-	2	U8	ro	No
	01h	Feed	Command unit	1~4294967295	U32	ro	No
	02h	Shaft revolutions	r(shaft)	1~4294967295	U32	ro	No
60B8h	00h	Touch probe function	-	0~65535	U16	rw	RxPDO

Controlword(6040h) < functions in CSP control mode >

Index	Sub-index	Name	Unit	Range	Data type	PDO	Op-mode
6040h	00h	Control word	0~65535	U16	Rw	RxPDO	All
		Set the control command for the servo driver such as PDS state conversion. Bit information					

Index	Sub-index	Name	Unit	Range	Data type	PDO	Op-mode		
		15	14	13	12	11	10	9	8
		R						om	h
		7	6	5	4	3	2	1	0
		fr	oms			eo	qs	ev	so
			r	r	r				
		r = reserved(not corresponding)			fr = fault reset				
		oms = operation mode specific (control mode is based on bit)			eo = enable operation				
		h = halt			qs = quick stop				
		so = switch on			ev = enable voltage				

CSP mode does not use oms bit.

2) realted CSP control mode (monitor)

Index	Sub-index	Name	Unit	Range	Data type	Access	PDO
6041h	00h	Statusword	-	0~65535	U16	ro	TxPDO

Other associated objects with common position control

Index	Sub-index	Name	Unit	Range	Data type	Access	PDO
6062h	00h	Position demand value	Command unit	-2147483648~2147483647	I32	ro	TxPDO
6063h	00h	Position actual internal value	pulse	-2147483648~2147483647	I32	ro	TxPDO
6064h	00h	Position actual value	Command unit	-2147483648~2147483647	I32	ro	TxPDO
6065h	00h	Position deviation too large threshold	Command unit	0~4294967295	U32	rw	RxPDO
6066h	00h	Following error time out	lms	0~65535	U16	rw	RxPDO
6067h	00h	Position window	Command unit	0~4294967295	U32	rw	RxPDO
6068h	00h	Position window time	lms	0~65535	U16	rw	RxPDO
606Ch	00h	Velocity actual value	Command unit/s	-2147483648~2147483647	I32	ro	TxPDO
6074h	00h	Torque value	0.1%	-32768~32767	I16	ro	TxPDO
6076h	00h	Motor rated torque	Mn·m	0~4294967295	U32	ro	TxPDO
6077h	00h	Torque actual value	0.1%	-32768~32767	I16	ro	TxPDO
60F4h	00h	Following error actual value	Command unit	-2147483648~2147483647	I32	ro	TxPDO
60FAh	00h	Control effort	Command unit/s	-2147483648~2147483647	I32	ro	TxPDO
60FCh	00h	Position demand internal value	pulse	-2147483648~2147483647	I32	ro	TxPDO

There are other related objects common to actions.

Index	Sub-index	Name	Unit	Range	Data type	Access	PDO
603Fh	00h	Error code	-	0~65535	U16	ro	TxPDO
60B9h	00h	Touch probe status	-	0~65535	U16	ro	TxPDO
60BAh	00h	Touch probe pos1 pos value	Command unit	-2147483648~2147483647	I32	ro	TxPDO
60BBh	00h	Touch probe pos1 neg value	Command unit	-2147483648~2147483647	I32	ro	TxPDO
60BCh	00h	Touch probe pos2 pos value	Command unit	-2147483648~2147483647	I32	ro	TxPDO
60BDh	00h	Touch probe pos2 neg value	Command unit	-2147483648~2147483647	I32	ro	TxPDO

Statusword (6041h) < functions in csp control mode >

Index	Sub-index	Name	Range	Data type	Access	PDO	Op-mode				
6041h	00h	Statusword	0~65535	U16	Ro	TxPDO	All				
Servo driver status											
Bit information											
15		14		13		12		11	10	9	8
r		oms				ila	oms	rm	r		
		Following error		Drive follow Command value				r			
7		6		5		4		3	2	1	0
w		sod		qs		Ve		f	oe	so	rsto
r = reserved(not corresponding)				w = warning							
sod = switch on disabled											
oms = operation mode specific (control mode is based on bit)				qs = quick stop				ve = voltage enabled			
ila = internal limit active				f = fault							
oe = operation enabled											
rm = remote				so = switched on							
rtso = ready to switch on											

bit13,12,10(operation mode specific):

Bit	Name	Value	Definition
10	Reserved	-	unuse
12	Set-point acknowledge	0	No action based on target location
		1	Perform actions based on target location
13	Following error	0	60F4h (Following error actual value) = (6062h (Position demand value) – 6064h (Position actual value)) is over the setting range of 6065h (Following error window) or 60F4h value is over the setting value of 6065h, not through the setting time of 6066h.
		1	60F4h (Following error actual value) is over the setting range of 6065h (Following error window) and above the setting time of 6066h (Following error time out)

Note: the "performing actions according to the target position" means that if all the following conditions are met:

- ◆ PDS status is operation enabled
- ◆ Not in deceleration process(Halt, Quick stop, Shutdown, Disable operation, Fault)
- ◆ Non Halt stop status

Actions in CSP control mode

- ◆ The cyclic position control mode is to generate the action model (track) through the host rather than the slave.
- ◆ The target position is the sum of 607Ah (target position) and 60B0h (position offset), which is understood as absolute position.
- ◆ The update (sending) of action command is that after the servo enable command (operation enabled command), please input after about 100 ms.
- ◆ 60C2h (interpolation time period), which means updating the period of 607AH (target position) and 60B0h (position offset). This value is set to the same period as 1C32h-02h (cycle time). The upper device (host) must update the target position through 60C2h (interpolation time period).
- ◆ The servo enable can be turned off. Please form 607Ah (target position) + 60B0h (position offset) to follow the host processing of 6064h (position actual value). If the motor moves by external force during the servo enable is turned off, if the servo enable is turned on next time, it is very dangerous because it needs to return to the input target position. In addition, when switching from control mode other than CSP control mode to CSP control mode, please also do the follow operation.

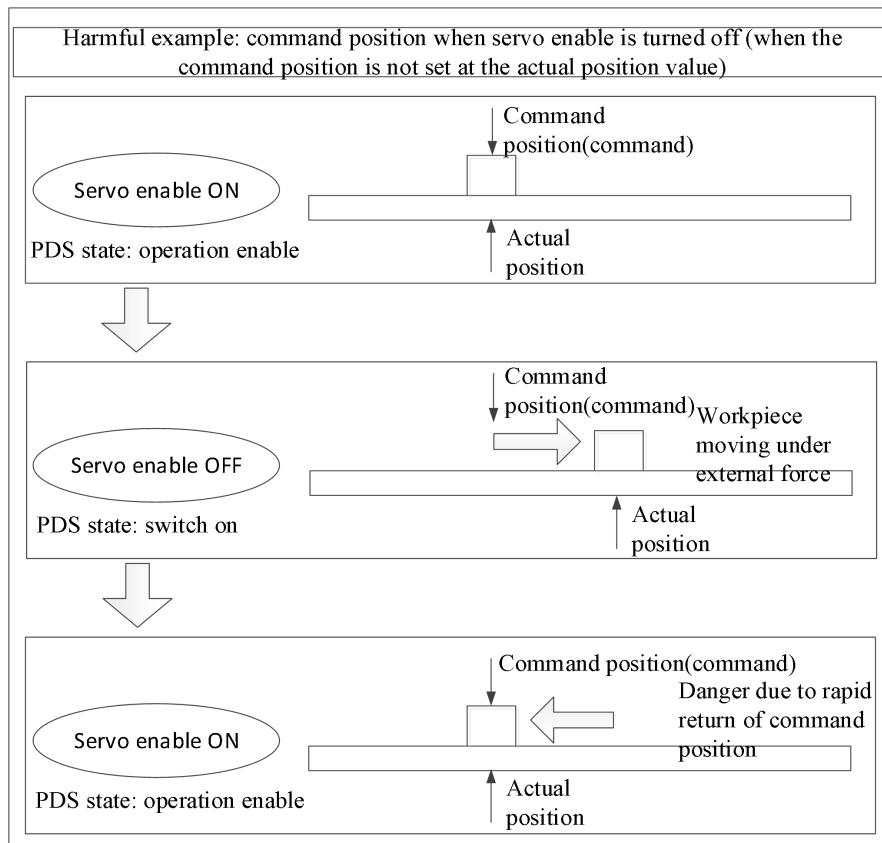

7.2.2 Common parameters

Register	Explanation	Unit
RXPDO[0x607A]	Target position, modification via IO mapping in CSP mode is invalid, which is controlled by NC module	Command unit
TXPDO[0x6064]	Position actual value(motor actual position)	Command unit
TXPDO[0x606C]	Velocity	Command unit/s
RXPDO[0x6060]	Set 8	-

7.3 CSV mode

CSV (periodic synchronous speed mode) enables the motor to run at a constant speed through the speed given by the upper computer.

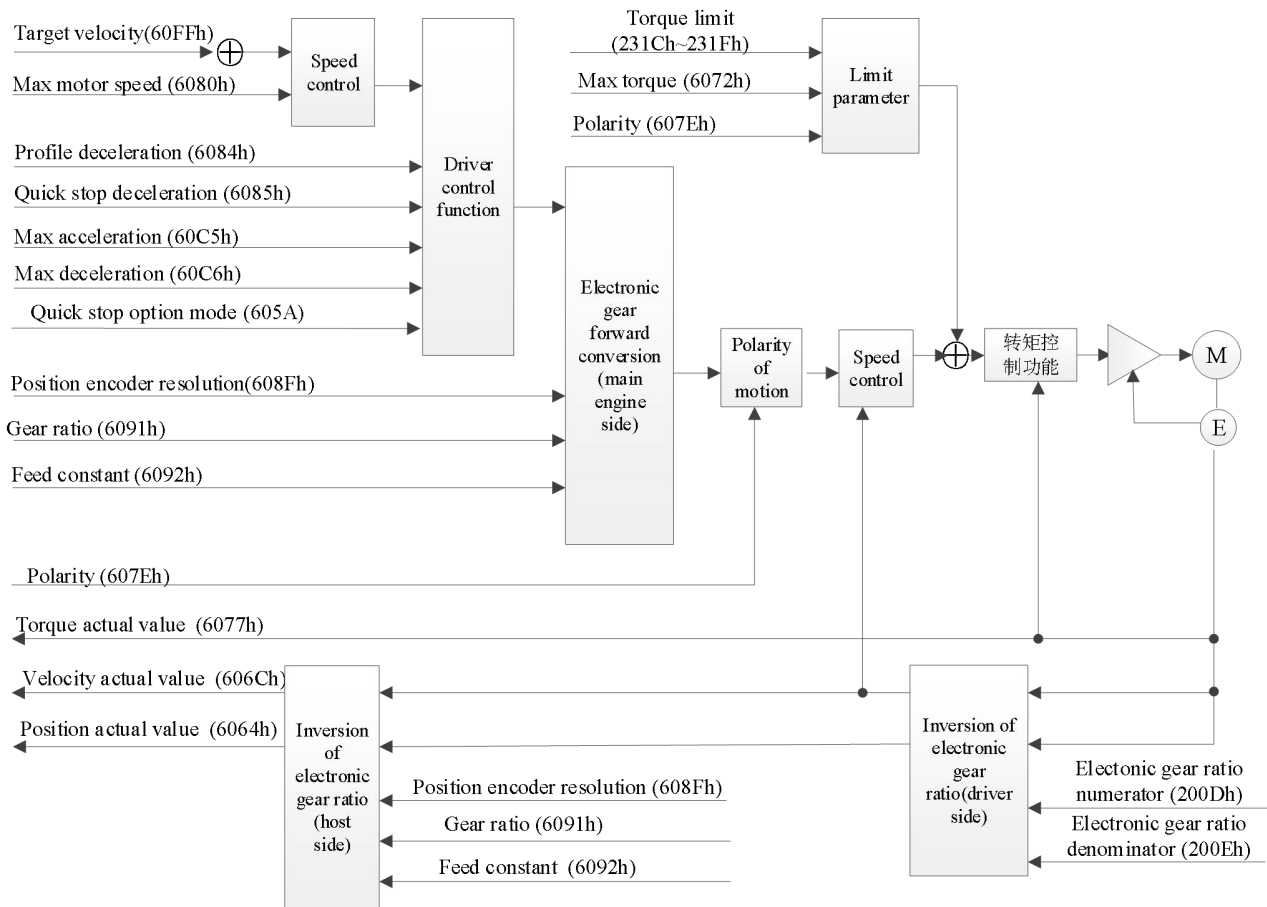

7.3.1 Related parameter

1) CSV Object associated with control mode (Command · setting)

Index	Sub-index	Name	Unit	Range	Data type	Access	PDO
6040h	00h	Control word	-	0~65535	U16	rw	RxPDO
607Fh	00h	Max profile velocity	Command unit/s	0~4294967295	U32	rw	RxPDO

Other objects that are commonly associated with speed control.

Index	Sub-index	Name	Unit	Range	Data type	Access	PDO
6072h	00h	Max torque	0.1%	0~65535	U16	rw	RxPDO
6080h	00h	Max motor speed	r/min	0~4294967295	U32	rw	RxPDO
60B1h	00h	Velocity offset	Command unit/s	-2147483648~2147483647	I32	rw	RxPDO
60B2h	00h	Torque offset	0.1%	-32768~32767	I16	rw	RxPDO
60FFh	00h	Target velocity	Command unit/s	0~4294967295	U32	rw	RxPDO

Other related objects with common actions.

Index	Sub-index	Name	Unit	Range	Data type	Access	PDO
605Ah	00h	Quick stop option code	-	0~7	I16	rw	NO
605Bh	00h	Shutdown option code	-	0~1	I16	rw	NO
605Ch	00h	Disable operation option code	-	0~1	I16	rw	NO

Index	Sub-index	Name	Unit	Range	Data type	Access	PDO
605Dh	00h	Halt option code	-	1~3	I16	rw	NO
605Eh	00h	Fault reaction option code	-	0~2	I16	rw	NO
607Bh	-	Position range limit	-	-	-	-	-
	00h	Number of entries	-	2	U8	ro	NO
	01h	Min position limit	Command unit	-2147483648~2147483647	I32	rw	RxPDO
	02h	Max position limit	Command unit	-2147483648~2147483647	I32	rw	RxPDO
607Ch	00h	Home offset	Command unit	-2147483648~2147483647	I32	rw	RxPDO
607Eh	00h	Polarity	-	0~255	U8	rw	NO
6085h	00h	Quick stop deceleration	Command unit/s ²	0~4294967295	U32	rw	RxPDO
6086h	00h	Motion profile type	-	-32768~32767	I16	rw	RxPDO
608Fh	-	Position encoder resolution	-	-	-	-	-
	00h	Number of entries	-	2	U8	ro	NO
	01h	Encoder increments	pulse	1~4294967295	U32	ro	NO
	02h	Motor revolutions	r(motor)	1~4294967295	U32	ro	NO
6091h	-	Gear ratio	-	-	-	-	-
	00h	Number of entries	-	2	U8	ro	NO
	01h	Motor revolutions	r(motor)	1~4294967295	U32	ro	NO
	02h	Shaft revolutions	r(shaft)	1~4294967295	U32	ro	NO
6092h	-	Feed constant	-	-	-	-	-
	00h	Number of entries	-	2	U8	ro	NO
	01h	Feed	Command unit	1~4294967295	U32	ro	NO
	02h	Shaft revolutions	r(shaft)	1~4294967295	U32	ro	NO
60B8h	00h	Touch probe function	-	0~65535	U16	rw	RxPDO

Controlword(6040h) < Function in csv control mode >

Index	Sub-index	Name	Unit	Range	Data type	Access	PDO																																									
6040h	00h	Controlword	0~65535	U16	rw	RxPDO	All																																									
		Set the control command for the servo driver such as PDS state conversion. Bit information																																														
		<table border="1" style="width:100%; border-collapse: collapse;"> <tr> <td style="width:12.5%;">15</td> <td style="width:12.5%;">14</td> <td style="width:12.5%;">13</td> <td style="width:12.5%;">12</td> <td style="width:12.5%;">11</td> <td style="width:12.5%;">10</td> <td style="width:12.5%;">9</td> <td style="width:12.5%;">8</td> </tr> <tr> <td colspan="6" style="text-align:center;">R</td> <td style="text-align:center;">om</td> <td style="text-align:center;">h</td> </tr> <tr> <td style="text-align:center;">7</td> <td style="text-align:center;">6</td> <td style="text-align:center;">5</td> <td style="text-align:center;">4</td> <td style="text-align:center;">3</td> <td style="text-align:center;">2</td> <td style="text-align:center;">1</td> <td style="text-align:center;">0</td> </tr> <tr> <td style="text-align:center;">fr</td> <td colspan="3" style="text-align:center;">oms</td> <td style="text-align:center;">eo</td> <td style="text-align:center;">qs</td> <td style="text-align:center;">ev</td> <td style="text-align:center;">so</td> </tr> <tr> <td></td> <td style="text-align:center;">r</td> <td style="text-align:center;">r</td> <td style="text-align:center;">r</td> <td></td> <td></td> <td></td> <td></td> </tr> </table>							15	14	13	12	11	10	9	8	R						om	h	7	6	5	4	3	2	1	0	fr	oms			eo	qs	ev	so		r	r	r				
		15	14	13	12	11	10	9	8																																							
		R						om	h																																							
		7	6	5	4	3	2	1	0																																							
		fr	oms			eo	qs	ev	so																																							
			r	r	r																																											
		r = reserved(not corresponding)				fr = fault reset																																										
		oms = operation mode specific (control mode is based on bit)				eo = enable operation																																										
h = halt				qs = quick stop																																												
so = switch on				ev = enable voltage																																												

Csv mode doesn't use oms bit.

2)Objects associated with CSV control mode (monitoring)

Index	Sub-index	Name	Unit	Range	Data type	Access	PDO
6041h	00h	Statusword	-	0~65535	U16	ro	TxPDO

Other related objects common to speed control.

Index	Sub-index	Name	Unit	Range	Data type	Access	PDO
6063h	00h	Position actual internal value	pulse	-2147483648~2147483647	I32	ro	TxPDO
6064h	00h	Position actual value	Command	-2147483648~	I32	ro	TxPDO

Index	Sub-index	Name	Unit	Range	Data type	Access	PDO
			unit	2147483647			
606Bh	00h	Velocity demand value	Command unit/s	-2147483648~2147483647	I32	ro	TxPDO
606Ch	00h	Velocity actual value	Command unit/s	-2147483648~2147483647	I32	ro	TxPDO
6074h	00h	Torque demand	0.1%	-32768~32767	I16	ro	TxPDO
6076h	00h	Motor rated torque	Mn·m	0~4294967295	U32	ro	TxPDO
6077h	00h	Torque actual value	0.1%	-32768~32767	I16	ro	TxPDO

Other associated objects that share the same mode.

Index	Sub-index	Name	Unit	Range	Data type	Access	PDO
603Fh	00h	Error Code	-	0~65535	U16	ro	TxPDO
60B9h	00h	Touch probe status	-	0~65535	U16	ro	TxPDO
60BAh	00h	Touch probe pos1 pos value	Command unit	-2147483648~2147483647	I32	ro	TxPDO
60BBh	00h	Touch probe pos1 neg value	Command unit	-2147483648~2147483647	I32	ro	TxPDO
60BCh	00h	Touch probe pos2 pos value	Command unit	-2147483648~2147483647	I32	ro	TxPDO
60BDh	00h	Touch probe pos2 neg value	Command unit	-2147483648~2147483647	I32	ro	TxPDO

Statusword (6041h) < Function of csv control mode >

Index	Sub-index	Name	Unit	Range	Data type	Access	PDO																																												
6041h	00h	Status word	0~65535	U16	ro	TxPDO	All																																												
Servo driver status. Bit information																																																			
<table border="1" style="width:100%; border-collapse: collapse;"> <thead> <tr> <th>15</th> <th>14</th> <th>13</th> <th>12</th> <th>11</th> <th>10</th> <th>9</th> <th>8</th> </tr> </thead> <tbody> <tr> <td colspan="2" style="text-align: center;">r</td> <td colspan="4" style="text-align: center;">oms</td> <td style="text-align: center;">ila</td> <td style="text-align: center;">oms</td> <td style="text-align: center;">rm</td> <td style="text-align: center;">r</td> </tr> <tr> <td colspan="2"></td> <td style="text-align: center;">r</td> <td colspan="4" style="text-align: center;">follow drive command vaule</td> <td style="text-align: center;">r</td> <td colspan="2"></td> </tr> <tr> <th>7</th> <th>6</th> <th>5</th> <th>4</th> <th>3</th> <th>2</th> <th>1</th> <th>0</th> </tr> <tr> <td style="text-align: center;">w</td> <td style="text-align: center;">sod</td> <td style="text-align: center;">qs</td> <td style="text-align: center;">ve</td> <td style="text-align: center;">f</td> <td style="text-align: center;">oe</td> <td style="text-align: center;">so</td> <td style="text-align: center;">rsto</td> </tr> </tbody> </table>								15	14	13	12	11	10	9	8	r		oms				ila	oms	rm	r			r	follow drive command vaule				r			7	6	5	4	3	2	1	0	w	sod	qs	ve	f	oe	so	rsto
15	14	13	12	11	10	9	8																																												
r		oms				ila	oms	rm	r																																										
		r	follow drive command vaule				r																																												
7	6	5	4	3	2	1	0																																												
w	sod	qs	ve	f	oe	so	rsto																																												
r = reserved(not corresponding) w = warning sod = switch on disabled oms = operation mode specific qs = quick stop (control mode is based on bit) ve = voltage enabled ila = internal limit active f = fault oe = operation enabled rm = remote so = switched on rtso = ready to switch on																																																			

bit13,12,10(operation mode specific):

Bit	Name	Value	Definition
10	Reserved	-	Unuse
12	Reserved	0	Action not performed according to target speed
		1	Perform the action according to the target speed
13	Reserved	-	Unuse

The "performing actions according to target speed" should meet the following conditions:

- ◆ The PDS status is operation enabled
- ◆ Not in deceleration processing (halt, quickstop, shutdown, disable operation, falut)
- ◆ It is not a halt state.
- ◆ The torque limit does not occur

Actions in CSV control mode

- ◆ In the cyclic speed control mode, the motion model (trajectory) is generated not on the slave but on the master.
- ◆ The target speed is 60FFh (target velocity)
- ◆ The update (sending) of action command is that after the operation enabled command, please input it after about 100 ms.
- ◆ 60C2h (interpolation time period) means the period of updating 60FFh (target velocity) and 60B1h (velocity offset). This value is set to the same period as 1C32h-02h (cycle time).
- ◆ As monitoring information, provide 606Ch (velocity actual value), etc.
- ◆ The 60FFh (target velocity) value is limited by 6080h (max motor speed).

7.3.2 Common parameters

Register	Explanation	Unit
RXPDO[0x60FF]	Target velocity	Command unit/s
TXPDO[0x6064]	Position actual value	Command unit
TXPDO[0x606C]	Velocity actual value	Command unit/s
RXPDO[0x6080]	Max motor speed, which can be modified through COE-Online	r/min
RXPDO[0x6060]	Control mode is CSV (Periodic Synchronous Speed Mode), set its value to 9	-

7.4 CST mode

CST (periodic synchronous torque mode) allows the motor to run at a constant torque through the torque given by the upper computer.

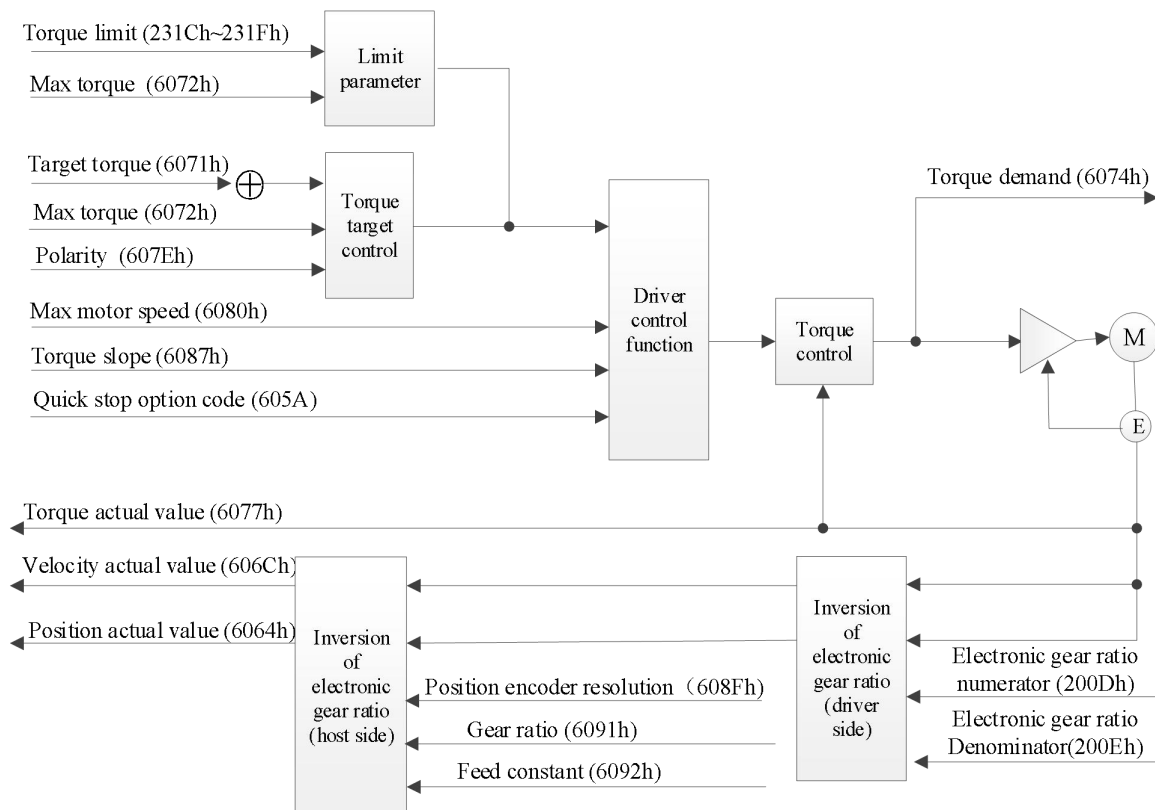

7.4.1 Related parameter

1) Objects associated with CST control mode (Command · setting)

Index	Sub-index	Name	Unit	Range	Data type	Access	PDO
6040h	00h	Controlword	-	0~65535	U16	rw	RxPDO

Other related objects with common torque control.

Index	Sub-index	Name	Unit	Range	Data type	Access	PDO
6071h	00h	Target torque	0.1%	-32768~32767	I16	rw	RxPDO
6072h	00h	Max torque	0.1%	0~65535	U16	rw	RxPDO
6080h	00h	Max motor speed	r/min	0~4294967295	U32	rw	RxPDO
6087h	00h	Torque slope	0.1%/S	0~4294967295	U32	rw	RxPDO
60B2h	00h	Torque offset	0.1%	-32768~32767	I16	rw	RxPDO

Other related objects with common actions.

Index	Sub-index	Name	Unit	Range	Data type	Access	PDO
605Ah	00h	Quick stop option code	-	0~7	I16	rw	NO
605Bh	00h	Shutdown option code	-	0~1	I16	rw	NO
605Ch	00h	Disable operation option code	-	0~1	I16	rw	NO
605Dh	00h	Halt option code	-	1~3	I16	rw	NO
605Eh	00h	Fault reaction option code	-	0~2	I16	rw	NO
607Bh	-	Position range limit	-	-	-	-	-
	00h	Number of entries	-	2	U8	ro	NO

Index	Sub-index	Name	Unit	Range	Data type	Access	PDO
	01h	Min position limit	Command unit	-2147483648 ~ 2147483647	I32	rw	RxPDO
	02h	Max position limit	Command unit	-2147483648 ~ 2147483647	I32	rw	RxPDO
607Ch	00h	Home offset	Command unit	-2147483648 ~ 2147483647	I32	rw	RxPDO
607Eh	00h	Polarity	-	0~255	U8	rw	NO
6085h	00h	Quick stop deceleration	Command unit / s ²	0~429496729 5	U32	rw	RxPDO
6086h	00h	Motion profile type	-	-32768~3276 7	I16	rw	RxPDO
608Fh	-	Position encoder resolution	-	-	-	-	-
	00h	Number of entries	-	2	U8	ro	NO
	01h	Encoder increments	pulse	1~429496729 5	U32	ro	NO
	02h	Motor revolutions	r(motor)	1~429496729 5	U32	ro	NO
6091h	-	Gear ratio	-	-	-	-	-
	00h	Number of entries	-	2	U8	ro	NO
	01h	Motor revolutions	r(motor)	1~429496729 5	U32	ro	NO
	02h	Shaft revolutions	r(shaft)	1~429496729 5	U32	ro	NO
6092h	-	Feed constant	-	-	-	-	-
	00h	Number of entries	-	2	U8	ro	NO
	01h	Feed	Command unit	1~429496729 5	U32	ro	NO
	02h	Shaft revolutions	r(shaft)	1~429496729 5	U32	ro	NO
60B8h	00h	Touch probe function	-	0~65535	U16	rw	RxPDO

Control word (6040h) <function in cst control mode>

Index	Sub-index	Name	Range	Data type	Access	PDO	Op-mode																																										
6040h	00h	Controlword	0~65535	U16	Rw	RxPDO	All																																										
		Set the control command to the servo driver such as PDS state conversion. Bit information																																															
		<table border="1" style="width: 100%; text-align: center;"> <tr> <td>15</td><td>14</td><td>13</td><td>12</td><td>11</td><td>10</td><td>9</td><td>8</td> </tr> <tr> <td colspan="6">r</td> <td>om</td><td>h</td> </tr> <tr> <td>7</td><td>6</td><td>5</td><td>4</td><td>3</td><td>2</td><td>1</td><td>0</td> </tr> <tr> <td>fr</td><td colspan="3">oms</td><td>eo</td><td>qs</td><td>ev</td><td>so</td> </tr> <tr> <td></td><td>r</td><td>r</td><td>r</td><td></td><td></td><td></td><td></td> </tr> </table>								15	14	13	12	11	10	9	8	r						om	h	7	6	5	4	3	2	1	0	fr	oms			eo	qs	ev	so		r	r	r				
		15	14	13	12	11	10	9	8																																								
r						om	h																																										
7	6	5	4	3	2	1	0																																										
fr	oms			eo	qs	ev	so																																										
	r	r	r																																														
r = reserved(not corresponding) oms = operation mode specific (control mode is based on bit) h = halt so = switch on				fr = fault reset eo = enable operation qs = quick stop ev = enable voltage																																													

Cst mode doesn't use oms bit.

2) Objects associated with CST torque control (monitoring)

Index	Sub-index	Name	Units	Range	Data type	Access	PDO
6041h	00h	Statusword	-	0~65535	U16	ro	TxPDO
6073h	00h	Max current	0.1%	0~65535	U16	ro	NO

Other objects commonly associated with torque control (monitoring)

Index	Sub-index	Name	Units	Range	Data type	Access	PDO
6063h	00h	Position actual internal value	pulse	-2147483648~2147483647	I32	ro	TxPDO
6064h	00h	Position actual value	Command unit	-2147483648~2147483647	I32	ro	TxPDO
606Ch	00h	Velocity actual value	Command unit/s	-2147483648~2147483647	I32	ro	TxPDO
6074h	00h	Torque demand	0.1%	-32768~32767	I16	ro	TxPDO
6075h	00h	Motor rated current	1mA	0~4294967295	U32	ro	TxPDO
6076h	00h	Motor rated torque	Mn·m	0~4294967295	U32	ro	TxPDO
6077h	00h	Torque actual value	0.1%	-32768~32767	I16	ro	TxPDO
6078h	00h	Current actual value	0.1%	-32768~32767	I16	ro	TxPDO

Other associated objects that share the same mode.

Index	Sub-index	Name	Units	Range	Data type	Access	PDO
603Fh	00h	Error Code	-	0~65535	U16	ro	TxPDO
60B9h	00h	Touch probe status	-	0~65535	U16	ro	TxPDO
60BAh	00h	Touch probe pos1 pos value	Command unit	-2147483648~2147483647	I32	ro	TxPDO
60BBh	00h	Touch probe pos1 neg value	Command unit	-2147483648~2147483647	I32	ro	TxPDO
60BCh	00h	Touch probe pos2 pos value	Command unit	-2147483648~2147483647	I32	ro	TxPDO
60BDh	00h	Touch probe pos2 neg value	Command unit	-2147483648~2147483647	I32	ro	TxPDO

Statusword (6041h) < functions in tq control mode >

Index	Sub-Index	Name/Description	Range	DateType	Access	PDO	Op-mode																																								
6041h	00h	Statusword	0~65535	U16	ro	TxPDO	All																																								
Servo driver status. Bit information <table border="1" style="width: 100%; border-collapse: collapse;"> <thead> <tr> <th style="width: 4.1%;">15</th> <th style="width: 4.1%;">14</th> <th style="width: 4.1%;">13</th> <th style="width: 4.1%;">12</th> <th style="width: 4.1%;">11</th> <th style="width: 4.1%;">10</th> <th style="width: 4.1%;">9</th> <th style="width: 4.1%;">8</th> </tr> </thead> <tbody> <tr> <td style="text-align: center;">r</td> <td colspan="3" style="text-align: center;">oms</td> <td rowspan="2" style="text-align: center;">ila</td> <td style="text-align: center;">oms</td> <td style="text-align: center;">rm</td> <td style="text-align: center;">r</td> </tr> <tr> <td colspan="2" style="text-align: center;">r</td> <td colspan="3" style="text-align: center;">Drive following command vaule</td> <td style="text-align: center;">r</td> <td></td> <td></td> </tr> <tr> <th style="width: 4.1%;">7</th> <th style="width: 4.1%;">6</th> <th style="width: 4.1%;">5</th> <th style="width: 4.1%;">4</th> <th style="width: 4.1%;">3</th> <th style="width: 4.1%;">2</th> <th style="width: 4.1%;">1</th> <th style="width: 4.1%;">0</th> </tr> <tr> <td style="text-align: center;">w</td> <td style="text-align: center;">sod</td> <td style="text-align: center;">qs</td> <td style="text-align: center;">ve</td> <td style="text-align: center;">f</td> <td style="text-align: center;">oe</td> <td style="text-align: center;">so</td> <td style="text-align: center;">rsto</td> </tr> </tbody> </table> r = reserved(not corresponding) w = warning sod = switch on disabled oms = operation mode specific qs = quick stop (control mode is based on bit) ve = vantage enabled ila = internal limit active f = fault oe = operation enabled so = switched on rm = remote rtso = ready to switch on								15	14	13	12	11	10	9	8	r	oms			ila	oms	rm	r	r		Drive following command vaule			r			7	6	5	4	3	2	1	0	w	sod	qs	ve	f	oe	so	rsto
15	14	13	12	11	10	9	8																																								
r	oms			ila	oms	rm	r																																								
r		Drive following command vaule			r																																										
7	6	5	4	3	2	1	0																																								
w	sod	qs	ve	f	oe	so	rsto																																								

bit13,12,10(operation mode specific):

Bit	Name	Value	Definition
10	Reserved	-	Unuse
12	Torque	0	Action not performed according to target torque
		1	Perform the action according to the target torque
13	Reserved	-	Unuse

Performing actions according to target torque should meet the following conditions:

- ♦ The PDS status is operation enabled

- ◆ not in deceleration processing (halt, quickstop, shutdown, disable operation, falut)
- ◆ It is not a halt state

Actions of CST control mode

- ◆ In the cyclic torque control mode, the mode profile generation is not in the slave but in the host.
- ◆ The target torque is 6071h (target torque)
- ◆ The torque feedforward is 60B2h (torque offset), which is not supported temporarily.
- ◆ The update (sending) of action command, after the servo is on, please input after about 100ms.
- ◆ 60C2h (interpolation time period) means updating the period of 6071h (target torque) and 60B2h (torque offset). This value is set to the same period as 1C32h-02h (cycle time).
- ◆ As monitoring information, provide 6077h (torque actual value), etc.
- ◆ The 6071h (target torque) value is limited by 6072h (max torque), 2312h (P3-28), 2313h (P3-29), the minimum value.
- ◆ The speed limit is 6080h (max motor speed).

7.4.2 Common parameters

Register	Explanation	Unit
RXPDO[0x6071]	Target torque	0.1%
TXPDO[0x6064]	Position actual value	Command unit
TXPDO[0x606C]	Velocity actual value	Command unit /s
TXPDO[0x6077]	Torque actual value	0.1%
RXPDO[0x6080]	Max motor speed	r/min
RXPDO[0x6060]	Control mode is CST (Periodic Synchronous Torque Mode), set its value to 10	-

7.5 HM mode

HM mode (i.e. home mode) is used for initialization of the slave station position. An origin reset method is a position control mode that specifies an operation speed and generates a position command inside the servo driver to perform an origin reset operation. If it is used in the incremental mode, after the control power is put into operation, it is necessary to perform the zero point reset action before performing the position positioning work.

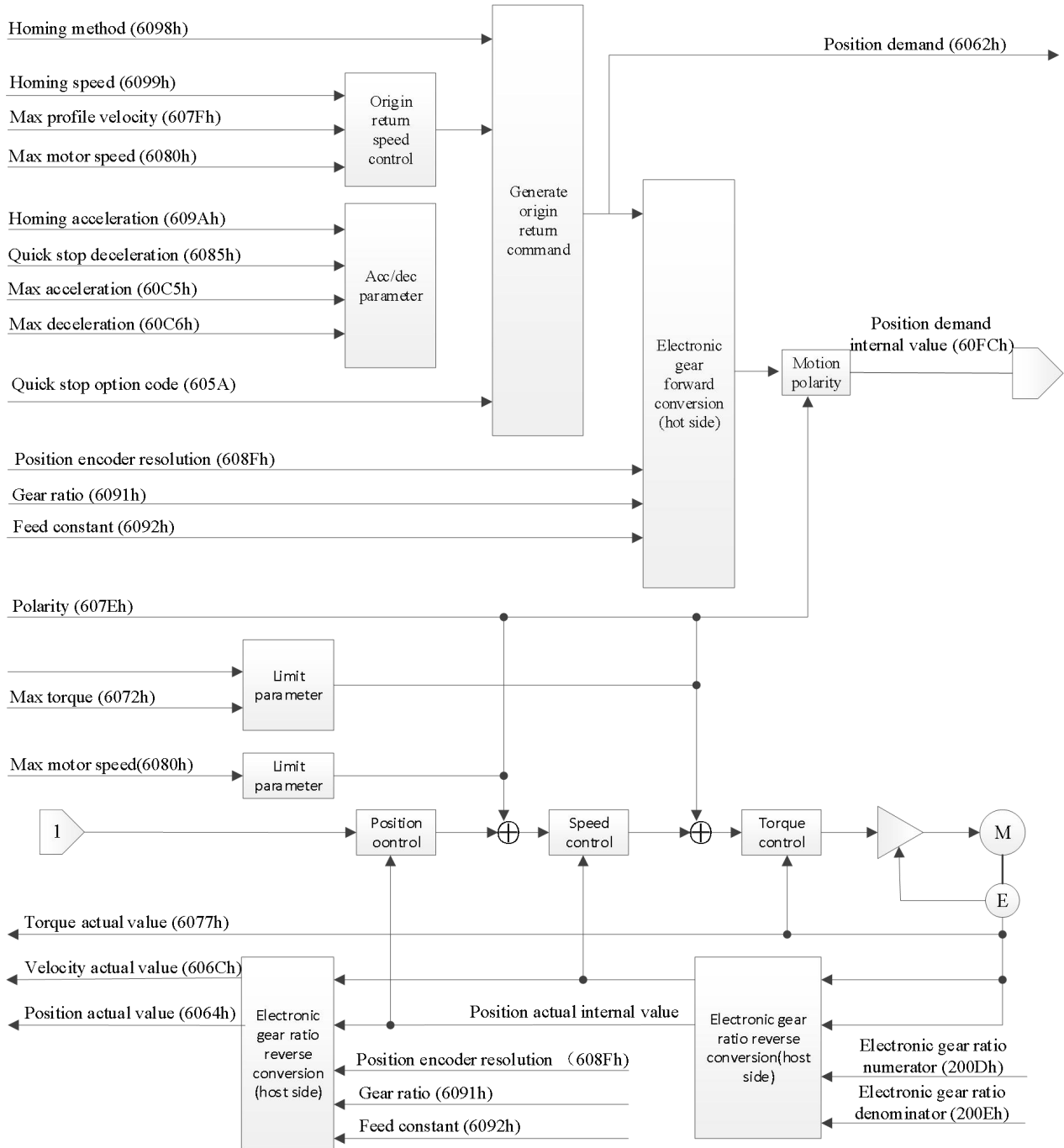

7.5.1 Related parameter

1) Related object of HM control mode(Command · setting)

Index	Sub-index	Name	Units	Range	Data type	Access	PDO
6040h	00h	ControlWord	-	0~65535	U16	rw	RxPDO
6098h	00h	Homing method	-	-128~127	I8	rw	RxPDO
6099h	-	Homing speeds	-	-	-	-	-
	00h	Number of entries	-	2	U8	ro	NO
	01h	Speed during search for switch	Command unit/s	0~4294967295	U32	rw	RxPDO
	02h	Speed during search for zero	Command unit/s	0~4294967295	U32	rw	RxPDO
609Ah	00h	Homing acceleration	Command unit/s ²	0~4294967295	U32	rw	RxPDO

Other related objects with common position control

Index	Sub-index	Name	Units	Range	Data type	Access	PDO
6072h	00h	Max torque	0.1%	0~65535	U16	rw	RxPDO
607Fh	00h	Max profile velocity	Command unit/s	0~4294967295	U32	rw	RxPDO
6080h	00h	Max motor speed	r/min	0~4294967295	U32	rw	RxPDO
60B1h	00h	Velocity offset	Command unit/s	-2147483648~2147483647	I32	rw	RxPDO
60B2h	00h	Torque offset	0.1%	-32768~32767	I16	rw	RxPDO
60C5h	00h	Max acceleration	Command unit/ s ²	0~4294967295	U32	rw	RxPDO
60C6h	00h	Max deceleration	Command unit/ s ²	0~4294967295	U32	rw	RxPDO

Other related objects with common actions

Index	Sub-index	Name	Units	Range	Data type	Access	PDO
605Ah	00h	Quick stop option code	-	0~7	I16	rw	NO
605Bh	00h	Shutdown option code	-	0~1	I16	rw	NO
605Ch	00h	Disable operation option code	-	0~1	I16	rw	NO
605Dh	00h	Halt option code	-	1~3	I16	rw	NO
605Eh	00h	Fault reaction option code	-	0~2	I16	rw	NO
607Dh	-	Software position limit	-	-	-	-	-
	00h	Number of entries	-	2	U8	ro	NO
	01h	Min position limit	Command unit	-2147483648~2147483647	I32	rw	RxPDO
	02h	Max position limit	Command unit	-2147483648~2147483647	I32	rw	RxPDO
607Ch	00h	Home offset	Command unit	-2147483648~2147483647	I32	rw	RxPDO
607Eh	00h	Polarity	-	0~255	U8	rw	NO
6085h	00h	Quick stop deceleration	Command unit/s ²	0~4294967295	U32	rw	RxPDO
6086h	00h	Motion profile type	-	-32768~32767	I16	rw	RxPDO
608Fh	-	Position encoder resolution	-	-	-	-	-
	00h	Number of entries	-	2	U8	ro	NO
	01h	Encoder increments	Pulse	1~4294967295	U32	ro	NO

Index	Sub-index	Name	Units	Range	Data type	Access	PDO
	02h	Motor revolutions	r(motor)	1~4294967295	U32	ro	NO
6091h	-	Gear ratio	-	-	-	-	-
	00h	Number of entries	-	2	U8	ro	NO
	01h	Motor revolutions	r(motor)	1~4294967295	U32	ro	NO
	02h	Shaft revolutions	r(shaft)	1~4294967295	U32	ro	NO
6092h	-	Feed constant	-	-	-	-	-
	00h	Number of entries	-	2	U8	ro	NO
	01h	Set Feed	Command unit	1~4294967295	U32	ro	NO
	02h	Shaft revolutions	r(shaft)	1~4294967295	U32	ro	NO
60B8h	00h	Touch probe function	-	0~65535	U16	rw	RxPDO

Controlword (6040h) < Functions in HM control mode >

Index	Sub-index	Name	Range	Data type	Access	PDO	Op-mode																																								
6040h	00h	Control word	0~65535	U16	Rw	RxPDO	All																																								
Set the control command to the servo driver such as PDS state conversion. Bit information																																															
<table border="1" style="width: 100%; border-collapse: collapse;"> <tr> <td style="width: 12.5%;">15</td> <td style="width: 12.5%;">14</td> <td style="width: 12.5%;">13</td> <td style="width: 12.5%;">12</td> <td style="width: 12.5%;">11</td> <td style="width: 12.5%;">10</td> <td style="width: 12.5%;">9</td> <td style="width: 12.5%;">8</td> </tr> <tr> <td colspan="6" style="text-align: center;">r</td> <td style="text-align: center;">oms</td> <td style="text-align: center;">h</td> </tr> <tr> <td style="width: 12.5%;">7</td> <td style="width: 12.5%;">6</td> <td style="width: 12.5%;">5</td> <td style="width: 12.5%;">4</td> <td style="width: 12.5%;">3</td> <td style="width: 12.5%;">2</td> <td style="width: 12.5%;">1</td> <td style="width: 12.5%;">0</td> </tr> <tr> <td style="text-align: center;">Fr</td> <td colspan="3" style="text-align: center;">oms</td> <td style="text-align: center;">eo</td> <td style="text-align: center;">qs</td> <td style="text-align: center;">ev</td> <td style="text-align: center;">so</td> </tr> <tr> <td></td> <td style="text-align: center;">r</td> <td style="text-align: center;">r</td> <td colspan="2" style="text-align: center;">start homing</td> <td></td> <td></td> <td></td> </tr> </table>								15	14	13	12	11	10	9	8	r						oms	h	7	6	5	4	3	2	1	0	Fr	oms			eo	qs	ev	so		r	r	start homing				
15	14	13	12	11	10	9	8																																								
r						oms	h																																								
7	6	5	4	3	2	1	0																																								
Fr	oms			eo	qs	ev	so																																								
	r	r	start homing																																												
<p>r = reserved(not corresponding) fr = fault reset oms = operation mode specific eo = enable operation (control mode is based on bit) qs = quick stop h = halt ev = enable voltage so = switch on</p>																																															

bit9,6-4(operation mode specific):

Bit	Name	Value	Definition
4	start homing	0 -> 1	Start the origin point reset action
5	(reserved)	-	not used
6	(reserved)	-	not used
9	(reserved)	-	not used

Through the opening of bit4 (start homing) of 6040h (control word), obtain the parameters (timing method, speed, acceleration and deceleration, etc.) associated with the origin reset position control mode (HM), and start the action.

In addition, in the origin reset action, even if a new origin reset action (bit4 of 6040h is started again), the new origin reset action is ignored.

Homing method(6098h)

Index	Sub-index	Name	Range	Data type	Access	PDO	Op-mode	
6098h	00h	Homing method	-128~127	I8	rw	RxPDO	All	
		Set the zero point reset method						
		Value	Definition					
		0	No homing method assigned					
		1	-Ve LS & Index Pulse					
		2	+Ve LS & Index Pulse					
		3	+Ve HS & Index Pulse direction reversal					
		4	+Ve HS & Index Pulse no direction changed					
		5	-Ve HS & Index Pulse direction reversal					
		6	-Ve HS & Index Pulse no direction changed					
		7	On +Ve HS -Index Pulse					
		8	On +Ve HS +Index Pulse					
		9	After +Ve HS reverse +Index Pulse					
		10	After +Ve HS +Index Pulse					
		11	On -Ve HS -Index Pulse					
		12	On -Ve HS +Index Pulse					
		13	After -Ve HS reverse +Index Pulse					
		14	After -Ve HS +Index Pulse					
		15	Reserved					
		16	Reserved					
		17	Same as 1 without Index pulse					
		18	Same as 2 without Index pulse					
		19	Same as 3 without Index pulse					
		20	Same as 4 without Index pulse					
		21	Same as 5 without Index pulse					
		22	Same as 6 without Index pulse					
		23	Same as 7 without Index pulse					
		24	Same as 8 without Index pulse					
		25	Same as 9 without Index pulse					
		26	Same as 10 without Index pulse					
		27	Same as 11 without Index pulse					
		28	Same as 12 without Index pulse					
		29	Same as 13 without Index pulse					
		30	Same as 14 without Index pulse					
		33	On Index Pulse +Ve direction					
		34	On Index Pulse -Ve direction					
		35	Current position = home					
37	Current position = home							
		+Ve: positive	LS: Limit switch					
		-Ve: negative	HS: Home switch					

Homing speeds(6099h)

Index	Sub-index	Name	Range	Data type	Access	PDO	Op-mode
6099h	-	Homing speeds	-	-	-	-	-
		Set the speed in the home reset position control mode (HM).					
	00h	Number of entries	2	U8	ro	NO	HM
		Sub-Index number of 6099h (Homing speeds)					
	01h	Speed during search	0~4294967295	U32	rw	RxPDO	HM
		Set the speed of the action to be detected by the switch signal. The maximum value is limited by any smaller one of the internal processing of 6080h (max					

		motor speed) and 2147483647.					
	02h	Speed during search for zero	0~4294967295	U32	rw	RxPDO	HM
		Set the action speed to zero point detection. If the edge of the switch signal is used as the origin detection position, in order to reduce the detection error, please set a value as small as possible. The maximum value is limited by the smaller side of the internal processing of 6080h (max motor speed) and 2147483647.					

Homing acceleration (609Ah)

Index	Sub-index	Name	Range	Data type	Access	PDO	Op-mode
609Ah	00h	Homing acceleration	0~4294967295	U32	rw	RxPDO	All
		Set the acceleration and deceleration in the origin reset position control mode (HM). The deceleration of the home reset position control mode (HM) is also used for this object. When each homing method is finally stopped (when the origin position is checked out), the setting of this object is not needed, and the servo lock stops. If set to 0, internal processing is treated as 1.					

2) Objects associated with HM control mode (monitor)

Index	Sub-index	Name	Unit	Range	Data type	Access	PDO
6041h	00h	Statusword	-	0~65535	U16	ro	TxPDO
60E3h	-	Supported homing method	-	-	-	-	TxPDO
	00h	Number of entries	-	1~254	U8	ro	TxPDO
	01h	1st supported homing method	-	0~32767	U16	ro	TxPDO

	20h	32nd supported homing method	-	0~32767	U16	ro	TxPDO

Other associated objects with common position control

Index	Sub-index	Name	Unit	Range	Data type	Access	PDO
6062h	00h	Position demand value	Command unit	-2147483648~2147483647	I32	ro	TxPDO
6063h	00h	Position actual internal value	pulse	-2147483648~2147483647	I32	ro	TxPDO
6064h	00h	Position actual value	Command unit	-2147483648~2147483647	I32	ro	TxPDO
6065h	00h	Following error window	Command unit	0~4294967295	U32	rw	RxPDO
6066h	00h	Following error time out	1ms	0~65535	U16	rw	RxPDO
6067h	00h	Position window	Command unit	0~4294967295	U32	rw	RxPDO
6068h	00h	Position window time	1ms	0~65535	U16	rw	RxPDO
606Ch	00h	Velocity actual value	Command unit/s	-2147483648~2147483647	I32	ro	TxPDO
6074h	00h	Torque demand	0.1%	-32768~32767	I16	ro	TxPDO
6076h	00h	Motor rated torque	Mn·m	0~4294967295	U32	ro	TxPDO
6077h	00h	Torque actual value	0.1%	-32768~32767	I16	ro	TxPDO
60F4h	00h	Following error actual value	Command unit	-2147483648~2147483647	I32	ro	TxPDO
60FAh	00h	Control effort	Command unit/s	-2147483648~2147483647	I32	ro	TxPDO
60FCh	00h	Position demand internal value	pulse	-2147483648~2147483647	I32	ro	TxPDO

Note: 6064h (position feedback) will reset after HM homing.

Other related objects with common actions

Index	Sub-index	Name	Unit	Range	Data type	Access	PDO
603Fh	00h	Error Code	-	0~65535	U16	ro	TxPDO
60B9h	00h	Touch probe status	-	0~65535	U16	ro	TxPDO
60BAh	00h	Touch probe pos1 pos value	Command unit	-2147483648~2147483647	I32	ro	TxPDO
60BBh	00h	Touch probe pos1 neg value	Command unit	-2147483648~2147483647	I32	ro	TxPDO
60BCh	00h	Touch probe pos2 pos value	Command unit	-2147483648~2147483647	I32	ro	TxPDO
60BDh	00h	Touch probe pos2 neg value	Command unit	-2147483648~2147483647	I32	ro	TxPDO

Statusword (6041h) < functions in hm control mode >

Index	Sub-index	Name	Range	Data type	Access	PDO	Op-mode								
6041h	00h	Statusword	0~65535	U16	ro	TxPDO	All								
Servo driver status															
Bit information															
15		14		13		12		11		10		9		8	
r		oms				ila		oms		rm		r			
				Homing error		Homing attained		Target reached							
7		6		5		4		3		2		1		0	
W		sod		qs		ve		f		oe		so		rsto	
r = reserved(not corresponding)								w = warning							
sod = switch on disabled								qs = quick stop							
oms = operation mode specific (control mode is based on bit)								ve = voltage enabled							
ila = internal limit active								f = fault							
oe = operation enabled								so = switched on							
rm = remote															
rsto = ready to switch on															

bit13,12,10(operation mode specific):

Bit	Name	Value	Definition
10	target reached	0	In action
		1	Stop status
12	homing attained	0	origin point reset action not completed
		1	origin point reset action completed
13	Homing error	0	origin point reset abnormality does not occur
		1	Abnormal origin reset (the origin reset action cannot be executed normally)

bit13,12,10(operation mode specific):

Bit13	Bit12	Bit10	Definition
0	0	0	Origin point reset in action
0	0	1	Origin point reset action interrupted or not started
0	1	0	Origin point reset action is completed, but the target position is not reached
0	1	1	Normal completion of origin point reset
1	0	0	Detect out that the original point reset abnormality is still in operation
1	0	1	Detect out the abnormal origin reset and stop state

bit12 (homing attained) is 0 in the following states:

- When the power is on
- When the ESM state is transferred from Init to PreOP
- At the beginning of origin point reset

When the homing action (method35, method37) without motor action is started, the homing attached is also set to 0. However, the time set to 0 is short (about 2 ms).

Supported homing method (60E3)

Index	Sub-index	Name	Unit	Range	Data type	Access	PDO
60E3h	-	Supported Homing method	-	-	-	-	TxPDO
		Indicates the supported homing method					
	00h	Number of entries	-	1~254	U8	ro	TxPDO
		Represents the number of homing methods supported by 60E3h (supported homing method).					
	01h	1st supported Homing method	-	0~32767	U16	ro	TxPDO
		Indicates that the first home method is supported.					

	20h	32nd supported Homing method	-	0~32767	U16	ro	TxPDO
		Indicates that the 32nd home method is supported					

Index	Sub-index	bit 15~8	bit 7~0
		Reserved	Supported Homing method
60E3	01h	0	1
	02h	0	2
	03h	0	3
	04h	0	4
	05h	0	5
	06h	0	6
	07h	0	7
	08h	0	8
	09h	0	9
	0Ah	0	10
	0Bh	0	11
	0Ch	0	12
	0Dh	0	13
	0Eh	0	14
	0Fh	0	17
	10h	0	18
	11h	0	19
	12h	0	20
	13h	0	21
	14h	0	22
15h	0	23	
16h	0	24	
17h	0	25	
18h	0	26	
19h	0	27	
1Ah	0	28	
1Bh	0	29	
1Ch	0	30	
1Dh	0	33	
1Eh	0	34	
1Fh	0	35	
20h	0	37	

The relationship between * value and Homing method please refer to 6098h (Homing method).

The action of HM control mode (Homing action)

When using in incremental mode, in order to initialize the location information before starting the normal action, please execute the homing action.

- ◆ After the origin position is detected, this position is used as the reference to initialize the following objects (preset).
6062h(Position demand value)= 6064h(Position actual value)= 607Ch(Home offset)
6063h(Position actual internal value)= 60FCh(Position demand internal value)= 0
- ◆ If the origin point reset is performed, the position information is initialized (preset). Therefore, it is necessary to obtain the data based on the old location information again (touch probe location, etc.).

- ◆ Whether 607Ch (home offset) is changed or not in the homing action, it is not reflected in the executing homing action. The next homing action will be reflected (initialization of position information upon completion).
- ◆ 607C (me offset) is only valid in homing mode 35 and 37.
- ◆ If the edge of the switch signal (T, NOT, HOME) is used as the detection position of the origin, please assign each clamping compensation pin to SI1, SI2, SI3. If it is not allocated correctly, an error will be reported in the origin reset. (Note: P5-22 of DS5C1 series servo is the setting address of positive limit, the default value is 1, the corresponding servo terminal is SI1; P5-23 is the setting address of negative limit NOT, the default value is 2, the corresponding servo terminal is SI2; P5-27 is the setting address of origin, the default value is 3, the corresponding servo terminal is SI3.)
- ◆ In the Method diagrams described later, the meaning of below terms:

Index pulse	Z phase signal of encoder
Home switch	Theoretical signal state of near origin input(ME)
Positive limit	Theoretical signal state of forward drive inhibit input(POT)
Negative limit	Theoretical signal state of negative drive inhibit input(NOT)

- ◆ After the update (sending) of action command and the operation enabled command, please input after about 100 ms.
- ◆ The following shows the timing of the HM control mode.

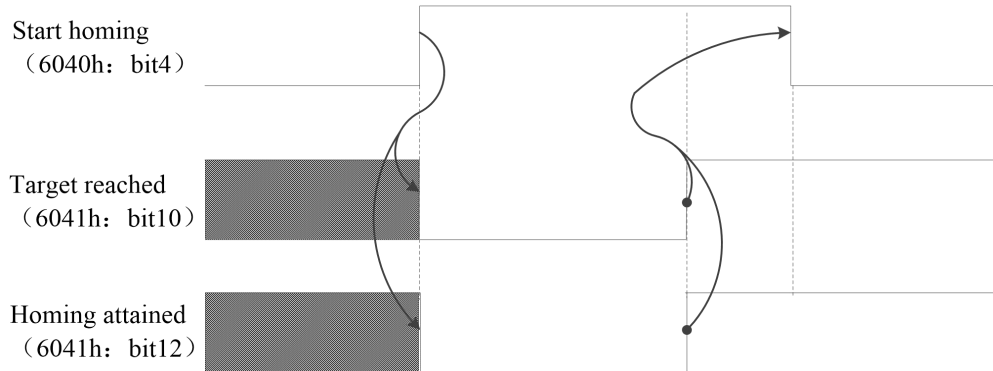

- ◆ Homing error occurrence condition

According to the homing action, the conditions for an exception (homing error = 1) are as follows.

Homing error occurrence condition	Details
Startup except Operation enabled	Start Homing when PDS status is not Operation enabled (except for method35, 37)
Startup under target speed 0	Startup Homing when 6099h-01h and 6099h-02h is set to 0 (except 6099h-02h of method33, 34 and 6099h-01h, 6099h-02h of method35, 37 are 0)
detected out two Limit switch	Two limit switches of positive/negative are detected during the homing start or the homing action.
Use Limit switch	Under the method reversed by limit switch, in the reverse deceleration action after the rising edge of limit switch is detected, the falling edge of limit switch is detected
Home switch, Limit switch not distributed	Not distribute IO terminal

7.5.2 Related parameters

Register	Explanation
RXPDO[0x6040]	Control word, modify the control word and turn it back to the original point
RXPDO[0x6098]	Homing method
RXPDO[0x609A]	Homing acceleration
RXPDO[0x6060]	Set to 6 when the motor is not enabled
SDO[0x6099]	The speed of returning to the original point can be modified online through COE-Online

Control word (6040h)

Set it to (0x06 > 0x0f > 0x1f) in sequence, enable the driver and start the motor to operate, and start it back to the original point.

7.5.3 Homing method

Now DS5C1 servo driver support 1~14, 17~30, 33, 34, 35, 37 and -1, -2 homing method (-1, -2 mode is only supported by DS5C1 firmware version 3791 and higher).

If the slave station of other brands is used, the method of homing to the original point shall be subject to the slave station Manual of the corresponding brands.

■ Method -1: (firmware version 3791 and higher supported)

The servo motor first runs at a forward low speed with the set value of 6099h:02 (low speed for homing). After hitting the mechanical limit position, if the absolute value of the torque reaches the upper limit of P9-17 (touch stop homing torque threshold), and the absolute value of the speed is lower than the set value of P9-16 (touch stop homing speed threshold), this state is maintained for the set time of P9-18 (touch stop homing time threshold), and it is judged to have reached the mechanical limit position. Then it can be divided into two situations:

- ① P7-20=0, and the number of quantitative pulses is 0. At this point, immediately stop the machine and calibrate it as zero (position reset);

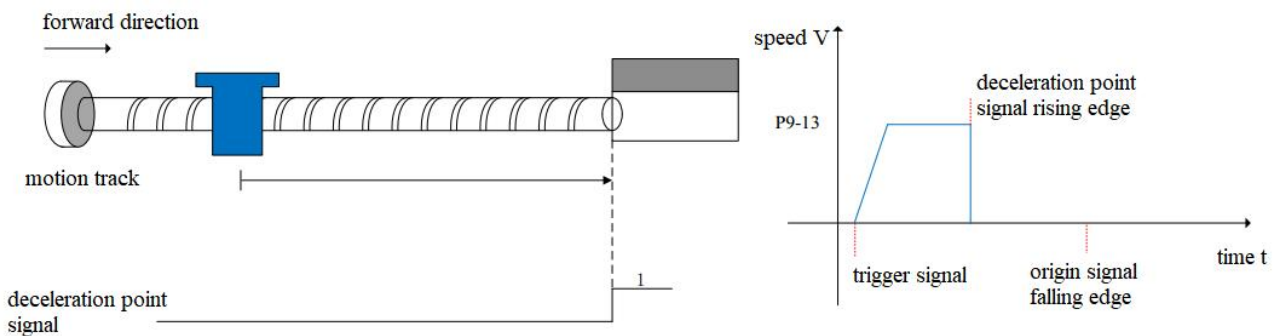

- ② P7-20>0, the number of quantitative pulses is 0, and it runs in reverse at the setting homing low speed. When encountering the rising edge of P7-20 Z-phase signals, it immediately stops and calibrates the zero point (position reset).

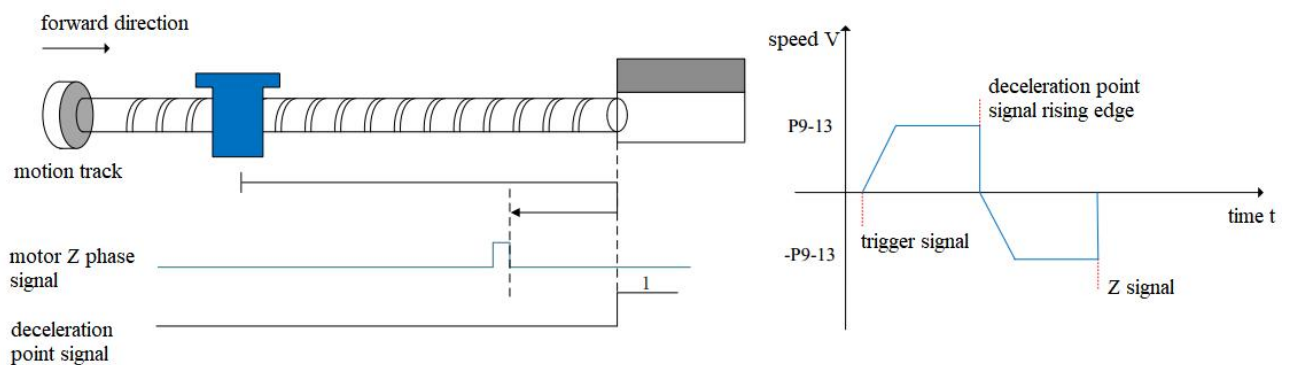

- ③ P7-20=0, and the number of quantitative pulses is not 0. First, run in the forward direction at low speed (6099h: 02), and after touching the mechanical point, run in the reverse direction at homing high speed (6099h: 01). After the quantitative pulse length is reached, stop the machine and calibrate it as the zero point (Ecat position is reset to zero);

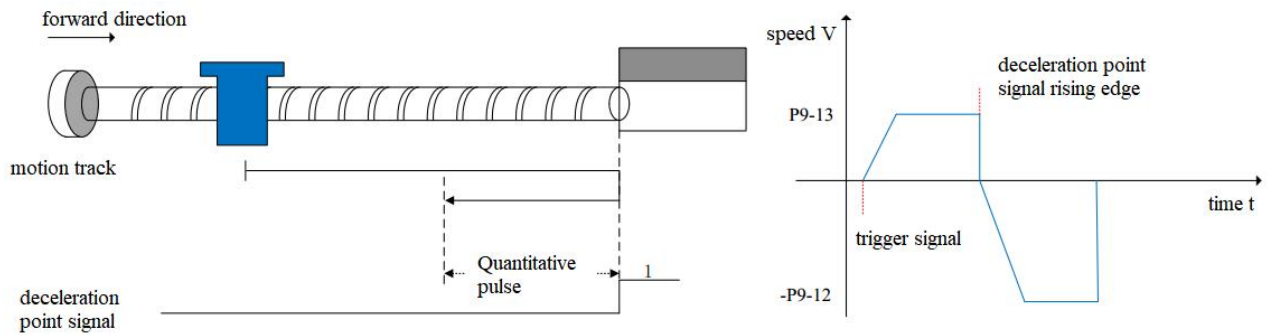

- ④ P7-20>0, the number of quantitative pulses is not 0. First, run in the forward direction at low speed (6099h: 02), and then run in the reverse direction at the set homing low speed (6099h: 02) when encountering the mechanical origin, stop machine when encountering the rising edge of P7-20 Z-phase signals. After stopping, run the quantitative pulse length at the homing high speed (6099h: 01), and then stop the machine. Calibrate the zero point (Ecat position is reset).

Parameter	Function	Unit	Default value	Range	Effective time	Suitable mode
P7-20	Ethercat homing find the Z phase numbers (firmware version 3791 and higher supported)	-	1	-9999~9999	○	EtherCAT mode



The positive and negative values of the P7-20 parameters represent the direction of homing, with positive values indicating the forward direction of finding the origin, negative values indicating the reverse direction of finding the origin, and absolute values indicating the number of Z-phase points for homing.

■ Method -2: (firmware version 3791 and higher supported)

Similar to the previous homing action, running in the opposite direction.

■ Method 1:

This method, if negative limit switch is inactive, the initial operation direction turns into be negative direction.(An inactive state is shown in the state of low level by a figure)

Home detection position is the first Index pulse detection position in the positive side position of after a negative limit signal becomes inactive.

(Please refer to the figure below)

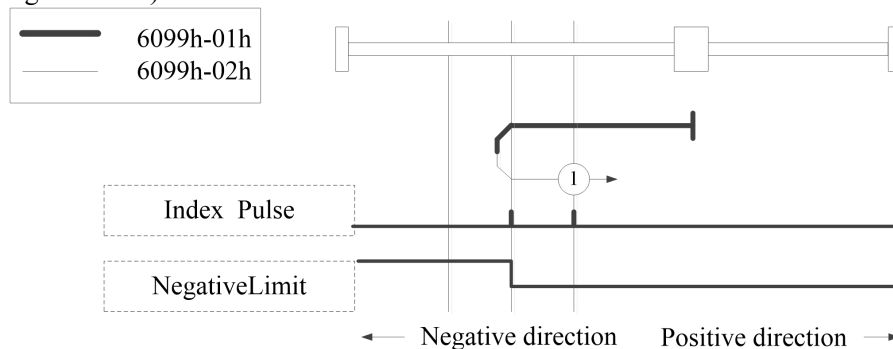

Homing on negative limit switch and index pulse

■ Method 2:

This method, if positive limit switch is inactive, the initial operation direction turns into be positive direction.(An inactive state is shown in the state of low level by a figure)

Home detection position is the first Index pulse detection position in the negative side position of after a positive limit signal becomes inactive.
 (Please refer to the figure below)

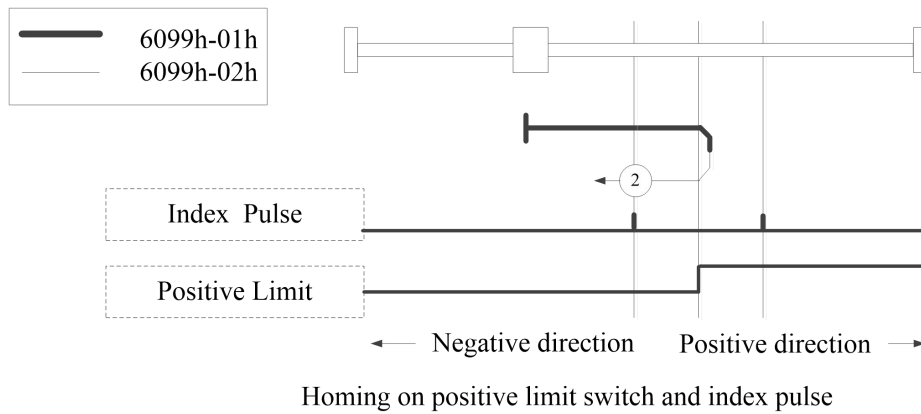

■ Method 3, 4:

The initial direction of operation depends on the state of the home switch.
 The origin position is at the negative side of the home switch or the initial index pulse detection position on the positive direction side.
 (Please refer to the figure below)

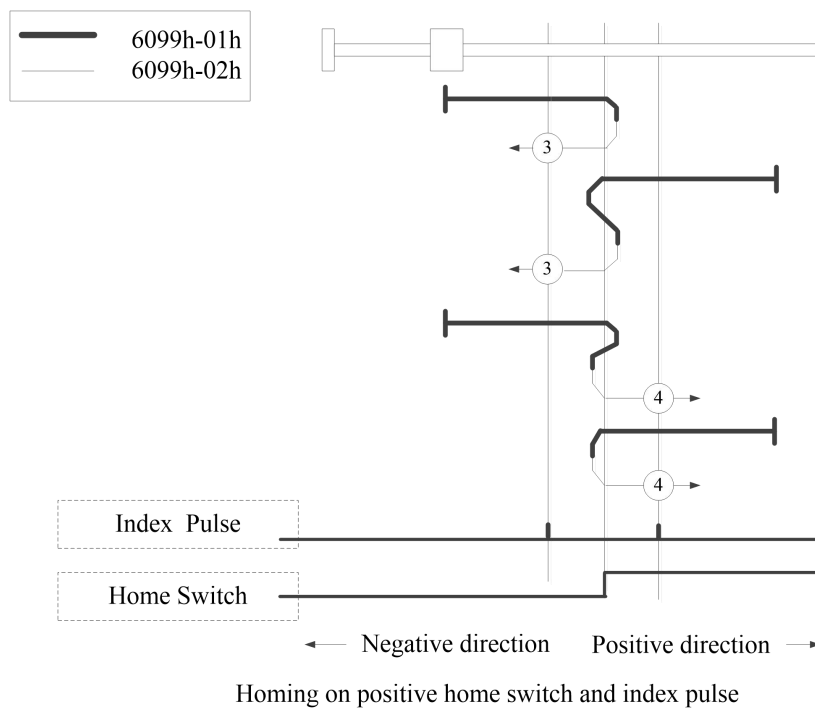

■ Method 5, 6:

The initial direction of operation depends on the state of the home switch.
 The origin position is at the negative side of the home switch or the initial index pulse detection position on the positive direction side.
 (Please refer to the figure below)

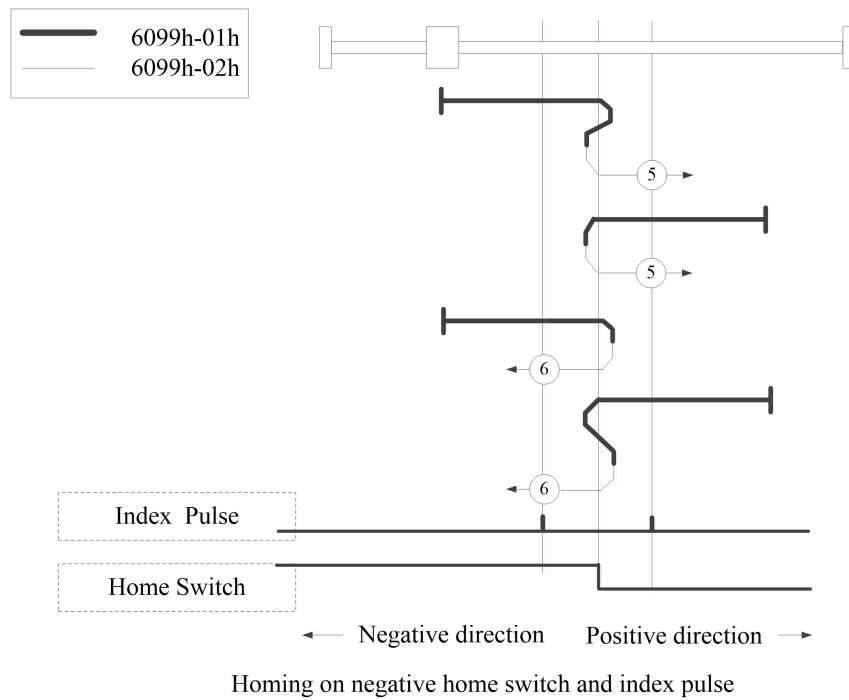

■ Method 7~14:

These methods, use Home switch and Index pulse.

Method 7 and 8 initial operation directions, when home switch is active at the time of a start of operation, becomes the negative direction.

Method 9 and 10 initial operation directions, when home switch is active at the time of a start of operation, becomes the positive direction.

Method 11 and 12 initial operation directions, when home switch is active at the time of a start of operation, becomes the positive direction.

Method 13 and 14 initial operation directions, when home switch is active at the time of a start of operation, becomes the negative direction.

Home detection position is the near Index pulse in the rising or falling edge of home switch.
 (Please refer to the figure below)

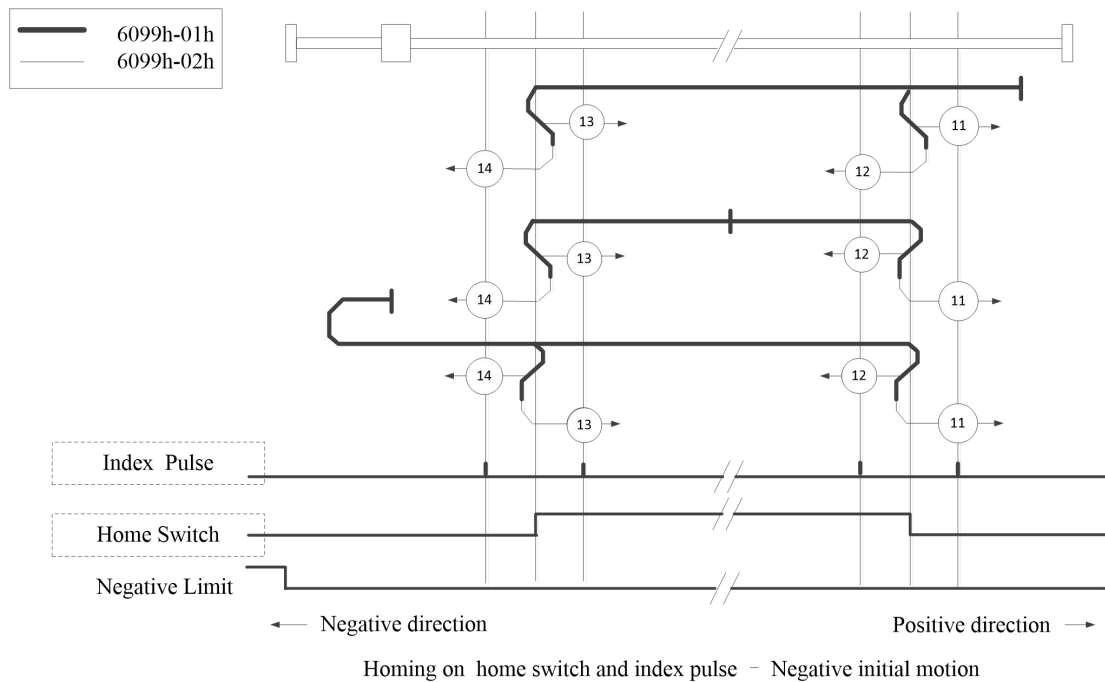
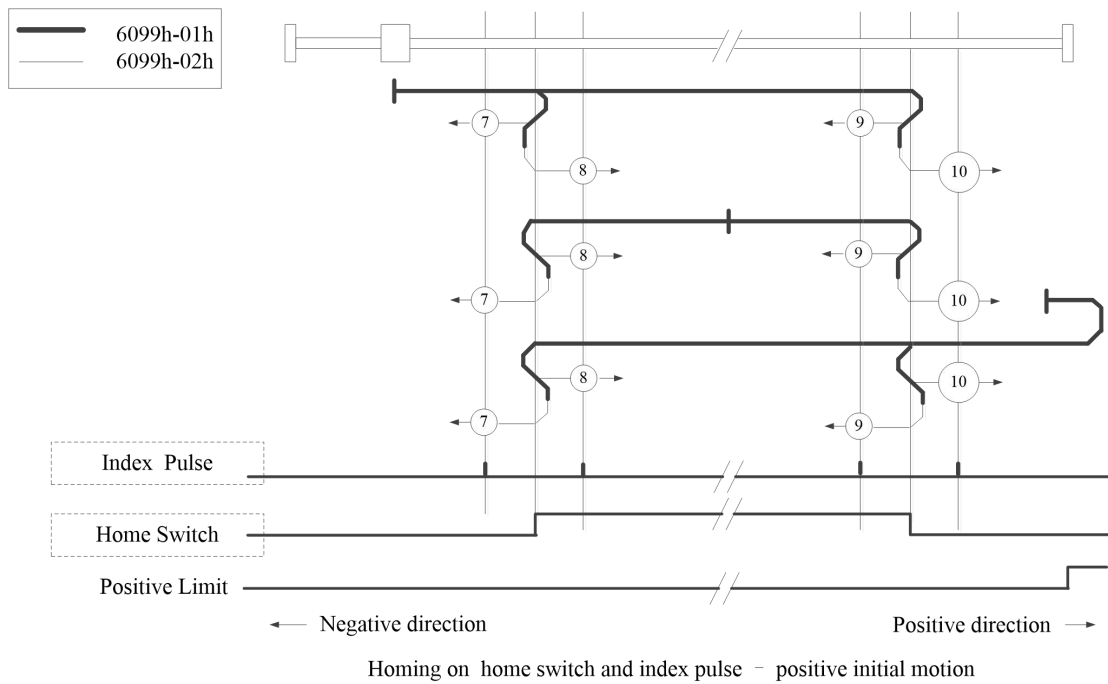

■ Method 17:

This method resembles Method 1.

The difference is home detection position is not Index pulse. It is becoming the position where limit switch changed.

When NOT is not allocated, Homing error = 1.

(Please refer to the figure below)

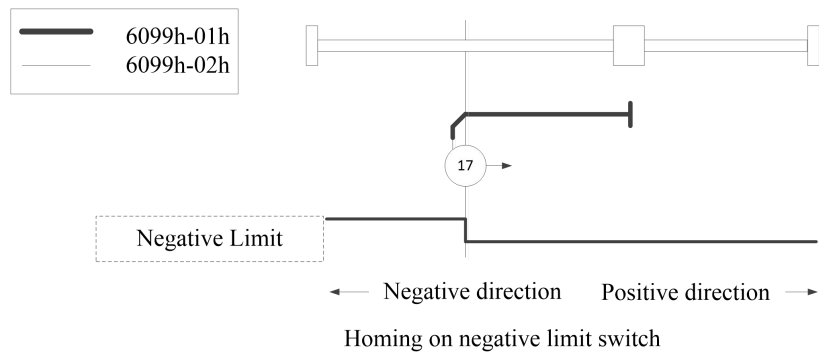

■ Method 18:

This method resembles Method 2.

The difference is home detection position is not Index pulse. It is becoming the position where limit switch changed.

When POT is not allocated, Homing error = 1.

(Please refer to the figure below)

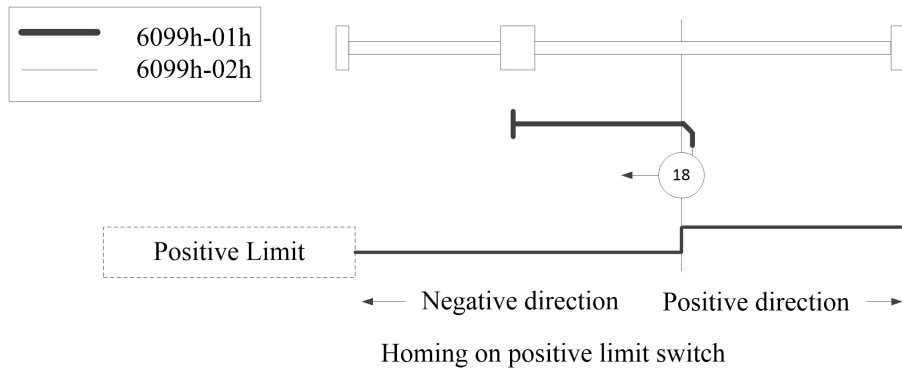

■ Method 19,20:

These methods resemble Method 3 and 4.

The difference is home detection position is not Index pulse. It is becoming the position where Home switch changed.

When HOME is not assigned, homing error = 1.

(Please refer to the figure below)

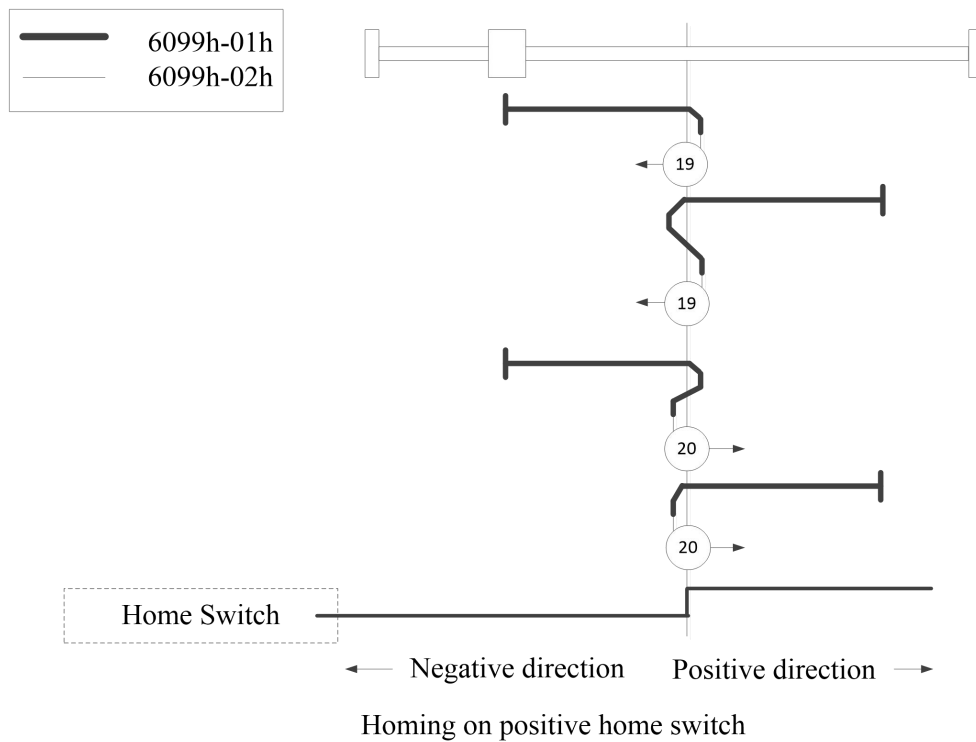

■ Method 21,22:

These methods resembles Method 5 and 6.

The difference is home detection position is not Index pulse. It is becoming the position where Home switch changed.

When HOME is not assigned, homing error = 1.

(Please refer to the figure below)

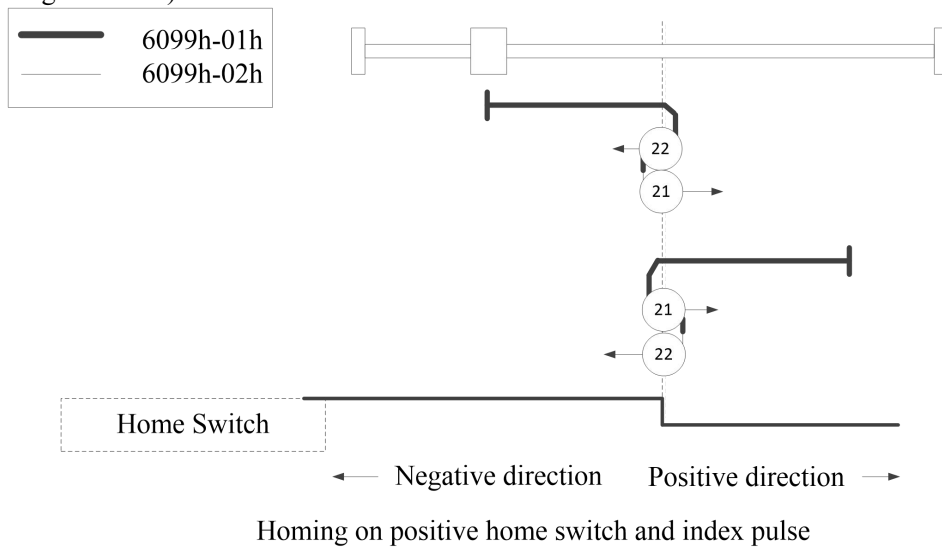

■ Method 23,24,25,26:

These methods resembles Method 7, 8, 9, 10.

The difference is home detection position is not Index pulse. It is becoming the position where Home switch changed.

When HOME,POT is not assigned, homing error = 1.

(Please refer to the figure below)

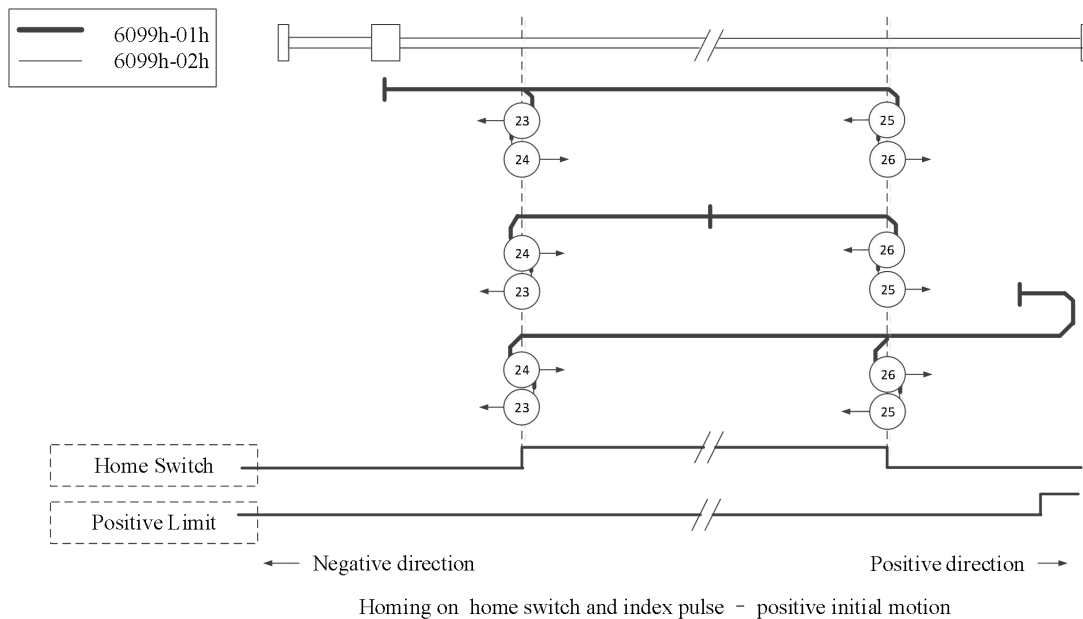

■ Method 27,28,29,30:

These methods resembles Method 11,12,13,14.

The difference is home detection position is not Index pulse. It is becoming the position where Home switch changed.

When HOME,NOT is not assigned, homing error = 1.(Please refer to the figure below)

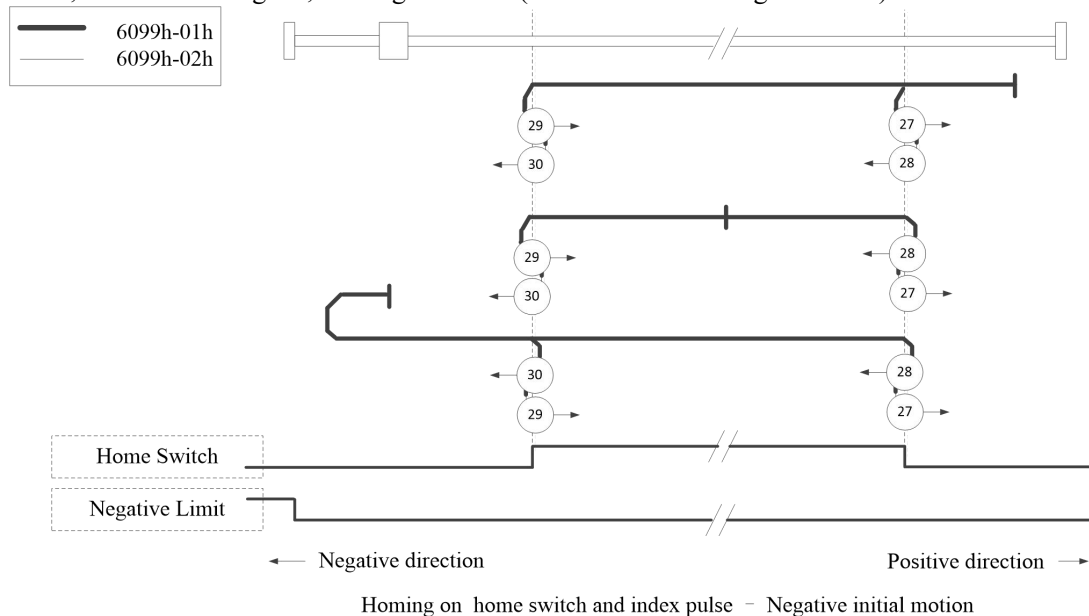

■ Method 33, 34:

This method only uses Index pulse.

After the direction action shown in the figure, the index pulse is detected as the home detection position. (Please refer to the figure below)

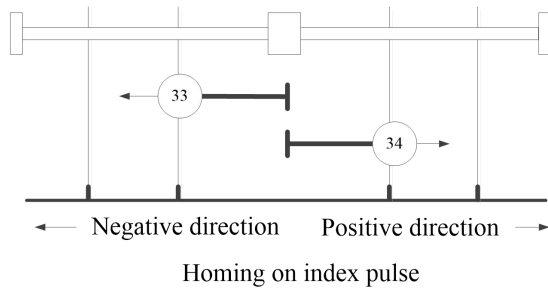

■ Method 35, 37:

In modes 35 and 37, the position after power on is the home position.

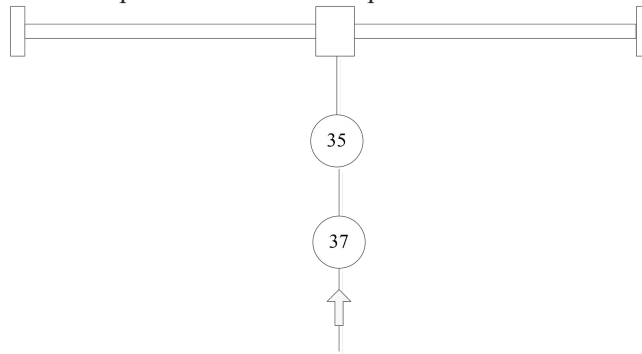

7.6 PP mode

PP (profile position control mode) is the position control mode that specifies the target position, target speed, acceleration/deceleration, etc., and acts after generating a position command in the servo driver. For this control mode, please check the communication cycle 500 μs or more.

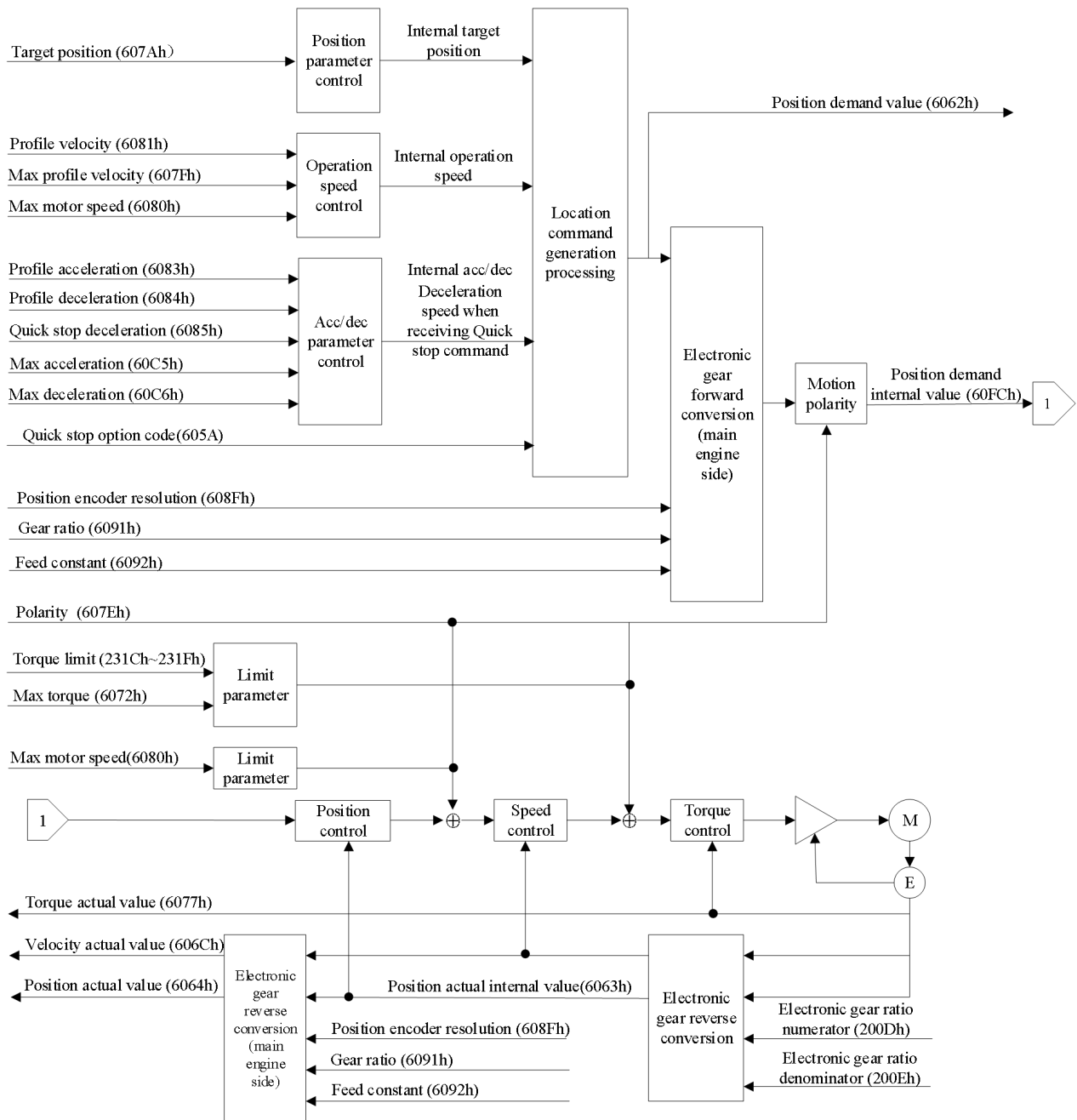

7.6.1 Related parameters

1) PP control mode related objects(Command · settings)

Index	Sub-index	Name	Units	Range	Data type	Access	PDO
6040h	00h	Control word	-	0~65535	U16	rw	RxPDO
6072h	00h	Max torque	0.1%	0~65535	U16	rw	RxPDO
607Ah	00h	Target position	Command unit	-2147483648~2147483647	I32	rw	RxPDO
607Dh	-	Software position limit	-	-	-	-	-
	00h	Number of entries	-	2	U8	ro	NO

Index	Sub-index	Name	Units	Range	Data type	Access	PDO
	01h	Min position limit	Command unit	-2147483648~2147483647	I32	rw	RxPDO
	02h	Max position limit	Command unit	-2147483648~2147483647	I32	rw	RxPDO
607Fh	00h	Max profile velocity	Command unit/s	0~4294967295	U32	rw	RxPDO
6080h	00h	Max motor speed	r/min	0~4294967295	U32	rw	RxPDO
6081h	00h	Profile velocity	Command unit/s	0~4294967295	U32	rw	RxPDO
6082h	00h	End velocity	Command unit/s	0~4294967295	U32	rw	RxPDO
6083h	00h	Profile acceleration	Command unit/s ²	0~4294967295	U32	rw	RxPDO
6084h	00h	Profile deceleration	Command unit/s ²	0~4294967295	U32	rw	RxPDO
60B1h	00h	Velocity offset	Command unit/s	-2147483648~2147483647	I32	rw	RxPDO
60B2h	00h	Torque offset	0.1%	-32768~32767	I16	rw	RxPDO
60C5h	00h	Max acceleration	Command unit/ s ²	0~4294967295	U32	rw	RxPDO
60C6h	00h	Max deceleration	Command unit/ s ²	0~4294967295	U3	rw	RxPDO

Other related objects with common actions

Index	Sub-index	Name	Units	Range	Data type	Access	PDO
605Ah	00h	Quick stop option code	-	0~7	I16	rw	NO
605Bh	00h	Shutdown option code	-	0~1	I16	rw	NO
605Ch	00h	Disable operation option code	-	0~1	I16	rw	NO
605Dh	00h	Halt option code	-	1~3	I16	rw	NO
605Eh	00h	Fault reaction option code	-	0~2	I16	rw	NO
607Dh	-	Software position limit	-	-	-	-	-
	00h	Number of entries	-	2	U8	ro	NO
	01h	Min position limit	Command unit	-2147483648~2147483647	I32	rw	RxPDO
	02h	Max position limit	Command unit	-2147483648~2147483647	I32	rw	RxPDO
607Ch	00h	Home offset	Command unit	-2147483648~2147483647	I32	rw	RxPDO
607Eh	00h	Polarity	-	0~255	U8	rw	NO
6085h	00h	Quick stop deceleration	Command unit/s ²	0~4294967295	U32	rw	RxPDO
6086h	00h	Motion profile type	-	-32768~32767	I16	rw	RxPDO
608Fh	-	Position encoder resolution	-	-	-	-	-
	00h	Number of entries	-	2	U8	ro	NO
	01h	Encoder increments	pulse	1~4294967295	U32	ro	NO
	02h	Motor revolutions	r(motor)	1~4294967295	U32	ro	NO
6091h	-	Gear ratio	-	-	-	-	-
	00h	Number of entries	-	2	U8	ro	NO
	01h	Motor revolutions	r(motor)	1~4294967295	U32	ro	NO
	02h	Shaft revolutions	r(shaft)	1~4294967295	U32	ro	NO
6092h	-	Feed constant	-	-	-	-	-
	00h	Number of entries	-	2	U8	ro	NO
	01h	Feed	Command unit	1~4294967295	U32	ro	NO

Index	Sub-index	Name	Units	Range	Data type	Access	PDO
	02h	Shaft revolutions	r(shaft)	1~4294967295	U32	ro	NO
60B8h	00h	Touch probe function	-	0~65535	U16	rw	RxPDO

Controlword(6040h) <functions in PP control mode>

Index	Sub-index	Name	Range	Data type	Access	PDO	Op-mode		
		Controlword	0~65535	U16	rw	RxPDO	All		
		Set the control command to the servo driver such as PDS state conversion.							
		Bit information							
		15	14	13	12	11	10	9	8
		r						om	h
		7	6	5	4	3	2	1	0
		fr	oms			eo	qs	ev	so
			abs/rel	Change set immediately	New set-point				
		r = reserved(not corresponding)			fr = fault reset				
		oms = operation mode specific			eo = enable operation				
					qs = quick stop				
		h = halt			ev = enable voltage				
		so = switch on							

Bit6-4(operation mode specific):

Bit	Name	Value	Definition
4	new set-point	0 -> 1	Start the positioning action and trigger the setting value update. Get the new location determination task (607Ah (Target position), 6081h (Profile velocity), etc.).
5	change set immediately	0	Complete the currently running positioning action. That is, during the movement, if the target position 607A, acceleration 6083, deceleration 6084 are changed, and then the control command is sent, it will not operate according to the new movement parameters. It is necessary to send a new command after the last movement is completed to execute the new movement.
		1	Interrupt the current positioning action and immediately start the downward positioning action. That is, during the movement, the target position 607A, acceleration 6083 and deceleration 6084 are changed, and then the control command is sent. For example, after the control word 0x6f (111) → 0x7F (127) (relative mode) or 0x2F (47) → 0x3f (63) (absolute mode) is changed, the system will immediately operate according to the new motion parameters.
6	absolute/relative	0	607Ah(target position) Process as absolute position
		1	607Ah(target position) Process as absolute position

Note:

(1) please do not change the acceleration and deceleration during motor operation (*).

If the acceleration and deceleration are changed, please change bit4 (new set point) from 0 to 1 after the motor stops.

6083h (Profile acceleration)

6084h (Profile deceleration)

60C5h (Max acceleration)

60C6h (Max deceleration)

(2) In the following status, if set point is executed (bit4 (new set-point) is changed from 0 to 1), please note that its positioning task is revoked.

--6081h (profile speed) = 0.

(3) if the driving prohibition in deceleration is detected according to halt = 1, all the positioning tasks are invalid.

(4) start the PP action, and keep it for more than 2ms until the next PP action is started (new set-point changes from 0 to 1).

2) Related objects in pp control mode(monitor)

Index	Sub-index	Name	Unit	Range	Data type	Access	PDO
6041h	00h	Controlword	-	0~65535	U16	ro	TxPDO

Other related objects with common position control.

Index	Sub-index	Name	Unit	Range	Data type	Access	PDO
6062h	00h	Position demand value	Command unit	-2147483648~2147483647	I32	ro	TxPDO
6063h	00h	Position actual internal value	pulse	-2147483648~2147483647	I32	ro	TxPDO
6064h	00h	Position actual value	Command unit	-2147483648~2147483647	I32	ro	TxPDO
6065h	00h	Following error window	Command unit	0~4294967295	U32	rw	RxPDO
6066h	00h	Following error time out	1ms	0~65535	U16	rw	RxPDO
6067h	00h	Position window	Command unit	0~4294967295	U32	rw	RxPDO
6068h	00h	Position window time	1ms	0~65535	U16	rw	RxPDO
606Ch	00h	Velocity actual time	Command unit/s	-2147483648~2147483647	I32	ro	TxPDO
6074h	00h	Torque demand	0.1%	-32768~32767	I16	ro	TxPDO
6076h	00h	Motor rated torque	Mn·m	0~4294967295	U32	ro	TxPDO
6077h	00h	Torque actual value	0.1%	-32768~32767	I16	ro	TxPDO
60F4h	00h	Following error actual value	Command unit	-2147483648~2147483647	I32	ro	TxPDO
60FAh	00h	Control error	Command unit/s	-2147483648~2147483647	I32	ro	TxPDO
60FCh	00h	Position demand internal value	pulse	-2147483648 ~ 2147483647	I32	ro	TxPDO

Other related objects with common actions.

Index	Sub-index	Name	Unit	Range	Data type	Access	PDO
603Fh	00h	Error code	-	0~65535	U16	ro	TxPDO
60B9h	00h	Touch probe status	-	0~65535	U16	ro	TxPDO
60BAh	00h	Touch probe pos1 pos value	Command unit	-2147483648~2147483647	I32	ro	TxPDO
60BBh	00h	Touch probe pos1 neg value	Command unit	-2147483648~2147483647	I32	ro	TxPDO
60BCh	00h	Touch probe pos2 pos value	Command unit	-2147483648~2147483647	I32	ro	TxPDO
60BDh	00h	Touch probe pos2 neg value	Command unit	-2147483648~2147483647	I32	ro	TxPDO

Statusword (6041h) < functions in pp control mode >

Index	Sub-index	Name	Range	Data type	Access	PDO	Op-mode				
6041h	00h	Statusword	0~65535	U16	ro	TxPDO	All				
		Servo driver status									
		Bit information									
		15	14	13	12	11	10	9	8		
		r		oms			ila	oms		rm	r
				Following Error	set- point acknowledge		Target Reached				
		7	6	5	4	3	2	1	0		
		w	sod	Qs	ve	f	oe	so	rsto		
		r = reserved(not corresponding)				w = warning					
		oms = operation mode specific (control mode is based on bit)				sod = switch on disabled					
ila = internal limit active				qs = quick stop							
oe = operation enabled				ve = voltage enabled							
rm = remote				f = fault							
rsto = ready to switch on				so = switched on							

bit13,12,10(operation mode specific):

Bit	Name	Value	Definition
10	target reached	0	halt=0(normal): positioning incompleted halt=1(stop as halt):shaft is decelerating
		1	halt=0(normal):positioning completed halt=1(stop as halt):shaft stop(shaft speed is 0)
12	set-point acknowledge	0	The new-setpoint is 0, and the buffer is empty after the current target position is executed (in execution)
		1	The new location task puts data into the buffer, which is not empty.
13	following error	0	60F4h(Following error actual value) (= 6062h(Position demand value)- 6064h(Position actual value)), not over the setting range of 6065h(Following error window), or the value of 60F4h is over 6065h, not through the setting time of 6066h.
		1	The value of 60F4h (Following error actual value), the status over the setting range of 6065h (Following error window), above the setting time of 6066h(Following error time out), continue.

bit10:target reached(Position reached)

When the servo enable state (operation effective state) and the set-points all give the completion instruction generation state, the difference between 6062h (position required value) and 6064h (position actual value) is within the range set in 6067h (position window). After the time set in 6068H (position window time), the bit10 (target reached) of 6041h (status word) changes to 1.

Bit	Name	Vlaue	Definition
10	Target reached	0	halt=0 (normal): positioning incompleted halt=1 (stop as halt): shaft is decelerating
		1	halt=0 (normal): positioning completed halt=1 (stop as halt): shaft stop (shaft speed is 0)

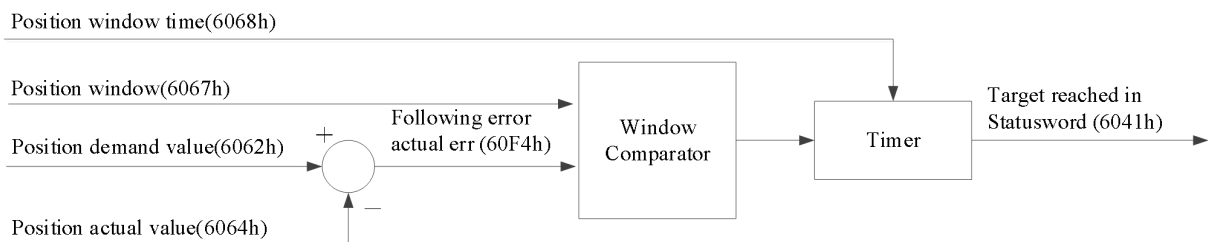

Location arrival diagram

Index	Sub-index	Name	Units	Range	Data type	Access	PDO	OP-mode
6067h	00h	Position window	Command unit	0~4294967295	U32	rw	RxPDO	PP
		The difference between 6062h (Position demand value) and 6064h (Position actual value) is within the set value of this parameter. After the time set in 6068H (Position window time), set the bit10 (Target reached) of 6041h (Status word) as the threshold value of 1. If the difference is a value other than this parameter setting, bit10 of 6041h is 0.						
6068h	00h	Position window time	1ms	0~65535	U16	rw	RxPDO	PP
		The difference between 6062h (position demand value) and 6064h (position actual value) is the time when the bit10 (target reached) of 6041h (status word) is set to 1 in the range of 6067h (position window) setting.						

bit13:following error

The status that the value of 60F4h (Following error actual value) is over the setting range of 6065h (Following error window). If continue the setting time of 6066h (Following error time out), bit13(following error) of 6041h (state word) changes to 1.

Bit	Name	Value	Definition
13	Following error	0	60F4h (Following error actual value) (= 6062h (Position demand value) – 6064h(Position actual value)), not over the setting range of 6065h (Following error window), or the value of 60F4h is over 6065h, not after the setting time of 6066h
		1	The value of 60F4h (Following error actual value) is over the setting range of 6065h (Following error window), above the setting time of 6066h (Following error time out), continue.

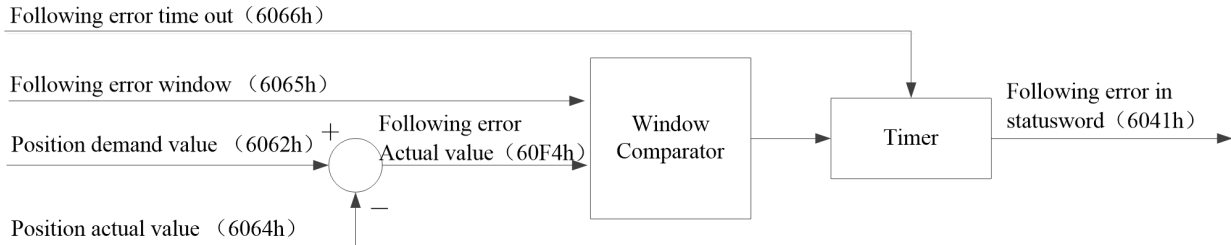

Follow error function diagram

Index	Sub-index	Name	Units	Range	Data type	Access	PDO	OP-mode
6065h	00h	Following error window	Command unit	0~ 4294967295	U32	rw	RxPDO	PP CSP
		60F4h(Following error actual value): the condition except the setting value of this parameter, set 6041h (statusword) bit 13 (following error) to 1.						
6066h	00h	Following error time out	1ms	0~65535	U16	rw	RxPDO	PP CSP
		The status that 60F4h (Following error actual value) value is over the setting range of 6065h (Following error window) is above this parameter, if continue, set 6041h (Statusword) bit13(following error) to 1.						

3)pp control mode action

Action example 1:(basic set-point)

- (1) For the master station, after setting the value of 607AH (Target position), change the bit4 (new set point) of 6040h (control word) from 0 to 1. At this time, please also set 6081h (profile velocity).
When 6081h (profile velocity) is 0, the motor does not act.
- (2) from the station, confirm the rising edge (0 → 1) of bit4 (New set-point) of 6040h (control word), 607AH (target position) as the target position to start positioning. At this time, bit12 (set point acknowledge) of 6041h (status word) is changed from 0 to 1.
- (3) For the master station, confirm that bit12 (set-point acknowledge) of 6041h (status word) has changed from 0 to 1, bit4 (new set-point) of 6040h (control word) returns 0.
- (4) For the slave station, confirm that the bit4 (new set-point) of 6040h (control word) has been 0, 6041h (status word) and the bit12 (set-point acknowledge) has changed to 0.
- (5) when the target position is reached, the bit10 (target reached) of 6041h (control word) is changed from 0 to 1.

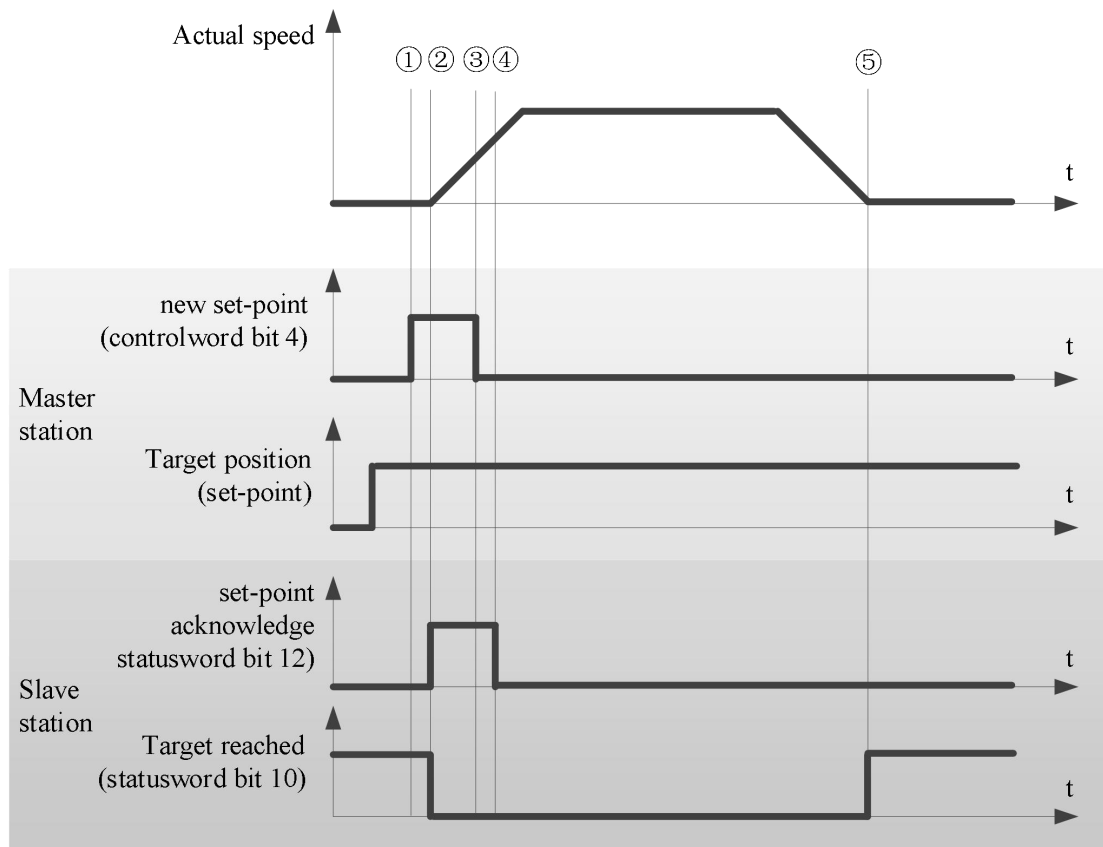

< Set-point example >

Note:

- (1) 6081h (profile velocity) is limited by the smaller one of 607fh (max profile velocity) and 6080h (max motor speed).
- (2) changing the set value of 607FH (max profile velocity) or 6080h (max motor speed) in the action is not reflected in the action.

Action example 2: (Action data change without buffer: single set-point)

When bit5 (change set immediately) of 6040h (control word) is 1, if the data used for positioning action in the action has been changed, the current positioning action will be interrupted and the next positioning action will be started immediately.

- (1) For the master station, confirm that the bit12 (set-point acknowledge) of 6041h (status word) is 0. After changing the value of 607AH (target position), change the bit4 (New set-point) of 6040h (control word) from 0 to 1.
Note: at this time, please do not change the acceleration and deceleration.
- (2) For the slave station, confirm the rising edge (0 → 1) of bit4 (New set-point) of 6040h (control word), and update 607AH (target position) as the new target position immediately. At this time, bit12 (set-point acknowledge) of 6041h (status word) is changed from 0 to 1.
- (3) For master station, confirm that bit12 (set point acknowledge) of 6041h (status word) has changed from 0 to 1, bit4 (new set-point) of 6040h (control word) returns 0.
- (4) For slave station, confirm that the bit4 (new set point) of 6040h (control word) has been 0, the bit12 (set point acknowledge) of 6041h (status word) is 0.

Note: 6081h (profile velocity) can be changed in the same steps (1) - (4).

After changing the 607Ah (target position) and 6081h (profile velocity), update the 607Ah (target position) and 6081h (profile velocity) simultaneously according to the above steps (1) - (4).

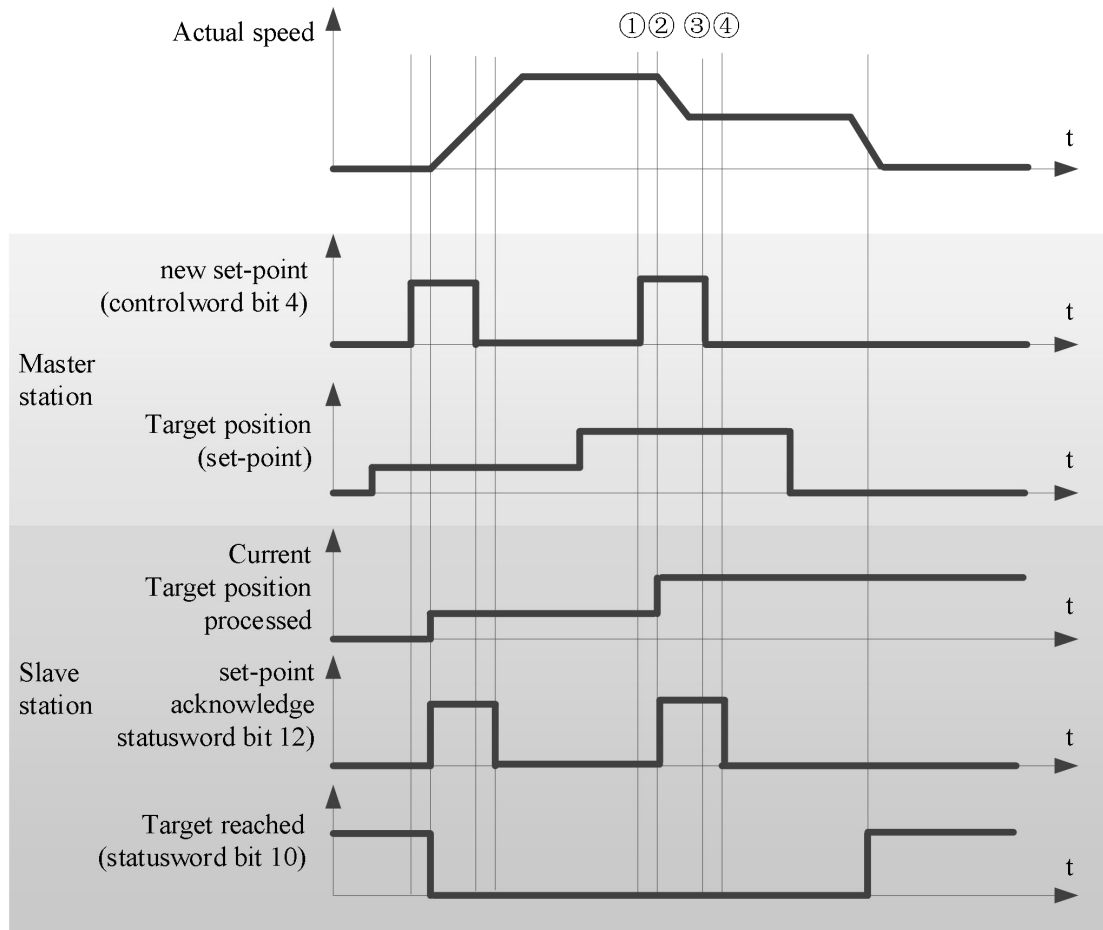

< handshaking procedure for the single set-point method >

7.6.2 Common parameters

PP Control mode associated object(Command setting)

Register	Explanation	Unit
RXPDO[0x6040]	Controlword	-
RXPDO[0x6060]	Set to 1	-
RXPDO[0x607A]	Target position	Command unit
RXPDO[0x6072]	Max torque	0.1%
RXPDO[0x607F]	Max profile velocity	Command unit /s
RXPDO[0x6080]	Max motor speed	r/min
RXPDO[0x6081]	Profile velocity	Command unit /s
RXPDO[0x6083]	Profile acceleration	Command unit /s ²
RXPDO[0x6084]	Profile deceleration	Command unit /s ²
RXPDO[0x60C5]	Max acceleration	Command unit /s ²
RXPDO[0x60C6]	Max deceleration	Command unit /s ²
RXPDO[0x6065]	Following error window	Command unit
RXPDO[0x6066]	Following error time out	ms
RXPDO[0x6067]	Position window	Command unit
RXPDO[0x6068]	Position window time	ms

Note:

- (1) 6081h (Profile velocity) is limited by the smaller of 607Fh (Max profile velocity) and 6080h (Max motor speed).
- (2) The set values of 607Fh (Max profile velocity) or 6080h (Max motor speed) are changed during the operation and are not reflected in the operation.

PP control mode associated object(Command monitoring)

Register	Explanation	Unit
TXPDO[0x6041]	Statusword	-
TXPDO[0x6063]	Position actual internal value	Command unit
TXPDO[0x6064]	Position actual value	Command unit
TXPDO[0x606C]	Velocity actual value	Command unit /s
TXPDO[0x6077]	Torque actual value	0.1%
TXPDO[0x60F4]	Following error actual value	Command unit

7.7 PV mode

PV(Profile speed control mode), specify the target speed, acceleration and deceleration, etc., and generate the speed control mode of position command action in the servo driver.

Please use this control mode in the communication cycle of more than 500 μ s.

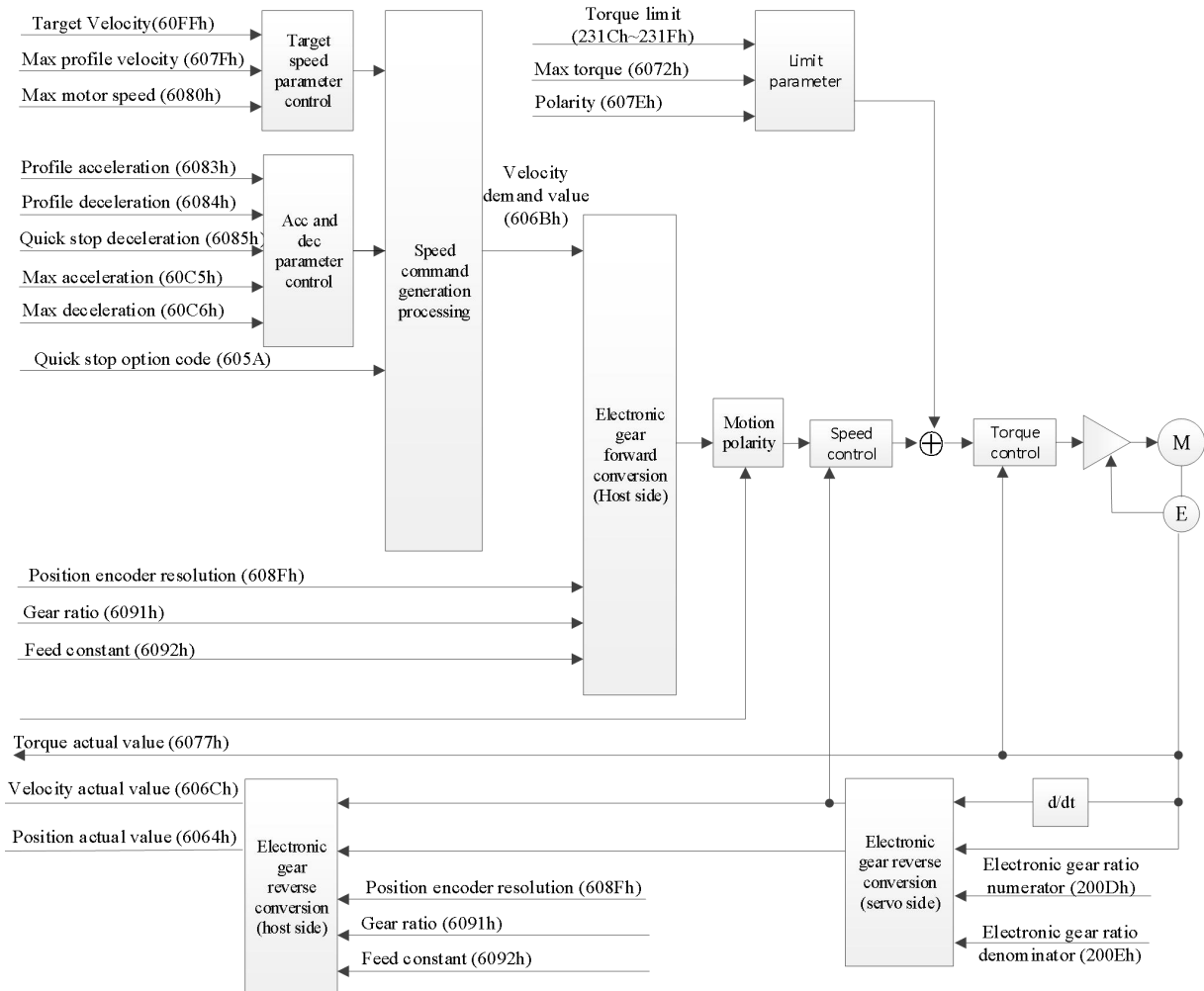

7.7.1 Related parameters

1)PV control mode related parameters(Command · setting)

Index	Sub-index	Name	Unit	Range	Data type	Access	PDO
6040h	00h	Controlword	-	0~65535	U16	rw	RxPDO
607Fh	00h	Max profile velocity	Command unit/s	0~4294967295	U32	rw	RxPDO
6083h	00h	Profile acceleration	Command unit/s ²	0~4294967295	U32	rw	RxPDO
6084h	00h	Profile deceleration	Command unit/s ²	0~4294967295	U32	rw	RxPDO
60C5h	00h	Max acceleration	Command unit/s ²	0~4294967295	U32	rw	RxPDO
60C6h	00h	Max deceleration	Command unit/s ²	0~4294967295	U32	rw	RxPDO

Other speed control common related objects

Index	Sub-index	Name	Unit	Range	Data type	Access	PDO
6072h	00h	Max torque	0.1%	0~65535	U16	rw	RxPDO
6080h	00h	Max motor	r/min	0~4294967295	U32	rw	RxPDO

60B1h	00h	speed Velocity offset	Command unit/s	-2147483648~2147483647	I32	rw	RxPDO
60B2h	00h	Torque offset	0.1%	-32768~32767	I16	rw	RxPDO
60FFh	00h	Target velocity	Command unit/s	0~4294967295	U32	rw	RxPDO

Other related objects with common actions

Index	Sub-index	Name	Unit	Range	Data type	Access	PDO
605Ah	00h	Quick stop option code	-	0~7	I16	rw	NO
605Bh	00h	Shutdown option code	-	0~1	I16	rw	NO
605Ch	00h	Diasble operation option code	-	0~1	I16	rw	NO
605Dh	00h	Halt option code	-	1~3	I16	rw	NO
605Eh	00h	Fault reaction option code	-	0~2	I16	rw	NO
607Bh	-	Position range limit	-	-	-	-	-
	00h	Numer of entries	-	2	U8	ro	NO
	01h	Min position limit	Command unit	-2147483648~2147483647	I32	rw	RxPDO
	02h	Max position limit	Command unit	-2147483648~2147483647	I32	rw	RxPDO
607Ch	00h	Home offset	Command unit	-2147483648~2147483647	I32	rw	RxPDO
607Eh	00h	Polarity	-	0~255	U8	rw	NO
6085h	00h	Quick stop deceleration	Command unit/s ²	0~4294967295	U32	rw	RxPDO
608Fh	-	Position encoder resolution	-	-	-	-	-
	00h	Number of entries	-	2	U8	ro	NO
	01h	Encoder increments	pulse	1~4294967295	U32	ro	NO
	02h	Motor revolutions	r(motor)	1~4294967295	U32	ro	NO
6091h	-	Gear ration	-	-	-	-	-
	00h	Number of entries	-	2	U8	ro	NO
	01h	Motor revolutions	r(motor)	1~4294967295	U32	ro	NO
	02h	shaft revolutions	r(shaft)	1~4294967295	U32	ro	NO
6092h	-	Feed constant	-	-	-	-	-
	00h	Highest sub-index supported	-	2	U8	ro	NO
	01h	Feed	Command unit	1~4294967295	U32	ro	NO
	02h	Shaft revolutions	r(shaft)	1~4294967295	U32	ro	NO
60B8h	00h	touch	-	0~65535	U16	rw	RxPDO

Controlword (6040h)< functions in pv control mode>

Index	Sub-index	Name	Range	Data type	access	PDO	Op-mode																																								
6040h	00h	Controlword	0~65535	U16	rw	RxPDO	All																																								
Set the control command to the servo driver such as PDS state conversion.																																															
Bit information																																															
<table border="1" style="width:100%; border-collapse: collapse;"> <tr> <td style="width:12.5%;">15</td> <td style="width:12.5%;">14</td> <td style="width:12.5%;">13</td> <td style="width:12.5%;">12</td> <td style="width:12.5%;">11</td> <td style="width:12.5%;">10</td> <td style="width:12.5%;">9</td> <td style="width:12.5%;">8</td> </tr> <tr> <td colspan="6" style="text-align:center;">r</td> <td style="text-align:center;">om</td> <td style="text-align:center;">h</td> </tr> <tr> <td style="text-align:center;">7</td> <td style="text-align:center;">6</td> <td style="text-align:center;">5</td> <td style="text-align:center;">4</td> <td style="text-align:center;">3</td> <td style="text-align:center;">2</td> <td style="text-align:center;">1</td> <td style="text-align:center;">0</td> </tr> <tr> <td style="text-align:center;">fr</td> <td colspan="3" style="text-align:center;">oms</td> <td style="text-align:center;">eo</td> <td style="text-align:center;">qs</td> <td style="text-align:center;">ev</td> <td style="text-align:center;">so</td> </tr> <tr> <td></td> <td style="text-align:center;">r</td> <td style="text-align:center;">r</td> <td style="text-align:center;">r</td> <td></td> <td></td> <td></td> <td></td> </tr> </table>								15	14	13	12	11	10	9	8	r						om	h	7	6	5	4	3	2	1	0	fr	oms			eo	qs	ev	so		r	r	r				
15	14	13	12	11	10	9	8																																								
r						om	h																																								
7	6	5	4	3	2	1	0																																								
fr	oms			eo	qs	ev	so																																								
	r	r	r																																												
r = reserved(not corresponding)				fr = fault reset																																											
oms = operation mode specific (control mode is based on bit)				eo = enable operation																																											
h = halt				qs = quick stop		ev = enable voltage																																									
				so = switch on																																											

Pv mode doesn't use oms bit.

Speed related parameters

Index	Sub-index	Name	Unit	Range	Data type	access	PDO	OP-mode
607Fh	00h	Max profile velocity	Command unit/s	0~4294967295	U32	rw	RxPDO	PP PV HM
		the speed limit value in profile position mode (PP), origin reset position mode (HM), profile speed mode (PV). The maximum value is limited by 6080h (max motor speed) for internal processing.						
6080h	00h	Max motor speed	r/min	0~4294967295	U32	rw	RxPDO	PV TQ CSV CST
		Set the maximum speed of the motor. When the control power is put into operation, the maximum speed read out from the motor is set. The maximum value is limited by the maximum speed read from the motor according to the internal processing. In TQ and CST, the speed is limited by the set value of this object.						

Acceleration and deceleration related parameters

Index	Sub-index	Name	Unit	Range	Data type	access	PDO	OP-mode
6083h	00h	Profile acceleration	Command unit/s ²	0~4294967295	U32	rw	RxPDO	PP PV
		Set profile acceleration. When set to 0, internal processing is treated as 1.						
6084h	00h	Profile deceleration	Command unit/s ²	0~4294967295	U32	rw	RxPDO	PP PV
		Set profile deceleration. When set to 0, internal processing is treated as 1.						
60C5h	00h	Max acceleration	Command unit/s ²	0~4294967295	U32	rw	RxPDO	PP PV HM
		Set the maximum acceleration. When set to 0, internal processing is treated as 1.						
60C6h	00h	Min deceleration	Command unit/s ²	0~4294967295	U32	rw	RxPDO	PP PV HM
		Set the maximum deceleration. When set to 0, internal processing is treated as 1.						

2)pv control mode related parameters(monitring)

Index	Sub-index	Name	Unit	Range	Data type	Access	PDO
6041h	00h	Statusword	-	0~65535	U16	ro	TxPDO
6065h	00h	Velocity window	Command unit/s	0~4294967295	U32	rw	RxPDO
6066h	00h	Velocity time out	1ms	0~65535	U16	rw	RxPDO
6067h	00h	Velocity threshold	Command unit/s	0~4294967295	U32	rw	RxPDO
6068h	00h	Velocity threshold time	1ms	0~65535	U16	rw	RxPDO

Other related objects with common speed control

Index	Sub-index	Name	Unit	Range	Data type	Access	PDO
6063h	00h	Position actual internal value	pulse	-2147483648~2147483647	I32	ro	TxPDO
6064h	00h	Position actual value	Command unit	-2147483648~2147483647	I32	ro	TxPDO

Index	Sub-index	Name	Unit	Range	Data type	Access	PDO
606Bh	00h	Velocity demand value	Command unit/s	-2147483648~2147483647	I32	ro	TxPDO
606Ch	00h	Velocity actual value	Command unit/s	-2147483648~2147483647	I32	ro	TxPDO
6074h	00h	Torque demand	0.1%	-32768~32767	I16	ro	TxPDO
6076h	00h	Motor rated torque	Mn·m	0~4294967295	U32	ro	TxPDO
6077h	00h	Torque actual value	0.1%	-32768~32767	I16	ro	TxPDO

Other related objects with common modes

Index	Sub-index	Name	Unit	Range	Data type	Access	PDO
603Fh	00h	Error code	-	0~65535	U16	ro	TxPDO
60B9h	00h	Touch probe status	-	0~65535	U16	ro	TxPDO
60BAh	00h	Touch probe pos1 pos value	Command unit	-2147483648~2147483647	I32	ro	TxPDO
60BBh	00h	Touch probe pos1 neg value	Command unit	-2147483648~2147483647	I32	ro	TxPDO
60BCh	00h	Touch probe pos2 pos value	Command unit	-2147483648~2147483647	I32	ro	TxPDO
60BDh	00h	Touch probe pos2 neg value	Command unit	-2147483648~2147483647	I32	ro	TxPDO

Statusword (6041h) <functions of pv control mode >

Index	Sub-index	Name/description	Range	Data type	Access	PDO	Op-mode
6041h	00h	Statusword	0~65535	U16	ro	TxPDO	All
Servo driver status							
Bit information							
15	14	13	12	11	10	9	8
r		oms		ila	oms		rm
		r	speed		Target reached		
7	6	5	4	3	2	1	0
w	sod	qs	ve	f	oe	so	rsto
r = reserved(not corresponding)				w = warning			
sod = switch on disabled				qs = quick stop			
oms = operation mode specific (control mode is based on bit)				ve = voltage enabled			
ila = internal limit active				f = fault			
oe = operation enabled							
rm = remote				so = switched on			
rtso = ready to switch on							

(1)bit10(target reached(Velocity reached)):

The difference between the total value of 60FFh (target velocity) and 60B1h (velocity offset) and 606Ch (velocity actual value) is within the range set by 606Dh (velocity window). If the time set by 606Eh (velocity window time) passes, the bit10 of 6041h (status word) becomes 1.

Bit	Name	Value	Definition
10	Target reached	0	Halt = 0 (normal): speed control not completed Halt = 1 (stop according to halt): shaft in deceleration
		1	Halt = 0 (normal): speed control completed Halt = 1 (according to halt stop): shaft stop (shaft speed is 0)

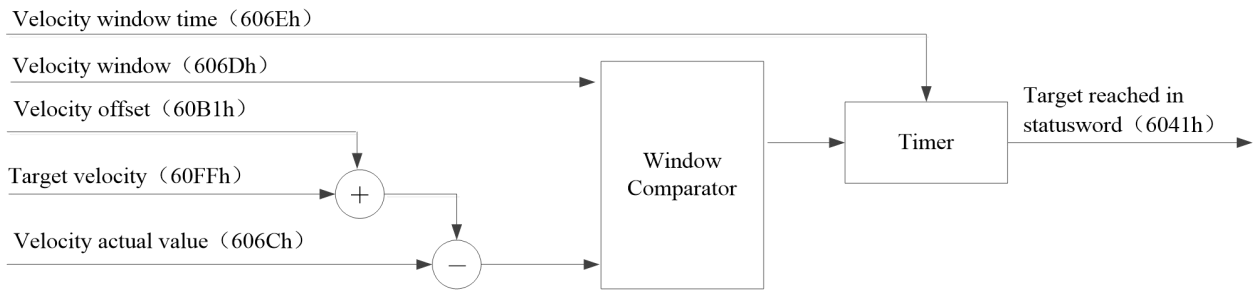

Index	Sub-index	Name	Unit	Range	Data type	Access	PDO	OP-mode
606Dh	00h	Velocity window	Command unit	0~4294967295	U32	rw	RxPDO	PV
		The difference between the total value of 60FFh (target velocity) and 60B1h (velocity offset) and 606Ch (velocity actual value) is within the set value of this parameter. If the time set by 606Eh (velocity window time) passes, set the bit10 (target reached) of 6041h (status word) to 1 as the threshold value. If the speed deviation is a value other than the set value of this parameter, bit10 of 6041h becomes 0.						
606Eh	00h	Velocity window time	1ms	0~65535	U16	rw	RxPDO	PV
		Set the time from the point when the difference between the sum of 60FFh(target velocity) and 60B1h (velocity offset),and 606Ch(velocity actual value),fall within the range set by 606Dh (Velocity window) to bit10 (target reached) of 6041h (Statusword) becomes 1.						

(2)bit12(speed)

When 606Ch (Velocity actual value) exceeds the value set in 606Fh (Velocity threshold) and the time set by 6070h (Velocity threshold time) has elapsed, bit 12 of 6041h (Statusword) changes to 0.

When 606Ch (Velocity actual value) becomes lower than the value set in 606Fh (Velocity threshold), bit12 of 6041h (Statusword) changes to 1, which indicates that the motor has stopped.

Bit	Name	Value	definition
10	speed	0	Motor is operating
		1	Motor is not operating

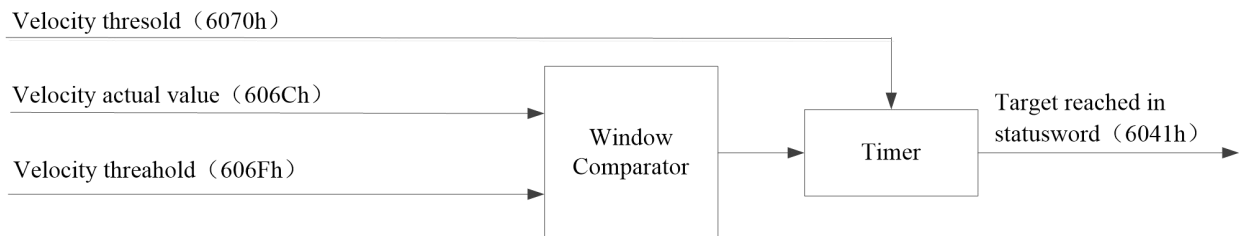

< Speed (functional overview) >

Index	Sub-index	Name	Unit	Range	Data type	Access	PDO	OP-mode
606Fh	00h	Velocity threshold	Command unit	0~4294967295	U32	rw	RxPDO	PV
		Set the threshold where bit 12 (speed) of 6041h (Statusword) becomes 0 when 606Ch (Velocity actual value) exceeds the value set to this parameter and the time set in 6070h (Velocity threshold time) has elapsed. When the velocity becomes the value set in this parameter or less, bit 12 of 6041 (Statusword) changes to 1.						
6070h	00h	Velocity threshold time	1ms	0~65535	U16	rw	RxPDO	PV
		Set the time from the point when 606Ch (Velocity actual value) exceeds the value set to 606Fh (Velocity threshold) until the point when bit 12 of 6041h (Statusword) changes to 0.						

3) PV operations

- ◆ Profile velocity control mode generates a velocity command value according to the following parameters
- ◆ Target velocity(60FFh)
- ◆ Velocity offset(60B1h)
- ◆ Profile acceleration(6083h)
- ◆ Profile deceleration(6084h)
- ◆ Target speed is 60FFh(Target velocity)
- ◆ Speed feedforward is 60B1h(Velocity offset) cannot support now
- ◆ The update (sending) of action command is that after the servo enable is turned on, please input it after about 100ms.
- ◆ As test information, provide 606Ch (velocity actual value), etc.

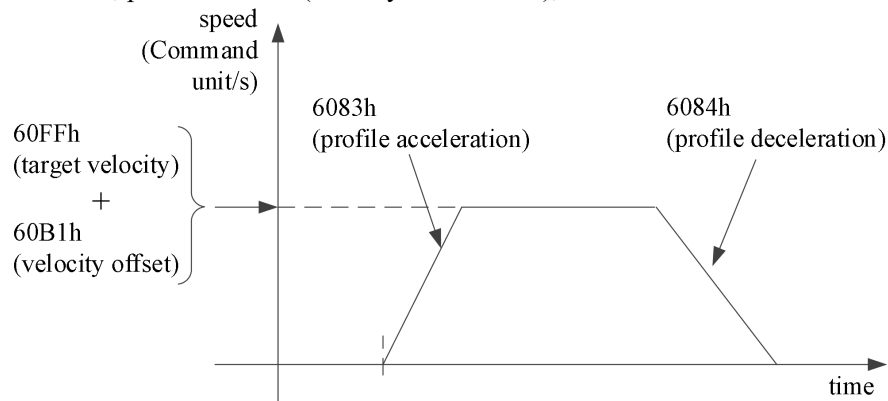

- ◆ The 60FFh (target velocity) is limited by 607Fh (max profile velocity) and 6080h (max motor speed).

7.7.2 Common parameters

PV control mode related objects(Command · setting)

Register	Explanation	Unit
RXPDO[0x6040]	Controlword	-
RXPDO[0x6060]	Set to 3	-
RXPDO[0x60FF]	Target velocity	Command unit/s
RXPDO[0x6072]	Max torque	0.1%
RXPDO[0x607F]	Max profile velocity	Command unit/s
RXPDO[0x6080]	Max motor speed	r/min
RXPDO[0x6083]	Profile acceleration	Command unit/s ²
RXPDO[0x6084]	Profile deceleration	Command unit/s ²
RXPDO[0x60C5]	Max acceleration	Command unit/s ²
RXPDO[0x60C6]	Max deceleration	Command unit/s ²
RXPDO[0x606D]	Velocity window	Command unit/s
RXPDO[0x606E]	Velocity window time	ms
RXPDO[0x606F]	Velocity threshold	Command unit/s
RXPDO[0x6070]	Velocity threshold time	ms

PV control mode related objects(Command · monitoring)

Register	Explanation	Unit
TXPDO[0x6041]	Statusword	-
TXPDO[0x6064]	Position actual value	Command unit
TXPDO[0x606C]	Velocity actual value	Command unit/s
TXPDO[0x6077]	Torque actual value	0.1%

7.8 TQ mode

TQ(Profile torque mode),specify target torque, acceleration and deceleration,etc.,this torque control mode after generating position command in servo driver. Please use this control mode in the communication period of more than 500 μ s.

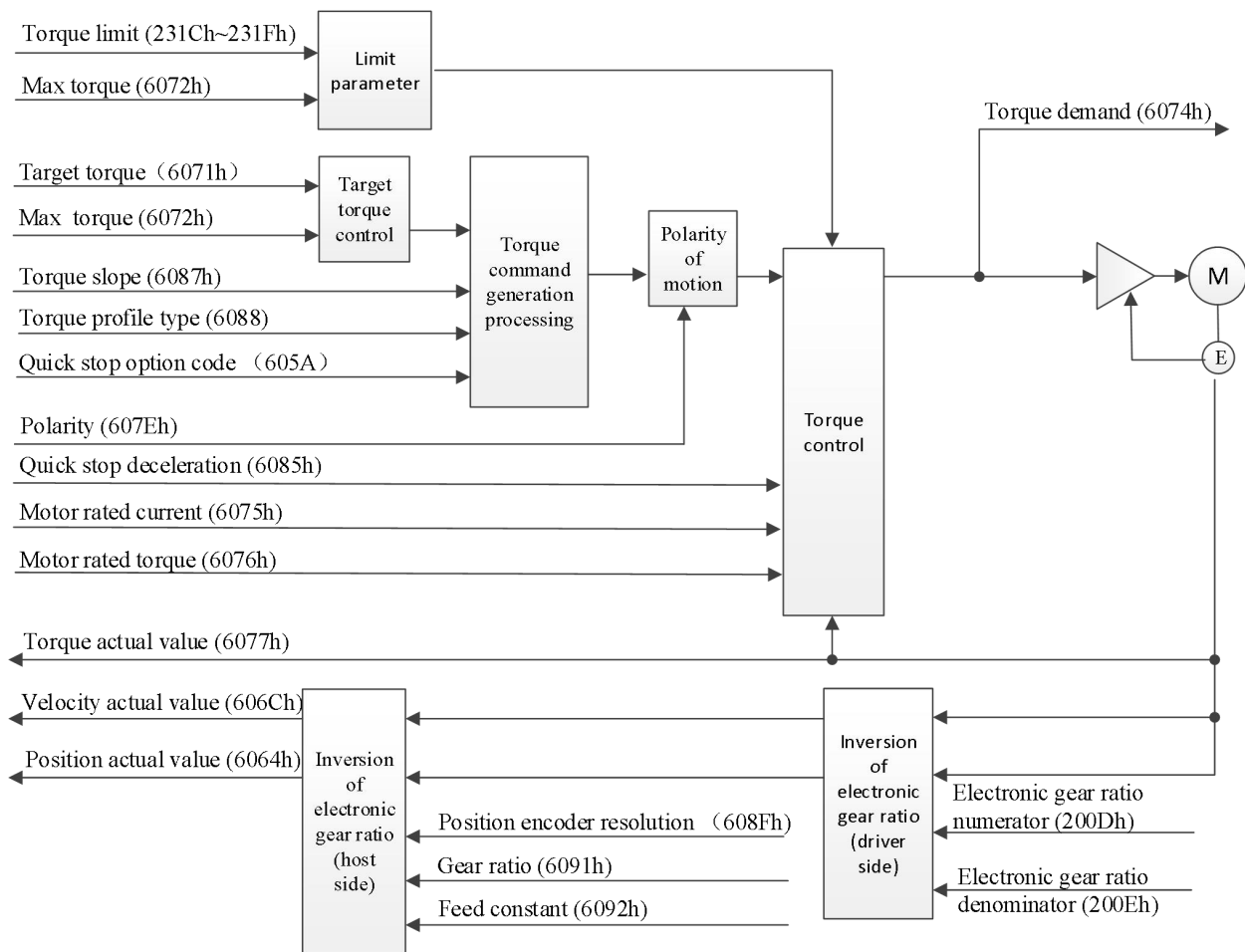

7.8.1 Related parameters

1)TQ control mode related objects(Command · setting)

Index	Sub-index	Name	Unit	Range	Data type	Access	PDO
6040h	00h	Controlword	-	0~65535	U16	rw	RxPDO
6088h	00h	Torque profile type	-	-32768~32767	I16	rw	RxPDO

Other related objects that are common to torque control

Index	Sub-index	Name	Unit	Range	Data type	Access	PDO
6071h	00h	Target torque	0.1%	-3276~32767	I16	rw	RxPDO
6072h	00h	Max torque	0.1%	0~65535	U16	rw	RxPDO
6080h	00h	Max motor speed	r/min	0~4294967295	U32	rw	RxPDO
6087h	00h	Torque slope	0.1%/S	0~4294967295	U32	rw	RxPDO
60B2h	00h	Torque offset	0.1%	-32768~32767	I16	rw	RxPDO

Other related objects with common actions

Index	Sub-index	Name	Unit	Range	Data type	Access	PDO
605Ah	00h	Quick stop option code	-	0~7	I16	rw	NO
605Bh	00h	Shutdown option code	-	0~1	I16	rw	NO
605Ch	00h	Disable operation option code	-	0~1	I16	rw	NO
605Dh	00h	Halt option code	-	1~3	I16	rw	NO

Index	Sub-index	Name	Unit	Range	Data type	Access	PDO
605Eh	00h	Fault reaction option code	-	0~2	I16	rw	NO
607Bh	-	Position range limit	-	-	-	-	-
	00h	Number of entries	-	2	U8	ro	No
	01h	Min position limit	Command unit	-2147483648~2147483647	I32	rw	RxPDO
	02h	Max position limit	Command unit	-2147483648~2147483647	I32	rw	RxPDO
607Ch	00h	Home offset	Command unit	-2147483648~2147483647	I32	rw	RxPDO
607Eh	00h	Polarity	-	0~255	U8	rw	NO
6085h	00h	Quick stop deceleration	Command unit/s ²	0~4294967295	U32	rw	RxPDO
6086h	00h	Motion profile type	-	-32768~32767	I16	rw	RxPDO
608Fh	-	Position encoder resolution	-	-	-	-	-
	00h	Number of entries	-	2	U8	ro	NO
	01h	Encoder increments	pulse	1~4294967295	U32	ro	NO
	02h	Motor revolutions	r(motor)	1~4294967295	U32	ro	NO
6091h	-	Gear ratio	-	-	-	-	-
	00h	Number of entries	-	2	U8	ro	NO
	01h	Motor revolutions	r(motor)	1~4294967295	U32	ro	NO
	02h	Shaft revolutions	r(shaft)	1~4294967295	U32	ro	NO
6092h	-	Feed constant	-	-	-	-	-
	00h	Number of entries	-	2	U8	ro	NO
	01h	Feed	Command unit	1~4294967295	U32	ro	NO
	02h	Shaft revolutions	r(shaft)	1~4294967295	U32	ro	NO
60B8h	00h	Touch probe function	-	0~65535	U16	rw	RxPDO

Controlword (6040h) < functions in TQ control mode >

Index	Sub-index	Name	Range	Data type	Access	PDO	Op-mode																																			
6040h	00h	Controlword	0~65535	U16	rw	RxPDO	All																																			
Set the control command to the servo driver such as PDS state conversion.																																										
Bit information																																										
<table border="1" style="width:100%; border-collapse: collapse;"> <thead> <tr> <th>15</th> <th>14</th> <th>13</th> <th>12</th> <th>11</th> <th>10</th> <th>9</th> <th>8</th> </tr> </thead> <tbody> <tr> <td colspan="6" style="text-align:center;">R</td> <td>om</td> <td>h</td> </tr> <tr> <th>7</th> <th>6</th> <th>5</th> <th>4</th> <th>3</th> <th>2</th> <th>1</th> <th>0</th> </tr> <tr> <td rowspan="2" style="text-align:center;">fr</td> <td colspan="3" style="text-align:center;">oms</td> <td rowspan="2" style="text-align:center;">eo</td> <td rowspan="2" style="text-align:center;">qs</td> <td rowspan="2" style="text-align:center;">ev</td> <td rowspan="2" style="text-align:center;">so</td> </tr> <tr> <td style="text-align:center;">r</td> <td style="text-align:center;">r</td> <td style="text-align:center;">r</td> </tr> </tbody> </table>								15	14	13	12	11	10	9	8	R						om	h	7	6	5	4	3	2	1	0	fr	oms			eo	qs	ev	so	r	r	r
15	14	13	12	11	10	9	8																																			
R						om	h																																			
7	6	5	4	3	2	1	0																																			
fr	oms			eo	qs	ev	so																																			
	r	r	r																																							
r = reserved(not corresponding)				fr = fault reset																																						
oms = operation mode specific (control mode is based on bit)				eo = enable operation																																						
h = halt				qs = quick stop																																						
so = switch on				ev = enable voltage																																						

TQ mode doesn't use oms bit.

Torque type

Index	Sub-index	Name	Unit	Range	Data type	access	PDO	OP-mode
6087h	00h	Torque slope	0.1 %	0~4294967295	U32	rw	RxPDO	tq cst
		<ul style="list-style-type: none"> Set a parameter value for giving slope to a torque command. In the cyclic synchronous torque mode (cst), torque slope is effective only during the deceleration stop sequence. When 0 has been set, the setting is regarded as 1 internally. 						
6088h	00h	Torque profile type	-	-32768~32767	I16	rw	RxPDO	tq
		Set the torque profile type used for changing in the torque 0:linear slope 1:Not supported						

2)TQ control mode related objects(monitring)

Index	Sub-index	Name	Unit	Range	Data type	Access	PDO
6041h	00h	Statusword	-	0~65535	U16	ro	TxPDO
6073h	00h	Max current	0.1%	0~65535	U16	ro	NO

Other objects commonly associated with torque control (monitoring)

Index	Sub-index	Name	Unit	Range	Data type	Access	PDO
6063h	00h	Position actual internal value	pulse	-2147483648~2147483647	I32	ro	TxPDO
6064h	00h	Position actual value	Command unit	-2147483648~2147483647	I32	ro	TxPDO
606Ch	00h	Velocity actual value	Command unit/s	-2147483648~2147483647	I32	ro	TxPDO
6074h	00h	Torque demand	0.1%	-32768~32767	I16	ro	TxPDO
6075h	00h	Motor rated current	1mA	0~4294967295	U32	ro	TxPDO
6076h	00h	Motor rated torque	Mn·m	0~4294967295	U32	ro	TxPDO
6077h	00h	Torque actual value	0.1%	-32768~32767	I16	ro	TxPDO
6078h	00h	Current actual value	0.1%	-32768~32767	I16	ro	TxPDO

Other associated objects that share the same mode

Index	Sub-index	Name	Unit	Range	Data type	access	PDO
603Fh	00h	Error code	-	0~65535	U16	ro	TxPDO
60B9h	00h	Touch probe status	-	0~65535	U16	ro	TxPDO
60BAh	00h	Touch probe pos1 pos value	Command unit	-2147483648~2147483647	I32	ro	TxPDO
60BBh	00h	Touch probe pos1 neg value	Command unit	-2147483648~2147483647	I32	ro	TxPDO
60BCh	00h	Touch probe pos2 pos value	Command unit	-2147483648~2147483647	I32	ro	TxPDO
60BDh	00h	Touch probe pos2 neg value	Command unit	-2147483648~2147483647	I32	ro	TxPDO

Statusword (6041h) < functions of TQ control mode >

Index	Sub-index	Name	Range	Data type	Access	PDO	Op-mode																																								
6041h	00h	Statusword	0~65535	U16	ro	TxPDO	All																																								
Servo driver status Bit information <table border="1" style="width:100%; border-collapse: collapse;"> <thead> <tr> <th>15</th> <th>14</th> <th>13</th> <th>12</th> <th>11</th> <th>10</th> <th>9</th> <th>8</th> </tr> </thead> <tbody> <tr> <td colspan="2" style="text-align:center">r</td> <td colspan="2" style="text-align:center">oms</td> <td style="text-align:center">ila</td> <td style="text-align:center">oms</td> <td style="text-align:center">rm</td> <td style="text-align:center">r</td> </tr> <tr> <td colspan="2"></td> <td style="text-align:center">r</td> <td style="text-align:center">r</td> <td colspan="2" style="text-align:center">target reached</td> <td colspan="2"></td> </tr> <tr> <th>7</th> <th>6</th> <th>5</th> <th>4</th> <th>3</th> <th>2</th> <th>1</th> <th>0</th> </tr> <tr> <td style="text-align:center">w</td> <td style="text-align:center">sod</td> <td style="text-align:center">qs</td> <td style="text-align:center">ve</td> <td style="text-align:center">f</td> <td style="text-align:center">oe</td> <td style="text-align:center">so</td> <td style="text-align:center">rsto</td> </tr> </tbody> </table> r = reserved(not corresponding) w = warning sod = switch on disabled oms = operation mode specific qs = quick stop (Control mode is based on bit) ve = voltage enabled ila = internal limit active f = fault oe = operation enabled so = switched on rm = remote rsto = ready to switch on								15	14	13	12	11	10	9	8	r		oms		ila	oms	rm	r			r	r	target reached				7	6	5	4	3	2	1	0	w	sod	qs	ve	f	oe	so	rsto
15	14	13	12	11	10	9	8																																								
r		oms		ila	oms	rm	r																																								
		r	r	target reached																																											
7	6	5	4	3	2	1	0																																								
w	sod	qs	ve	f	oe	so	rsto																																								

bit13,12,10(operation mode specific):

Bit	Name	Value	Definition
10	Target reached	0	halt=0 (normal): 6074h (Torque demand) not reach the target torque halt=1 (stop as halt): shaft is decelerating
		1	halt=0 (normal): 6074h (Torque demand) reach the target torque halt=1 (stop as halt): shaft stops (shaft speed is 0)
12	reserved	-	Not used

Bit	Name	Value	Definition
13	reserved	-	Not used

Action of TQ control mode

- ◆ The profile torque control mode generates torque command values based on the following parameters.
- ◆ Target torque(6071h)
- ◆ Torque offset(60B2h)(cannot support)
- ◆ Torque slope(6087h)
- ◆ For the operation command update(transmission),do input when approx 100ms has elapsed after the servo ON(operation enabled command)
- ◆ As monitoring information,we provide 6077h(Torque actual value) etc.

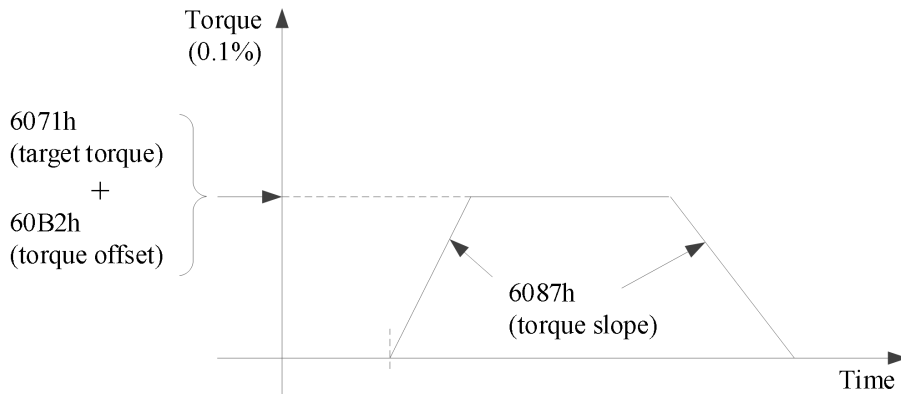

- ◆ The 6071h (target torque) value is 6072h (max torque), 2312h (P3-28), 2313h (P3-29), which is limited by the minimum value.
- ◆ The speed is limited by 6080h (max motor speed).

7.8.2 Common parameters

TQ control mode related objects(Command · setting)

Register	Explanation	Unit
RXPDO[0x6040]	Controlword	-
RXPDO[0x6060]	Set to 4	-
RXPDO[0x6071]	Target torque	0.1%
RXPDO[0x6072]	Max torque	0.1%
RXPDO[0x6080]	Max motor speed	r/min
RXPDO[0x6087]	Torque slope	0.1%/S
RXPDO[0x6088]	Torque Profile type	-

TQ control mode related objects(Command · monitoring)

Register	Explanation	Unit
TXPDO[0x6041]	Statusword	-
TXPDO[0x6064]	Position actual value	Command unit
TXPDO[0x606C]	Velocity actual value	Command unit/s
TXPDO[0x6077]	Torque actual value	0.1%

TQ mode does not use oms bit.

7.9 Mode common function

7.9.1 Mode mutual switching function

3791 and later versions support mode switching during runtime, with a mode switching time of 2ms. In the servo enabled state, it supports position mode switching to speed mode, position mode switching to torque mode, and speed mode switching to torque mode, making it convenient for users to achieve multi-mode switching control in project engineering.

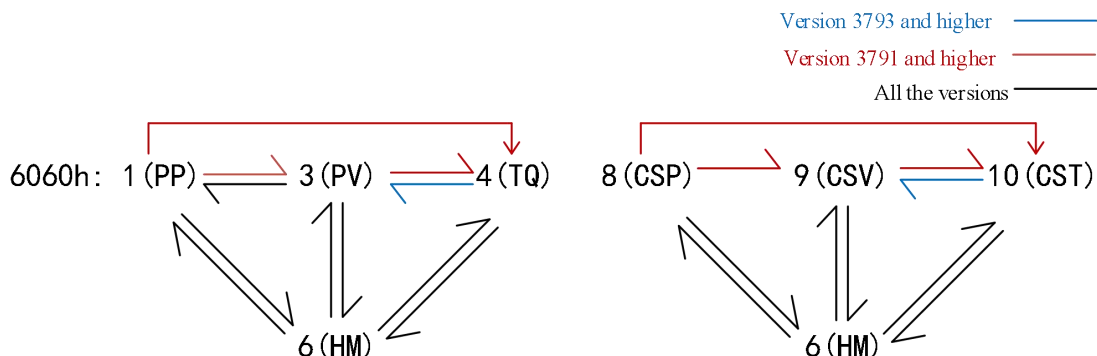

7.9.2 Stop mode

PDS is a motor deceleration stop method for setting the main power supply interruption or alarm occurrence in the operation enabled state (servo enabled state).

The deceleration function (selection code) defined by COE (CIA402) and the deceleration function (free running stop, deceleration stop) on the servo (DS5C1) side are combined.

PDS code list

Index	Sub-index	Name	Unit	Range	Data type	Access	PDO
605Ah	00h	Quick stop option code	-	0~7	I16	rw	NO
605Bh	00h	Shutdown option code	-	0~1	I16	rw	NO
605Ch	00h	Disable operation option code	-	0~1	I16	rw	NO
605Dh	00h	Halt option code	-	1~3	I16	rw	NO
605Eh	00h	Fault reaction option code	-	0~2	I16	rw	NO

Related object list

Index	Sub-index	Name	Unit	Range	Data type	Access	PDO	OP-mode
6084h	00h	Profile deceleration	Command unit/s ²	0~4294967295	U32	rw	RxPDO	PP PV HM CSP CSV
		Set profile deceleration. When set to 0, internal processing is treated as 1.						
6085h	00h	Quick stop deceleration	Command unit/s ²	0~4294967295	U32	rw	RxPDO	PP PV HM CSP CSV
		<ul style="list-style-type: none"> If 605Ah (Quick stop option code) is "2" or "6", set the deceleration parameter of motor deceleration stop when quick stop. 605Dh (Halt option code) and 605Eh (Fault reaction option code) are also used when they are "2". 						
6087h	00h	Torque slope	0.1%	0~4294967295	U32	rw	RxPDO	TQ CST

Index	Sub-index	Name	Unit	Range	Data type	Access	PDO	OP-mode	
		<ul style="list-style-type: none"> Set the parameter value to give the inclination torque command. Only deceleration stop time is valid in cyclic synchronous torque mode (CST). 							
609Ah	00h	Homing acceleration	Command unit/s ²	0~4294967295	U32	rw	RxPDO	HM	
		<ul style="list-style-type: none"> Set the acceleration and deceleration of the origin point reset position control mode (HM). The deceleration of the origin reset position control mode (HM) is also used for this object. when each homing method finally stops(when the origin position is detected), it is unnecessary to use the set value of this object, and the servo lock stops. 							
60C6h	00h	Max deceleration	Command unit/s ²	0~4294967295	U32	rw	RxPDO	PP HM CSP	
		<ul style="list-style-type: none"> Set the maximum deceleration. If it is set to 0, internal processing is operated as 1. 							

1) Quick stop option code (605Ah)

Set the motor deceleration stop method when PDS command [Quick stop] is received.

Index	Sub-index	Name	Unit	Range	Data type	Access	PDO	OP-mode	
		Quick stop option code	-	0~7	I16	rw	NO	ALL	
605Ah	00h	<p>pp,csp, csv,pv</p> <p>0: after motor stop through servo side (Sequence at Servo-off), migrate to Switch on disabled.</p> <p>1: after motor stop through 6084h (Profile deceleration), migrate to Switch on disabled.</p> <p>2: after motor stop through 6085h (Quick stop deceleration), migrate to Switch on disabled.</p> <p>3: after motor stop through 60C6h (Max deceleration), migrate to Switch on disabled.</p> <p>5: after motor stop through 6084h (Profile deceleration), migrate to Quick stop active.</p> <p>6: after motor stop through 6085h (Quick stop deceleration), migrate to Quick stop active.</p> <p>7: after motor stop through 60C6h (Max deceleration), migrate to Quick stop active.</p> <p>hm</p> <p>0: after motor stop through (Sequence at Servo-off), migrate to Switch on disabled.</p> <p>1: after motor stop through 609Ah (Homing acceleration), migrate to Switch on disabled.</p> <p>2: after motor stop through 6085h (Quick stop deceleration), migrate to Switch on disabled.</p> <p>3: after motor stop through 60C6h (Max deceleration), migrate to Switch on disabled.</p> <p>5: after motor stop through 609Ah (Homing acceleration), migrate to Quick stop active.</p> <p>6: after motor stop through 6085h (Quick stop deceleration), migrate to Quick stop active.</p> <p>7: after motor stop through 60C6h (Max deceleration), migrate to Quick stop active.</p> <p>cst, tq</p> <p>0: after motor stop through servo side (Sequence at Servo-off), migrate to Switch on disabled.</p> <p>1, 2: after motor stop through 6087h (Torque slope), migrate to Switch on disabled.</p> <p>3: after motor stop through torque 0, migrate to Switch on disabled.</p> <p>5, 6: after motor stop through 6087h (Torque slope), migrate to Quick stop active.</p> <p>7: after motor stop through torque 0, migrate to Quick stop active.</p>							

Deceleration stop examples according to the Quick stop command:

A: if 6040h: bit2 (control word: quick stop) changes from 1 to 0, it starts to slow down and stop.

The PDS status in deceleration changes to quick stop active.

B: the motor stops when the actual speed is less than 10r / min.

The PDS status after stopping is switch on disabled, or it changes to quick stop active.

2) Shutdown option code (605Bh)

Set the motor deceleration stop method when PDS command [Shutdown] and [Disable voltage] are received.

Index	Sub-index	Name	Units	Range	Data type	Access	PDO	OP-mode
605Bh	00h	Shutdown option code	-	0~1	I8	rw	RxPDO	ALL
		<p>Set the timing when PDS command [shutdown] and [disable voltage] are received. It is different according to the definition of control mode. The settings except the following values are not allowed.</p> <p>(1) receiving PDS command 「Shutdown」</p> <p>pp, csp, csv, pv 0: after motor stop through servo side (Sequence at Servo-off), migrate to Ready to switch on. 1: after motor stop through 6084h (Profile deceleration), migrate to Ready to switch on.</p> <p>hm 0: after motor stop through servo side (Sequence at Servo-off), migrate to Ready to switch on. 1: after motor stop through 609Ah (Homing acceleration), migrate to Ready to switch on.</p> <p>cst, tq 0: after motor stop through servo side (Sequence at Servo-off), migrate to Ready to switch on. 1: after motor stop through 6087h (Torque slope), migrate to Ready to switch on.</p> <p>(2) receiving PDS command 「Disable voltage」</p> <p>pp, csp, csv, pv 0: after motor stop through servo side (Sequence at Servo-off), migrate to Switch on disabled. 1: after motor stop through 6084h (Profile deceleration), migrate to Switch on disabled.</p> <p>hm 0: after motor stop through servo side (Sequence at Servo-off), migrate to Switch on disabled. 1: after motor stop through 609Ah (Homing acceleration), migrate to Switch on disabled.</p> <p>cst, tq 0: after motor stop through servo side (Sequence at Servo-off), migrate to Switch on disabled. 1: after motor stop through 6087h (Torque slope), migrate to Switch on disabled.</p>						

The slowing down stop examples according to shutdown command:

A: if receiving PDS command "shutdown" to deceleration stop.

PDS status in deceleration remains operation enabled.

B: the motor stops when the actual speed is less than 10r / min.

The PDS status after stopping is Ready to switch on.

3) Disable operation option code(605Ch)

Set the motor deceleration stop method when receiving the PDS command 「Disable operation」 .

Index	Sub-index	Name	Units	Range	Datatype	Access	PDO	OP-mode
605Ch	00h	Disable operation option code	-	0~1	I8	rw	RxPDO	ALL
		<p>Set the timing when PDS command [disable operation] is received. It is different according to the definition of control mode. The settings except the following values are not allowed.</p> <p>pp, csp, csv, pv 0: after motor stop through servo side (Sequence at Servo-off), migrate to Switched on. 1: after motor stop through 6084h (Profile deceleration), migrate to Switched on.</p> <p>hm 0: after motor stop through servo side (Sequence at Servo-off), migrate to Switched on.</p>						

		1: after motor stop through 609Ah (Homing acceleration), migrate to Switched on. cst, tq 0: after motor stop through servo side (Sequence at Servo-off), migrate to Switched on. 1: after motor stop through 6087h (Torque slope), migrate to Switched on.
--	--	---

The slowing down stop examples according to Disable operation command:

A: if receiving PDS command "Disable operation" to deceleration stop.

PDS status in deceleration remains operation enabled.

B: the motor stops when the actual speed is less than 10r / min.

The PDS status after stop is Switched on.

4) Halt option code(605Dh)

Set motor decelerating stop method when bit8 of 6040h(controlword)is 1.

Index	Sub-index	Name	Units	Range	Data type	Access	PDO	OP-mode
605Dh	00h	Halt option code	-	1~3	I16	rw	NO	ALL
		Set the timing when PDS command [disable operation] is received. It is different according to the definition of control mode. • set the timing of Halt action. It is different according to the definition of control mode. The settings except the following values are not allowed. pp, csp, csv, pv 1: after motor stop through 6084h (Profile deceleration), keep Operation enabled. 2: after motor stop through 6085h (Quick stop deceleration), keep Operation enabled. 3: after motor stop through 6072h (Max torque), 60C6h (Max deceleration) keeps Operation enabled. hm 1: after motor stop through 609Ah (Homing acceleration), keep Operation enabled. 2: after motor stop through 6085h (Quick stop deceleration), keep Operation enabled. 3: after motor stop through 6072h (Max torque), 60C6h(Max deceleration), keep Operation enabled. cst, tq 1, 2: after motor stop through 6087h (Torque slope), keep Operation enabled. 3: after motor stop through torque 0, keep Operation enabled.						

Examples of slowing down and stop according to the halt function

A: if 6040h: bit8 (control word: halt) changes from 0 to 1, it deceleration stops. PDS status in deceleration remains operation enabled.

B: the motor stops when the actual speed is less than 10 r/min. The PDS state after stop remains operation enabled.

5) Fault reaction option code(605Eh)

Set the motor stop method when alarm occurs.

Index	Sub-index	Name	Units	Range	Data type	Access	PDO	OP-mode
605Eh	00h	Fault reaction option code	-	0~2	I16	rw	NO	ALL
		Set the timing when the alarm occurs. It is different according to the definition of control mode. The settings except the following values are not allowed. (1) When the Err80.0~80.7, 81.0~81.7, 85.0~85.7, 88.0~88.7 occurred pp, csp, csv, pv 0: after motor stop through servo side (Sequence at alarm), migrate to Fault. 1: after motor stop through 6084h (Profile deceleration), migrate to Fault. 2: after motor stop through 6085h (Quick stop deceleration), migrate to Fault. hm 0: after motor stop through servo side (Sequence at alarm), migrate to Fault.						

	<p>1: after motor stop through 609Ah (Homing acceleration), migrate to Fault. 2: after motor stop through 6085h (Quick stop deceleration), migrate to Fault. cst, tq 0: after motor stop through servo side (Sequence at alarm), migrate to Fault. 1, 2: after motor stop through 6087h (Torque slope), migrate to Fault.</p> <p>(2) alarm except above (1) listed occurred 0, 1, 2: after motor stop through servo side (Sequence at alarm), migrate to Fault.</p>
--	--

Deceleration stop examples according to alarm

A: if there is an alarm, it starts to slow down and stop. PDS status in deceleration is Fault reaction active.

B: the motor stops when the actual speed is less than 10 r / min. PDS status after stop is Fault.

7.9.3 Touch Probe function(position clamp request/release)

The probe function is the position locking function. When the trigger condition (EXT1 / EXT2) is met, the probe function is triggered and the motor encoder value when the condition is triggered is locked. According to the setting of probe control word 60B8, single or multiple triggering can be realized.

Note:

(1) Probe function is not supported in HM mode.

(2) Currently, only external signals are supported as trigger sources.

1) Touch probe function composition

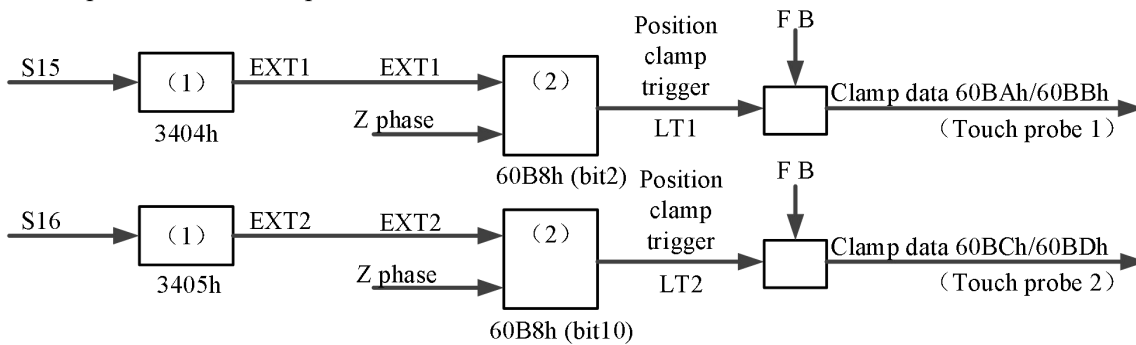

60B8h:Touch probe function

60BAh:Touch probe pos1 pos value

60BBh:Touch probe pos1 neg value

60BCh:Touch probe pos2 pos value

60BDh:Touch probe pos2 neg value

If the trigger position is at the same point of one rotation of the motor, theoretically, the difference between the two latched probe values shall be the number of pulses sent by the motor encoder for one rotation.

It should be noted that it takes a certain time from the generation of the external trigger signal to the driver receiving the signal and performing the latch operation. Therefore, the latch value of the probe must have an error with the actual value. The error is related to the motor speed, hardware performance and software processing.

Notes for function use:

Product model	Power	Default value		Set when using probe function	
		P5-62	P5-63	P5-62 (terminal)	P5-63 (terminal)
DS5C1	20P1, 2P2, 20P4, 20P7	0	0	1 (SI1)	2 (SI2)
	21P0, 21P5, 22P3, 22P6 41P0, 41P5, 42P3, 43P0	0	0	4 (SI4)	5 (SI5)
	411P0, 415P0	0 (3791 and higher) 5 (before 3791)	0 (3791 and higher) 6 (before 3791)	6 (P-)	7 (D-)

422P0, 432P0	0 (3793 and higher) 5 (before 3793)	0 (3793 and higher) 6 (before 3793)	6 (P-)	7 (D-)
--------------	--	--	--------	--------

(1) The clamping trigger signal uses external inputs (EXT1/EXT2), and P5-62 and P5-63 are terminal assignment parameters for Touch Probe1 and Touch Probe2 functions. The default parameters for the driver probe function are shown in the table above.

60B8h (Touch probe function)			
Bit10	LT2	Bit2	LT1
0	EXT2	0	EXT1
1	Z phase	1	Z phase

- (2) if the touch probe is executed to an unassigned port, E-883 (abnormal action protection) will occur.
(3) when the clamping trigger signal is an external input (EXT1/EXT2), the acquisition error occurs. Make the speed near the clamp signal input as low as possible.
(4) the width of input ON and OFF of clamping trigger signal shall be more than 2ms respectively.
(5) in the following cases, touch probe is invalid (cancelled). (the value of 60B9h is cleared).
① when ESM status is init
② switch to HM mode
(6) for the same touch probe, please do not set the rising edge and the falling edge at the same time. The action of setting the situation at the same time is unknown.
(7) it should be noted that it takes a certain time from the generation of external trigger signal to the reception of signal by driver and the execution of latch operation. Therefore, the value of probe latch must have error with the actual value, and the difference is related to the motor speed, hardware performance and software processing.

2) Touch probe objects

Index	Sub-index	Name	Units	Range	Data type	Access	PDO
60B8h	00h	Touch probe function	-	0~65535	U16	rw	RxPDO
60B9h	00h	Touch probe status	-	0~65535	U16	ro	TxPDO
60BAh	00h	Touch probe pos1 pos value	Command unit	-2147483648~ 2147483647	I32	ro	TxPDO
60BBh	00h	Touch probe pos1 neg value	Command unit	-2147483648~ 2147483647	I32	ro	TxPDO
60BCh	00h	Touch probe pos2 pos value	Command unit	-2147483648~ 2147483647	I32	ro	TxPDO
60BDh	00h	Touch probe pos2 neg value	Command unit	-2147483648~ 2147483647	I32	ro	TxPDO

3) Touch probe function (60B8h)

Index	Sub-index	Name	Units	Range	Data type	Access	PDO	OP-mode
60B8h	00h	Touch probe function	-	0~65535	U16	rw	RxPDO	ALL
		Execute the function setting of Touch probe.						

Related bit information

bit	Value	Note
0	0	Switch off touch probe 1
	1	Enable touch probe 1
1	0	Trigger first event
	1	Continuous
2	0	Trigger with touch probe 1 input
	1	Trigger with zero impulse signal of position encoder
3	-	Reserved
4	0	Switch off sampling at positive edge of touch probe 1
	1	Enable sampling at positive edge of touch probe 1
5	0	Switch off sampling at negative edge of touch probe 1
	1	Enable sampling at negative edge of touch probe 1

6-7	-	Not Supported	Not used
8	0	Switch off touch probe 2	Touch Probe 2 execute/stop
	1	Enable touch probe 2	
9	0	Trigger first event	Touch Probe 2 event mode selection
	1	Continuous	
10	0	Trigger with touch probe 2 input	Touch Probe 2 Trigger selection (external input/Z phase)
	1	Trigger with zero impulse signal of position encoder	
11	-	Reserved	Not used
12	0	Switch off sampling at positive edge of touch probe 2	Touch Probe 2 Rising edge selection
	1	Enable sampling at positive edge of touch probe 2	
13	0	Switch off sampling at negative edge of touch probe 2	Touch Probe 2 Falling edge selection
	1	Enable sampling at negative edge of touch probe 2	
14-15	-	Not Supported	Not used

Note:

under the same probe, do not set the rising edge and the falling edge at the same time.

4) Touch probe status (60B9h)

Index	Sub-index	Name	Units	Range	Data type	Access	PDO	OP-mode
60B9h	00h	Touch probe status	-	0~65535	U16	ro	TxPDO	ALL
		Touch probe function status.						

Related bit information

Bit	Value	Note
0	0	Touch probe 1 is switch off
	1	Touch probe 1 is enabled
1	0	Touch probe 1 no positive edge value stored
	1	Touch probe 1 positive edge value stored
2	0	Touch probe 1 no negative edge value stored
	1	Touch probe 1 negative edge value stored
3-5	-	Reserved
6-7	-	Not Supported
8	0	Touch probe 2 is switch off
	1	Touch probe 2 is enabled
9	0	Touch probe 2 no positive edge value stored
	1	Touch probe 2 positive edge value stored
10	0	Touch probe 2 no negative edge value stored
	1	Touch probe 2 negative edge value stored
11-13	-	Reserved
14-15	-	Not Supported

5) Obtained clamping position (0x60BA~0x60BD)

Index	Sub-index	Name	Units	Range	Data type	Access	PDO	OP-mode
60BAh	00h	Touch probe pos1 pos value	Command unit	-2147483648~ 2147483647	I32	ro	TxPDO	ALL
		Touch probe1 rising edge clamp position.						
60BBh	00h	Touch probe pos1 neg value	Command unit	-2147483648~ 2147483647	I32	ro	TxPDO	ALL
		Touch probe1 falling edge clamp position.						
60BCh	00h	Touch probe pos2 pos value	Command unit	-2147483648~ 2147483647	I32	ro	TxPDO	ALL

		Touch probe2 rising edge clamp position.						
60BDh	00h	Touch probe pos2 neg value	Command unit	-2147483648~2147483647	I32	ro	TxPDO	ALL
		Touch probe2 falling edge clamp position.						

6) Startup of Touch probe action

When bit0 / bit8 of 60B8h (touch probe function) is from "0 (stop) → 1 (start)", obtain various setting conditions (60B8h: bit1 ~ 7 / bit9 ~ 15), and start Touch probe action.

To make the changes of various setting conditions valid, bit0 / bit8 return "0 (stop)" and then to "1 (start)" again.

To switch the control mode and then use the probe function, also bit0 / bit8 return "0 (stop)" and then to "1 (start)" again.

7) Touch probe event mode

According to 60B8h (Touch probe function) bit1/bit9 (event mode selection), "0(Trigger first event mode)" and "1(Continuous mode)" can be selected.

(1) < Trigger first event mode > (60B8h:bit1=0 / bit9=0)

After starting, this mode only clamps position for the first trigger signal. In order to get it again, it is necessary to start touch probe again.

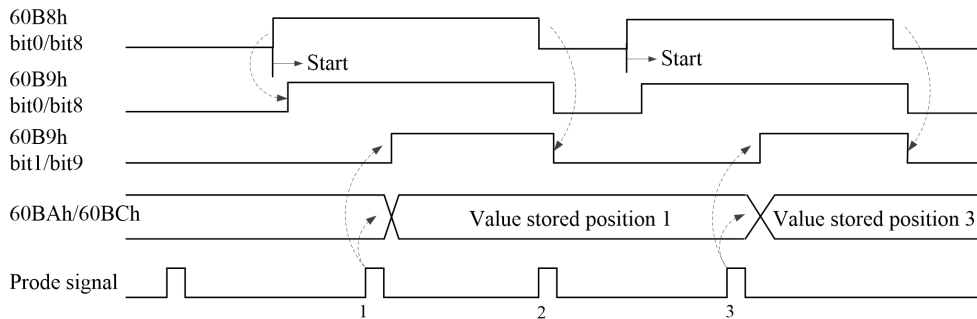

Positive edge

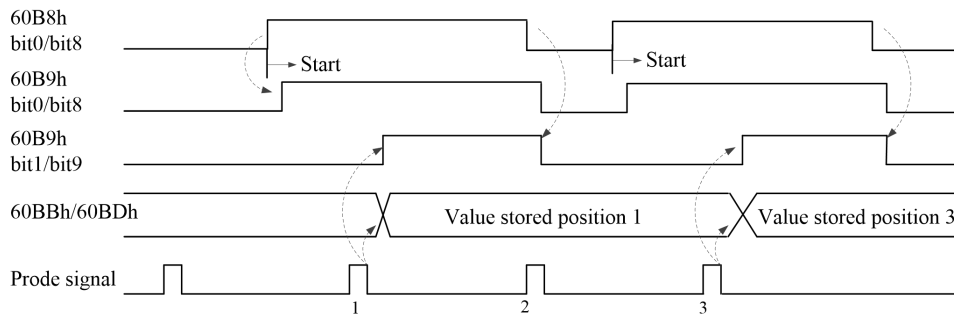

Negative edge

(2) < Continuous mode > (60B8h:bit1=1 / bit9=1)

After startup, this mode clamps position for every trigger signal. The obtained value will be kept for the next Probe signal.

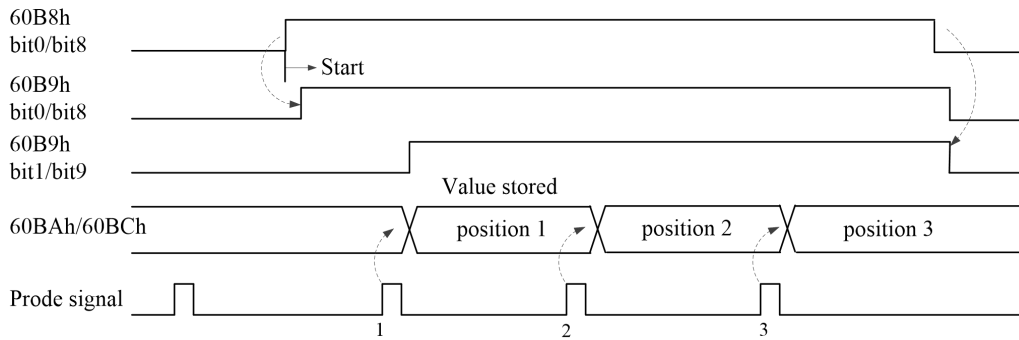

Positive edge

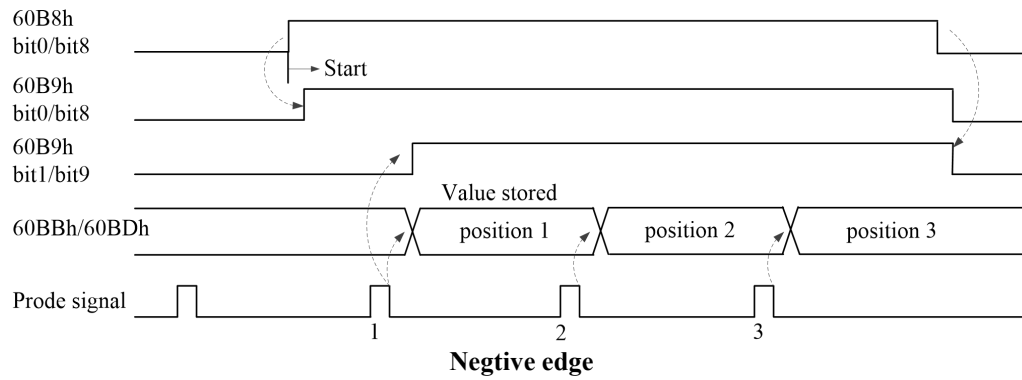

7.9.4 Digital input(60FDh)

The bits of digital input 60FDh are represent the input status of positive limit switch (POT), negative limit switch (NOT), home switch (HOME), Touch probe 1 (Probe 1), and Touch probe 2 (Probe 2) through the functional signals assigned to the DS5C1 series servo parameters P5-22 (POT setting address), P5-23 (NOT setting address), P5-27 (HOME origin setting address), P5-62 (Probe 1 setting address), and P5-63 (Probe 2 setting address).

Digital inputs (60FDh) (version before 3791)

Index	Sub-index	Name/description	Range	Data type	Access	PDO	Op-mode
60FDh	00h	Digital inputs	0~4294967295	U32	ro	TxPDO	All
Represents the theoretical input state to an external input signal.							
Bit information							
31	30	29	28	27	26	25	24
r							
23	22	21	20	19	18	17	16
r							
15	14	13	12	11	10	9	8
r							
7	6	5	4	3	2	1	0
r			tp2	tp1	hs	pls	nls
r = reserved(not corresponding)				pls= positive limit switch			
nls = negative limit switch				hs=home switch			
tp1=Touch probe 1				tp2=Touch probe 2			

Bits details:

Value	Description
0	Input status OFF
1	Input status ON

The values of bit0 (reverse overtravel switch), bit1 (forward overtravel switch), bit2 (origin switch), bit3 (probe 1), and bit4 (probe 2) for 60FD (digital input) represent the signal states of negative driving limit input, positive driving limit input, near origin input, probe 1 input, and probe 2 input, respectively.

Digital inputs (60FDh) (version 3791 and higher)

Index	Sub-index	Name/description	Range	Data type	Access	PDO	Op-mode																																																																
60FDh	00h	Digital inputs	0~4294967295	U32	ro	TxPDO	All																																																																
Represents the theoretical input state to an external input signal.																																																																							
Bit information																																																																							
<table border="1"> <tr> <td>31</td> <td>30</td> <td>29</td> <td>28</td> <td>27</td> <td>26</td> <td>25</td> <td>24</td> </tr> <tr> <td colspan="8" style="text-align: center;">r</td> </tr> <tr> <td>23</td> <td>22</td> <td>21</td> <td>20</td> <td>19</td> <td>18</td> <td>17</td> <td>16</td> </tr> <tr> <td colspan="5" style="text-align: center;">r</td> <td>ri3</td> <td>ri2</td> <td>ri1</td> </tr> <tr> <td>15</td> <td>14</td> <td>13</td> <td>12</td> <td>11</td> <td>10</td> <td>9</td> <td>8</td> </tr> <tr> <td colspan="8" style="text-align: center;">r</td> </tr> <tr> <td>7</td> <td>6</td> <td>5</td> <td>4</td> <td>3</td> <td>2</td> <td>1</td> <td>0</td> </tr> <tr> <td colspan="2" style="text-align: center;">r</td> <td>zos</td> <td>tp2</td> <td>tp1</td> <td>hs</td> <td>pls</td> <td>nls</td> </tr> </table>								31	30	29	28	27	26	25	24	r								23	22	21	20	19	18	17	16	r					ri3	ri2	ri1	15	14	13	12	11	10	9	8	r								7	6	5	4	3	2	1	0	r		zos	tp2	tp1	hs	pls	nls
31	30	29	28	27	26	25	24																																																																
r																																																																							
23	22	21	20	19	18	17	16																																																																
r					ri3	ri2	ri1																																																																
15	14	13	12	11	10	9	8																																																																
r																																																																							
7	6	5	4	3	2	1	0																																																																
r		zos	tp2	tp1	hs	pls	nls																																																																
r = reserved(not corresponding)				pls= positive limit switch																																																																			
nls = negative limit switch				hs=home switch																																																																			
tp1=Touch probe 1				tp2=Touch probe 2																																																																			
zos= zero impulse signal output																																																																							
ri1=remote input1				ri3=remote input3																																																																			
ri2=remote input2																																																																							

Bits details:

Value	Description
0	Input status OFF
1	Input status ON

The values of bit0 (reverse overtravel switch), bit1 (forward overtravel switch), bit2 (origin switch), bit3 (probe 1), bit4 (probe 2), bit5 (Z-phase output), bit16 (remote SI input 1), bit17 (remote SI input 2), and bit18 (remote SI input 3) for 60FD (digital input) represent the signal states of positive driving limit input, negative driving limit input, near origin input, probe 1 input, probe 2 input, Z-phase output, remote SI input 1, remote SI input 2, and remote SI input 3, respectively.

The Z-phase output holding time is modified by the driver parameters:

Parameter	Meaning	Default value	Unit	Range	Modify	Effective
P5-19	Z-phase output holding time	2	ms	1~65535	Anytime	At once

The Z-phase output is affected by the EtherCAT communication cycle and its own software processing, resulting in poor consistency.

7.9.5 Digital output (60FEh)

The bit0 in sub object word 1 of digital output 60FEh represents the zero crossing Z-phase output status bit, and the bit0 in sub object word 2 represents the zero crossing Z-phase output enable bit. Set the Z-phase output enable bit to 1. When the encoder crosses zero, the Z-phase output status bit changes from 0 to 1. After the holding time set in P5-19, the Z-phase output status bit changes from 1 to 0. If the Z-phase output enable bit is set to 0, there is no Z-phase output state, and the value of the Z-phase output state bit is 0.

Digital output (60FEh) (version before 3791)

Index	Sub index	Name	Range	Data type	Accessibility	PDO	Op-mode		
60FEh	00h	Number of entries	2	U8	ro	NO	All		
		The number of Sub Index for 60FEh.							
	01h	Physical outputs	0~4294967295	U32	rw	RxPDO	All		
		Indicates the output status of the external output signal for operation. Bit information							
		31	30	29	28	27	26	25	24
		r							
		23	22	21	20	19	18	17	16
		r							
		15	14	13	12	11	10	9	8
	r								
7	6	5	4	3	2	1	0		
r							zos		
r = reserved (Not corresponding) zos= zero impulse signal output state (Z-phase output status)									
02h	Bit mask	0~4294967295	U32	rw	RxPDO	All			
	Indicates the output operation host function for setting external output signals. Bit information								
	31	30	29	28	27	26	25	24	
	r								
	23	22	21	20	19	18	17	16	
	r								
	15	14	13	12	11	10	9	8	
r									
7	6	5	4	3	2	1	0		
r							zoe		
r = reserved (Not corresponding) zoe= zero impulse signal output enable (Z-phase output enable)									

The details of each bit are as follows:

Subindex 01h: Physical outputs

bit	Name	Value	Description
0	Z-phase output status bit	0	Z-phase output status OFF
		1	Z-phase output status ON

Subindex 02h: Bit mask

bit	Name	Value	Description
0	Z-phase output enable bit	0	Z-phase output enable OFF
		1	Z-phase output enable ON

The bit0 in Subindex 01h (sub object word 1) of digital output 60FEh represents the zero crossing Z-phase output status bit, and the bit0 in Subindex 02h (sub object word 2) represents the zero crossing Z-phase output enable bit. (Cancellation of this function after firmware version 3791).

Digital output (60FEh) (version after 3791)

Index	Sub index	Name	Range	Data type	Accessibility	PDO	Op-mode			
60FEh	00h	Number of entries	2	U8	ro	NO	All			
		The number of Sub Index for 60FEh.								
	01h	Physical outputs	0~4294967295	U32	rw	RxPDO	All			
		Indicates the output status of the external output signal for operation.								
		Bit information								
		31	30	29	28	27	26	25	24	
		r								
		23	22	21	20	19	18	17	16	
		r						ros3	ros2	ros1
		15	14	13	12	11	10	9	8	
r										
7	6	5	4	3	2	1	0			
r										
r = reserved (Not corresponding) ros1= remote output state1 (remote SO output status 1) ros2= remote output state2 (remote SO output status 2) ros3= remote output state3 (remote SO output status 3)										
02h	Bit mask	0~4294967295	U32	rw	RxPDO	All				
	Indicates the output operation host function for setting external output signals.									
	Bit information									
	31	30	29	28	27	26	25	24		
	r									
	23	22	21	20	19	18	17	16		
	r						roe3	roe2	roe1	
	15	14	13	12	11	10	9	8		
r										
7	6	5	4	3	2	1	0			
r										
r = reserved (Not corresponding) roe1= remote output enable1 (remote SO1 output enable 1) roe2= remote output enable2 (remote SO1 output enable 2) roe3= remote output enable3 (remote SO1 output enable 3)										

The details of each bit are as follows:

Subindex 01h: Physical outputs

bit	Name	Value	Description
16	Remote SO1 output status bit	0	Remote SO1 status OFF
		1	Remote SO1 status ON
17	Remote SO2 output status bit	0	Remote SO2 status OFF
		1	Remote SO2 status ON
18	Remote SO3 output status bit	0	Remote SO3 status OFF
		1	Remote SO3 status ON

Subindex 02h: Bit mask

bit	Name	Value	Description
16	Remote SO1 output enable bit	0	Remote SO1 output enable OFF
		1	Remote SO1 output enable ON
17	Remote SO2 output enable bit	0	Remote SO2 output enable OFF
		1	Remote SO2 output enable ON
18	Remote SO3 output enable bit	0	Remote SO3 output enable OFF
		1	Remote SO3 output enable ON

The bits 16, 17, and 18 in Subindex 01h (sub object word 1) of digital output 60FEh represent the remote SO1 output status bit, remote SO2 output status bit, and remote SO3 output status bit, respectively. The bits 16, 17, and 18 in Subindex 02h (sub object word 2) represent the remote SO1 output enable bit, remote SO2 output enable bit,

and remote SO3 output enable bit.

7.9.6 Position information

1) Initialization time of location information

The servo driver initializes (presets) the position information related objects in the following time sequence.

- ◆ Initialization sequence (condition):
 - When the power is put into operation
 - When communication is established (ESM status Init → OP migration)
 - When the original point is reset
 - Absolute multi-turn zero clearing
- ◆ Initialization objects
 - 6062h(Position demand value)
 - 6063h(Position actual internal value)
 - 6064h(Position actual value)
 - 60FCh(Position demand internal value)

The object here is based on the Position actual internal value (6063h) that represents the feedback position of the motor, the electronic gear function described later will add Home offset, etc. according to the polarity change symbol, and initialize (preset) when the communication is established.

In addition, the changes of the set values of electronic gear ratio, Polarity and Home offset are reflected by the time sequence described later in this chapter.

Note: please refer to "initialization of absolute encoder" in Section 4 of this chapter for details of precautions for using absolute encoder.

2) Electronic gear ratio

(1) Function overview

The electronic gear is a function of multiplying the position command input from the upper computer by the electronic gear ratio set by the object as the position command of the position control unit. According to the use of this function, the motor rotation and movement amount of each command unit can be set arbitrarily.

(2) DS5C1 series electronic gear ratio setting method

Method 1: set the electronic gear ratio according to the internal parameters of the servo;

① Determine the number of command pulses required for the motor to rotate for one revolution to ensure that the motor speed can reach the required speed.

Taking the 17 bit encoder motor as an example, The pulse frequency sent by the upper computer PLC is 200kHz:

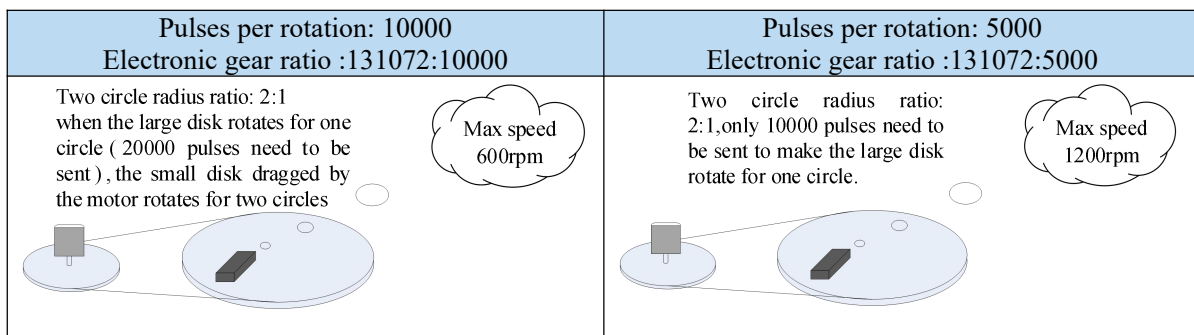

② Set the physical unit length corresponding to 1 command pulse for precise positioning.

As shown in the following figure, if the specified unit pulse corresponds to the workpiece movement of 1um, the load shaft needs 6mm / 1um = 6000 command pulses for one rotation. In the case of deceleration ratio is 1:1, set pulse per rotation P0-11=6000, P0-12=0. Then if the PLC outputs 6000 pulses, the object will move 6mm. (refer to steps 1 to 6 for the specific calculation method).

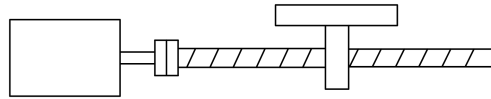

Encoder:131072(17-bit) ball screw pitch: 6mm

Not change the electronic gear ratio	Change the electronic gear ratio
Without changing the electronic gear ratio, the rotating cycle is 131072 pulses (P0-11=0, P0-12=0). When the motor rotates for one turn and the workpiece moves for 6mm, the number of pulses needed is 131072. If the workpiece moves for 10mm, $10 / 6 * 131072 = 218453.333$ pulses are required. When the pulse is actually sent, the decimal will be rounded off, which will cause error.	By changing the electronic gear ratio, 6000 pulses are required for one revolution of the motor. When the motor rotates for one turn and the workpiece moves for 6mm, the number of pulses required is 6000. When the workpiece moves for 10mm, $10 / 6 * 6000 = 10000$ pulses are required. When the pulse is actually sent, there will be no decimals and no error.

■ Related parameters

Parameter	Meaning	Default setting	Unit	Setting range	Change	Effective
P0-11	Pulse numbers per rotation *1	0	pul	0~9999	Servo OFF	At once
P0-12	Pulse numbers per rotation *10000	1	pul	0~9999	Servo OFF	At once
P0-13	Electronic gear ratio (numerator)	1	-	0~65535	Servo OFF	At once
P0-14	Electronic gear ratio (denominator)	1	-	0~65535	Servo OFF	At once
P0-92	Group 2 Electronic gear ratio (numerator) low bit*1	1	-	1~9999	Servo OFF	At once
P0-93	Group 2 Electronic gear ratio (numerator) high bit*10000	0	-	1~65535	Servo OFF	At once
P0-94	Group 2 Electronic gear ratio (denominator) low bit*1	1	-	1~9999	Servo OFF	At once
P0-95	Group 2 Electronic gear ratio (denominator) high bit*10000	0	-	1~65535	Servo OFF	At once

Note:

① P0-11~P0-14 is all about the parameters of electronic gear ratio, P0-11, P0-12 is group 1, P0-13, P0-14 is group 2, but the priority of P0-11 and P0-12 is higher than that of P0-13 and P0-14. Only when P0-11 and P0-12 are set to 0, the ratio of electronic gear P0-13 and P0-14 will take effect.

② When P0-11, P0-12, P0-13 and P0-14 are all set to 0, P0-92, P0-93, P0-94 and P0-95 will take effect.

Calculation of pulse number per rotation and electronic gear ratio

Steps	Contents	Description
1	Confirm the machine specification	Confirm the deceleration ratio n:m (servo motor turns m rotations while load turns n rotations), ball screw distance, pulley diameter.
2	Confirm the encoder pulse	Confirm the servo motor encoder accuracy
3	Set the command unit	Determine the actual distance or angle corresponding to 1 pulse of the controller
4	Calculate the command pulses the load shaft rotates 1 circle	Based on the determined command unit, calculate the command quantity n of the load shaft rotating for 1 revolution.
5	Calculate the pulses per rotation M	Command pulse number of motor shaft rotating for 1 turn $M=N/(m/n)$.
6	Set the pulses per rotation (P0-11/P0-12) or Electronic gear ratio (P0-13/P0-14)/(P0-92~95)	$P0-11=M\%10000$ $P0-12=M/10000$ $P0-13 = \frac{\text{encoder resolution}}{M} = \frac{\text{encoder resolution} \times m}{N \times n}$ $P0-14 = \frac{\text{encoder resolution}}{N \times n}$

priority
 ↓ high
 ↓ low

Note:

(1) In step 6, the effective priority of the number of pulses per revolution is higher than the electronic gear ratio, that is, when P0-11 ~ P0-12 are all 0, P0-13 ~ P0-14 will take effect. In special cases, if the number of pulses per revolution is calculated as a decimal, the electronic gear ratio should be considered.

(2) When P0-13 and P0-14 exceed the setting range, please divide the electronic gear ratio into numerator and denominator. If the ratio still exceeds the parameter setting range, please use the second gear ratio P0-92~P0-95. Only when P0-11~14 = 0, the second gear ratio takes effect.

(3) The resolution of DS5 series servo motor encoder is 131072 (17 bits) and 8388608 (23 bits).

(4) The command unit does not represent the machining accuracy. On the basis of the mechanical accuracy, refining the instruction unit quantity can improve the positioning accuracy of the servo system. For example, when using the lead screw, the mechanical accuracy can reach 0.01mm, so the unit equivalent of 0.01mm is more accurate than the unit equivalent of 0.1mm.

Example of setting the electronic gear ratio

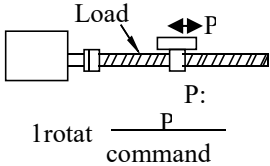
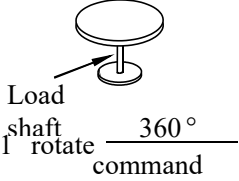
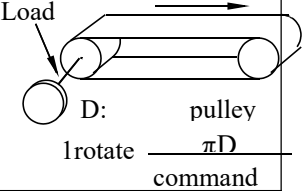
Steps	Name	Ball screw	Round table	Belt + pulley
				
1	Confirm mechanical specifications	Ball screw pitch: 6mm Machine deceleration ratio: 1:1	1-circle rotate angle: 360° Deceleration ratio: 1:3	Pulley diameter: 100mm Deceleration ratio: 1:2
2	Confirm the number of encoder pulses	Encoder resolution 131072	Encoder resolution 131072	Encoder resolution 131072
3	Confirm the command unit	1 command unit: 0.001mm	1 command unit: 0.1°	1 command unit: 0.02mm
4	Calculate the command amount of 1 revolution of load shaft	6mm/0.001mm=6000	360/0.1=3600	314mm/0.02mm=15700
5	Calculate the pulse number m of one revolution of motor shaft	M=6000/(1/1)=6000	M=3600/(3/1)=1200	M=15700/(2/1)=7850
6	Set pulses per rotation P0-11/P0-12	P0-11=6000 P0-12=0	P0-11=1200 P0-12=0	P0-11=7850 P0-12=0
	Set electronic gear ratio(P0-13/P0-14)/(P0-92~95)	P0-13=131072 P0-14=6000 After reduction P0-13=8192 P0-14=375	P0-13=131072 P0-14=1200 After reduction P0-13=8192 P0-14=75	P0-13=131072 P0-14=7850 After reduction P0-13=65536 P0-14=3925 Convert to second gear ratio P0-92=5536 P0-93=6 P0-94=3925 P0-95=0

Method 2:

DS5C1 series servo driver can set electronic gear ratio through the object 608Fh (Position encoder resolution), 6091h (Gear ratio), 6092h (Feed constant) specified by CoE (CiA402).

The following is mainly about setting the electronic gear ratio according to COE (CiA402).

The relationship between user-defined units (instruction units) and internal units (pulse) is calculated according to the following equation.

Calculation formula of electronic gear ratio:

$$\text{Electronic gear ratio} = \frac{\text{Position encoder resolution} \times \text{Gear ratio}}{\text{Feed constant}}$$

$$\text{Position encoder resolution} = \frac{608F: 01(\text{encoder increments})}{608F: 02(\text{motor revolutions})}$$

$$\text{Gear ratio} = \frac{6091: 01(\text{Motor revolutions})}{6091: 02(\text{Shaft revolutions})}$$

$$\text{Feed constant} = \frac{6092: 01(\text{Feed})}{6092: 02(\text{Shaft revolutions})}$$

$$\text{Position demand value}(6062h) \times \text{electronic gear ratio} = \text{Position demand internal value}(60FCh)$$

Note:

(1) The ratio of electronic gear is valid in the range of 8000 to 1/1000 times.

If the out of range value is saturated within the range, E-883 (abnormal action abnormal protection) occurs.

(2) 608FH-01h (encoder increments) is automatically set according to the resolution of the encoder. The factory value of 6092h-01h (feed) is set according to the resolution of encoder.

(3) The setting of electronic gear ratio is reflected by the following time sequence.

- When the power is put into operation
- When communication is established (ESM status Init → OP migration)
- When the original point is reset
- Absolute multi-turn zero clearing

(4) Please note that it does not reflect whether the set value of the associated object changes or not.

The position information initialization when Init ⇒ OP in absolute mode, please set the value of absolute encoder position [pulse / unit] / electronic gear ratio within the range of -2^{31} (- 2147483648) ~ $+2^{31}-1$

(2147483647). Actions outside this range are not guaranteed.

Please confirm the action range of absolute encoder position and gear ratio.

(5) Try to use the electronic gear ratio setting in Cia402 protocol.

■ Related parameter

Position encoder resolution(608Fh)

Index	Sub-index	Name	Units	Range	Data type	Access	PDO	OP-mode
608Fh	-	Position encoder resolution	-	-	-	-	-	-
		The resolution of encoder is set automatically.						
	00h	Highest sub-index supported	-	2	U8	ro	NO	ALL
		Represents the Sub-Indexes of 608FH.						
	01h	Encoder increments	Pulse	1~4294967295	U32	ro	NO	ALL
		Indicates the amount of encoder movement. Value is set automatically by the encoder resolution.						
02h	Motor revolutions	r(motor)	1~4294967295	U32	ro	NO	ALL	
	Indicates the number of motor rotations. The value is fixed to 1.							

This object defines the encoder resolution for each revolution of the motor.

Position encoder resolution = Encoder increments(608Fh-01h) / Motor revolutions (608Fh-02h)

This object is automatically set according to the information read out from the motor connected to the servo driver.

Example: connection of 17 bit/r encoder

608Fh-01h(Encoder increments)= 130172
 608Fh-02h(Motor revolutions)= 1
 Position encoder resolution = 131072 / 1 = 131072

Gear ratio (6091h)

Index	Sub-index	Name	Units	Range	Data type	Access	PDO	OP-mode
6091h	-	Gear ratio	-	-	-	-	-	-
		Set gear ratio						
	00h	Highest sub-index supported	-	2	U8	ro	NO	ALL
		Represents the Sub-Indexes of 6091H.						
	01h	Motor revolutions	Pulse	1~4294967295	U32	rw	NO	ALL
		Motor rotation numbers.						
02h	Shaft revolutions	r(motor)	1~4294967295	U32	rw	NO	ALL	
	Shaft rotation numbers.							

This object defines the number of motor revolutions and the number of shaft revolutions after gearbox output.
 Gear ratio = Motor shaft revolutions(6091h-01h)/ Driving shaft revolutions(6091h-02h).

Feed constant(6092h)

Index	Sub-index	Name	Units	Range	Data type	Access	PDO	OP-mode
6092h	-	Feed constant	-	-	-	-	-	-
		Set the feed constant.						
	00h	Highest sub-index supported	-	2	U8	ro	NO	ALL
		Represents the Sub-Indexes of 6091H.						
	01h	Feed	Command unit	1~4294967295	U32	rw	NO	ALL
		Set the feed quantity.						
02h	Shaft revolutions	r (motor)	1~4294967295	U32	rw	NO	ALL	
	Set the shaft rotation number.							

This object represents the action amount of shaft each revolution after the gearbox outputs.
 Feed constant =Feed(6092h-01h)/ Driving shaft revolutions(6092h-02h).

3) Polarity function (607Eh)

For position command, speed command, torque command and its offset, polarity (motor rotation direction) can be set. DS5C1 series performs the setting of rotation direction according to the object Polarity (607EH) specified by CoE (CiA402) and parameter P0-5 (rotation direction setting) which does not correspond to the setting of rotation direction.

In addition, Polarity (607Eh) is not the object that replacement of parameter P0-05 (rotation direction setting). It is valid when the data transmission of the object corresponding to the following table is executed between the CoE (CiA402) processing unit and the motor control processing unit.

Index	Sub-index	Name	Units	Range	Data type	Access	PDO	OP-mode
607Eh	00h	Polarity	-	0~255	U8	rw	NO	ALL
		Set the polarity when the values of position instruction, speed instruction, torque instruction and position offset, speed offset (speed addition) and torque offset (torque addition) are transferred from the object to the internal processing, and the polarity when the values of position feedback, speed feedback and torque feedback are transferred from the internal processing to the object.						
		Note: for the setting value of this object, please set the polarity of position, speed and torque to 0 or 224 (bit 7-5 = 1).						
		Actions under other settings cannot be guaranteed.						
		Setting value		Contents				
0		Symbol of position, speed and torque has no reversal						
224		Symbol of position, speed and torque has reversal						
Others		Cannot support (do not set)						

		<p>bit7: position polarity 0: symbol no reversal 1: symbol has reversal</p> <p>bit6: speed polarity 0: symbol no reversal 1: symbol has reversal</p> <p>bit5:torque polarity 0: symbol no reversal 1: symbol has reversal</p> <p>bit4-0: Reserved, please set to 0</p> <p>object <command · setting> · 607Ah (Target position) · 60B0h (Position offset) · 60FFh (Target velocity) · 60B1h (Velocity offset) · 6071h (Target torque) · 60B2h (Torque offset)</p> <p>object <command · setting> ▪ 607Ah (Target position) ▪ 60B0h (Position offset) ▪ 60FFh (Target velocity) ▪ 60B1h (Velocity offset) ▪ 6071h (Target torque) ▪ 60B2h (Torque offset)</p> <p>object <command · setting> ▪ 607Ah(Target position) ▪ 60B0h(Position offset) ▪ 60FFh(Target velocity) ▪ 60B1h(Velocity offset) ▪ 6071h(Target torque) ▪ 60B2h(Torque offset)</p> <p><monitor> ▪ 6062h(Position demand value) ▪ 6064h(Position actual value) ▪ 606Bh(Velocity demand value) ▪ 606Ch(Velocity actual value) ▪ 6074h(Torque demand) ▪ 6077h(Torque actual value) ▪ 6078h(Current actual value)</p>
--	--	--

Symbol no reversal: for the positive direction command, the motor rotation reverse direction is CCW direction;
Symbol has reversal: for the positive direction command, the motor rotation reverse direction is CW direction.
When the rotation direction of the motor is viewed from the shaft end of the load side, CW is defined as clockwise and CCW is defined as anticlockwise.

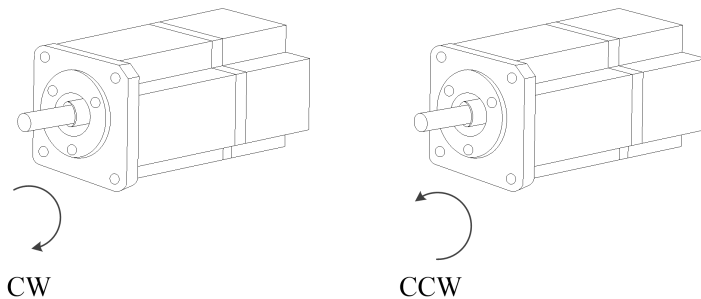

4) Initialization of absolute encoder

If the absolute encoder is used in the position control mode, the zero point reset action is not required (except for the case that the absolute encoder is used as an incremental encoder). After the installation of the battery, it is necessary to clear the data of multiple turns at the initial start-up of the device.

(1) Absolute data

Among the data read out from the absolute encoder, there are the built-in single turn data within one turn of the motor and the multi-turn data which are counted once per revolution. Among them, multi-turn data needs to be backed up by batteries because it is an electrical count. Both data are increased when rotating from the CCW direction of the motor shaft end. E-228 alarm (absolute counter overflow protection) occurs when the multi-turn data overflows.

(2) Absolute data to 32-bit data mapping

This servo driver initializes the position information. If it is a 23-bit encoder, the single turn data is 23-bit, and the multi-turn data is 16-bit. The synthesized position information is 39-bit, but as the position information, the setting value of the object is 32-bit. Because only the lower 32 bits of the absolute encoder data are set as position information in 6063h, the upper 7 bits of 16 bits multi-turn data disappeared, and the effective length of one bit becomes 9 bits. 6064h position information is calculated based on the following formula, and the calculated position information becomes 32-bit. Therefore, the effective bit length of the multi-turn data varies according to the inverse transformation value of the electronic gear.

607Eh (Polarity)	Position information
The condition of 0 (CCW is positive direction)	6063h=M*2 ¹⁷ +S
	6064h= (6063h* inverse transformation value of the electronic gear)+607Ch
The condition of 224 (CW is positive direction)	6063h= - (M*2 ¹⁷ +S)
	6064h=(6063h* inverse transformation value of the electronic gear)-607Ch

M:multi-turn data
S: single turn data

5) Position range limit (607Bh)

The DS5C1 series servo driver does not support wrap-around.

Infinite rotation mode acts as 607Bh-01h=80000000h, 607Bh-02h=7FFFFFFFh in the interior. Modifying this object is not affected either.

6) Homing offset(607Ch)

Set the offset quantity of the mechanical origin offset after returning to the mechanical origin, and use this position as the mechanical zero point. If it is set to 0, the mechanical origin will coincide with the mechanical zero point. The origin offset can be set as a positive or negative number to indicate the left or right deviation from the mechanical origin.

Note: The DS5C1 series driver 3793 and later versions support multi-turn motor power-off memory with homing offset.

This object can be updated at any time, but it needs to reflect the actual location information through the following time sequence.

- When the power is put into operation
- When communication is established (when ESM status is Init → OP migration)
- When the original point is reset

The position under the above time sequence is used as the reference to initialize(preset) the following objects

- When the origin position is detected (only valid in home mode 35 and 37)

$$6063h(\text{Position actual internal value})=60FCh(\text{Position demand internal value})=0$$

$$6062h(\text{Position demand value})=6064h(\text{Position actual value})=607Ch(\text{Home offset})$$

- Initialization (preset) in time sequence other than the origin position is detected

$$6063h(\text{Position actual internal value})=60FCh(\text{Position demand internal value})$$

$$6062h(\text{Position demand value})=6064h(\text{Position actual value})$$

$$=6063h(\text{Position actual internal value})+607Ch(\text{Home offset})$$

Note: the above is the case when the electronic gear ratio is 1:1 and there is no polarity reversal.

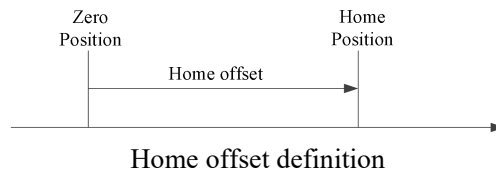

Home position: Index pulse position (origin position)

Zero position: Incremental system = 0 (The position when the power is on, or the position where the home offset is subtracted by the position where the Index pulse is detected in HM)

Absolute system = Zero position of absolute encoder.

7.9.7 Overtravel function in Ethercat mode

1. Version before 3770 (excluding 3770)

In EtherCAT mode before 3770 (P0-00=1), the POT, NOT, and origin signals only take effect in HM homing mode, while in PP, CSP, PV, CSV, TQ, and CST modes, the motor will not stop when encountering POT and NOT signals.

2. Version 3770~3790

In control modes PP, CSP, PV, CSV, TQ, and CST, versions 3770-3790 have different servo processing methods when encountering POT and NOT signals based on the P0-28 setting values.

Parameter	Meaning	Default value	Unit	Range	Modify	Effective
P0-28.0	Version 3770~3790 0, 2: servo does not process 1: enable E-260 overtravel protection function	2	-	0~3	○	1 3 4 8 9 10

① P0-28=1, activate E-260 overtravel protection function

When P0-28 is 1, assuming that the forward operation encounters the rising edge of the POT overtravel signal, the servo will alarm E-260. The alarm needs to be cleared and re enabled before continuing to issue instructions for operation. After the alarm is cleared and re enabled, if it is still within the POT overtravel range and a positive direction command is received, the motor will continue to remain stationary; Received a command in the opposite direction, the motor will operate according to the command and continue to run in the opposite direction.

If it is no longer within the POT overtravel range at this time, the forward/directional command will be executed normally, but please ensure that it does not move towards the POT overtravel direction again. Similarly, when encountering NOT overtravel signals, the servo processing method is the same.

② P0-28 is 2 (or not 1), blocking the E-260 overtravel protection function

P0-28 is 2 (or not 1), the servo does not process the over travel signal and will not alarm E-260. However, the overtravel signal of POT/NOT will be fed back to the main station through the 60FD status bit, and the main station will command to slow down and stop processing. Please contact the manufacturer's technical support for specific usage.

To use this function, 60FD needs to be added to the PDO mapping. Based on the limit state bits of 60FD, the main station needs to configure the axis, limit configuration, and set the servo positive limit IO sequence to 1 and the servo negative limit IO sequence to 0. When encountering a limit master station for command deceleration processing, the master station will report an axis command error code of 2000 or 2001, and the alarm needs to be cleared to run in reverse.

3. Version 3791 and higher

In the control modes PP, CSP, PV, CSV, TQ, and CST of version 3791, according to the P0-28 setting values, when encountering POT and NOT signals, the servo has different processing methods.

Parameter	Meaning	Default value	Unit	Range	Modify	Effective
P0-28.0	3791 and higher versions: 0: Direct alarm, using servo deceleration shutdown method 1: Alarm triggered after deceleration and shutdown in 605Ah mode	2	-	0~3	○	1 3 4 8 9 10

	2: Do not use overtravel					
--	--------------------------	--	--	--	--	--

■ Prohibited status

Scenario 1:

When the servo is in an enabled not motion or disabled state and touches the reverse limit switch, the panel will display NOT, cancel the reverse limit signal, and the panel will return to its previous state.

Scenario 2:

When the servo is in an enabled not motion or disabled state and touches the forward limit switch, the panel will display POT, cancel the forward limit signal, and the panel will return to its previous state.

Scenario 3:

When the servo is in an enabled not motion or disabled state and simultaneously touches the forward and reverse limit switches, the servo will report E-261. If two limit signals are cancelled, the panel will return to its previous state; If any limit signal is cancelled, the panel will display another limit signal, which needs to be cancelled before the panel can return to its previous state.

■ Normal operation status

(1) Initial movement direction to the left

The initial direction of movement is left. When touching the forward limit switch, the servo will report E-261. If the forward limit switch is cancelled first, and then the alarm is cleared, the shaft will return to a non enabled state, and both the forward and reverse directions of the shaft can move; If the alarm is cleared first and the axis returns to the disabled state, but the panel still displays POT, the axis is still in the forward limit restricted state. The forward limit signal needs to be cancelled in order to release the forward overtravel prohibition.

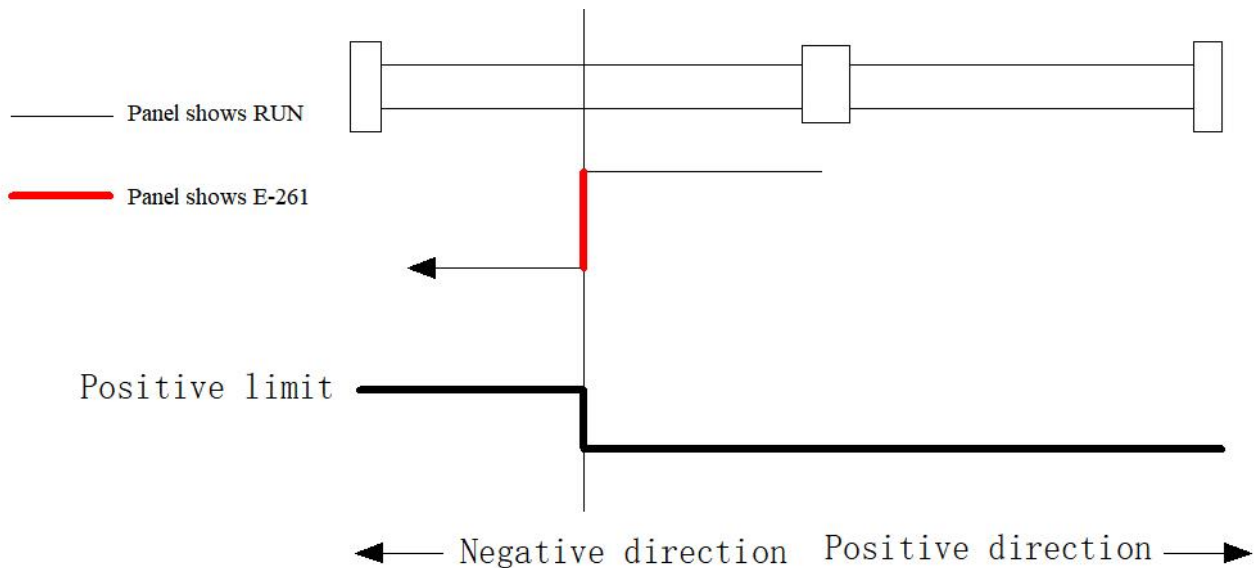

■ Overtravel status

P0-28 set to 1 (Alarm deceleration stop)

(1) Initial movement direction to the left, triggering the overtravel signal without occurrence of offside

Scenario 1: Failure to touch the forward limit switch

The initial direction of movement is left. When touching the rising edge of the reverse limit switch, the panel display changes from RUN to NOT, triggering the reverse overtravel deceleration stop. The shaft stops on the reverse limit switch, and the servo will report E-260. The alarm must be cleared to move the axis in the forward direction. When it touches the falling edge of the reverse limit switch, the panel display can change from NOT to RUN, and the reverse overtravel prohibition can be released.

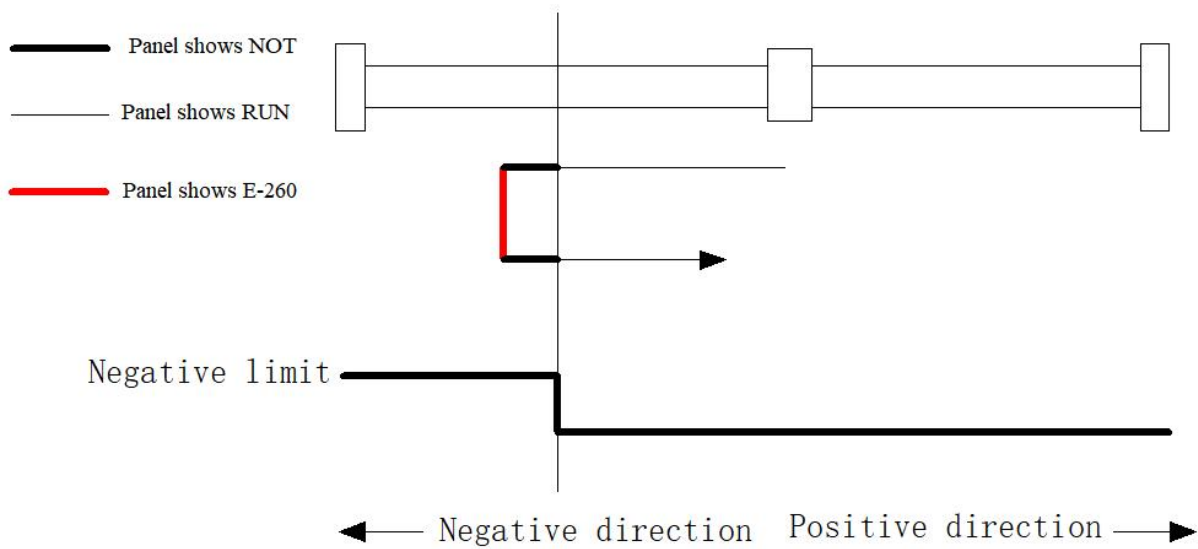

Scenario 2: Before the axis deceleration stops, touch the forward limit switch

The initial direction of movement is left. When touching the rising edge of the reverse limit switch, the panel display changes from RUN to NOT, triggering the reverse overtravel deceleration stop. Before the shaft stops, if the forward limit switch is touched, the servo will report E-261. The forward limit switch must be cancelled in order to clear the E-261 alarm. Otherwise, the alarm cannot be cleared. Then, the shaft moves forward and touches the falling edge of the reverse limit switch. Only then can the panel display change from NOT to RUN, and the reverse overtravel prohibition be released.

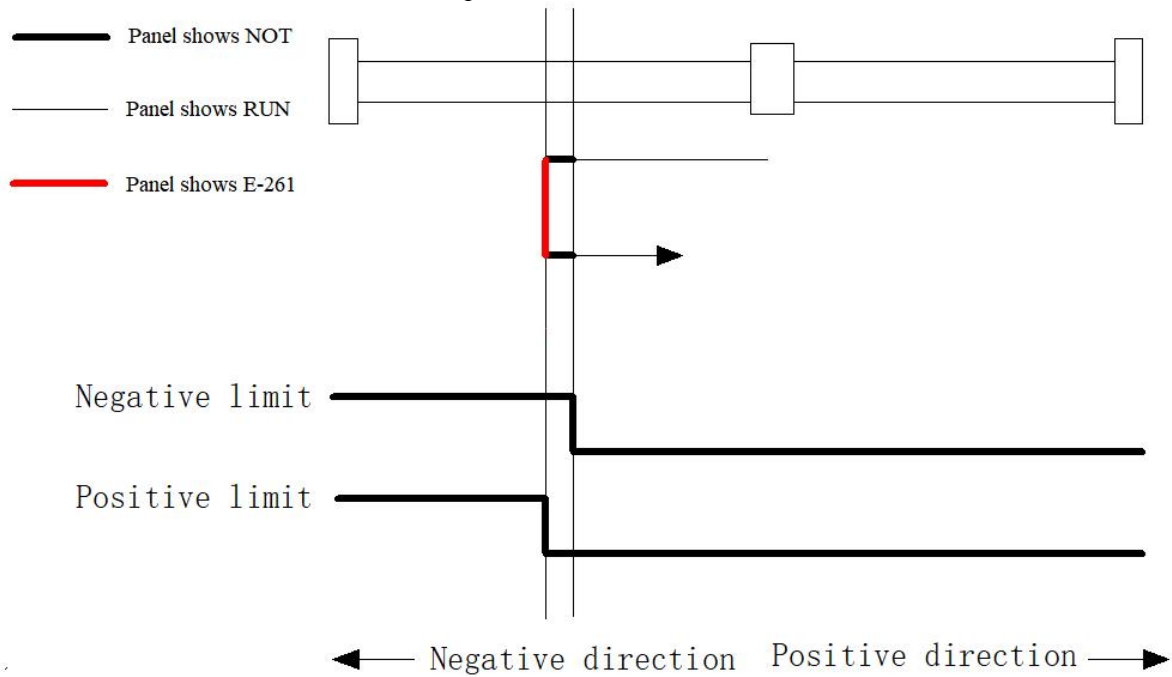

Scenario 3: When the shaft stops at the negative limit switch and touches the positive limit switch
 The initial direction of movement is left. When touching the rising edge of the reverse limit switch, the panel display changes from RUN to NOT, triggering the reverse overtravel deceleration stop. When the shaft stops on the reverse limit switch, the servo will report E-260. At this time, if the forward limit switch is touched, the servo will report E-261. The forward limit switch must be cancelled before the E-261 alarm can be cleared. Otherwise, the alarm cannot be cleared. Then, when the shaft moves forward and touches the falling edge of the reverse limit switch, the panel display can change from NOT to RUN, and the reverse overtravel prohibition can be released.

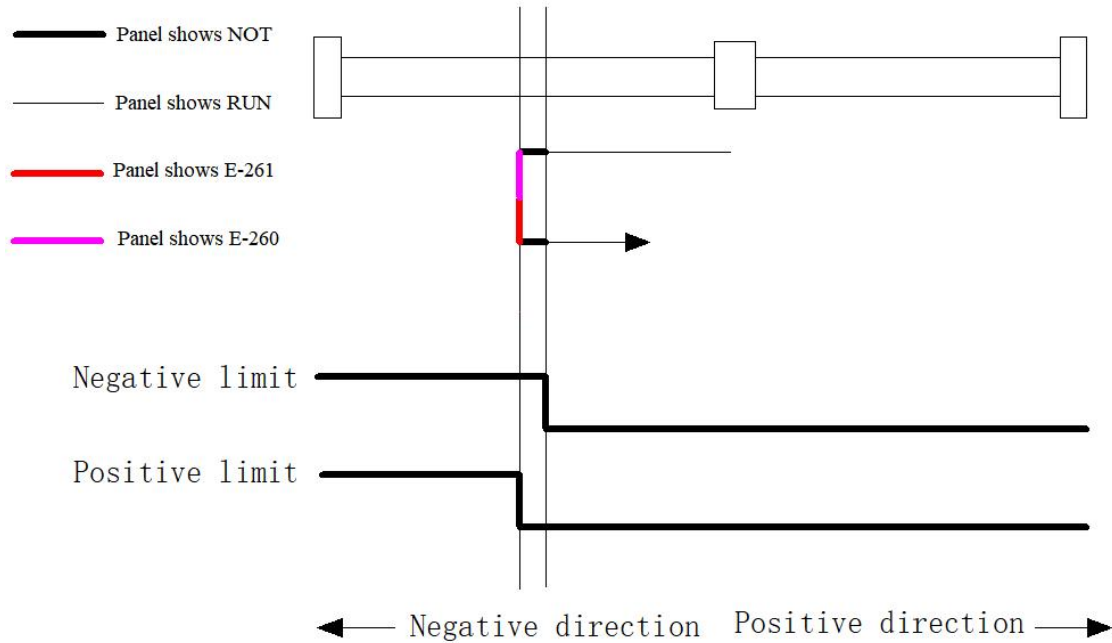

Scenario 4: When touching the forward limit switch during axis forward movement
 The initial direction of movement is left. When touching the rising edge of the reverse limit switch, the panel display changes from RUN to NOT, triggering the reverse overtravel deceleration stop. When the shaft stops on the reverse limit switch, the servo will report E-260. After clearing the alarm to make the shaft move forward, if the forward limit switch is touched, the servo will report E-261. The forward limit switch must be cancelled before the E-261 alarm can be cleared. Otherwise, the alarm cannot be cleared. Continue to move the shaft forward, touch the falling edge of the reverse limit switch, and the panel display can change from NOT to RUN to release the reverse overtravel prohibition.

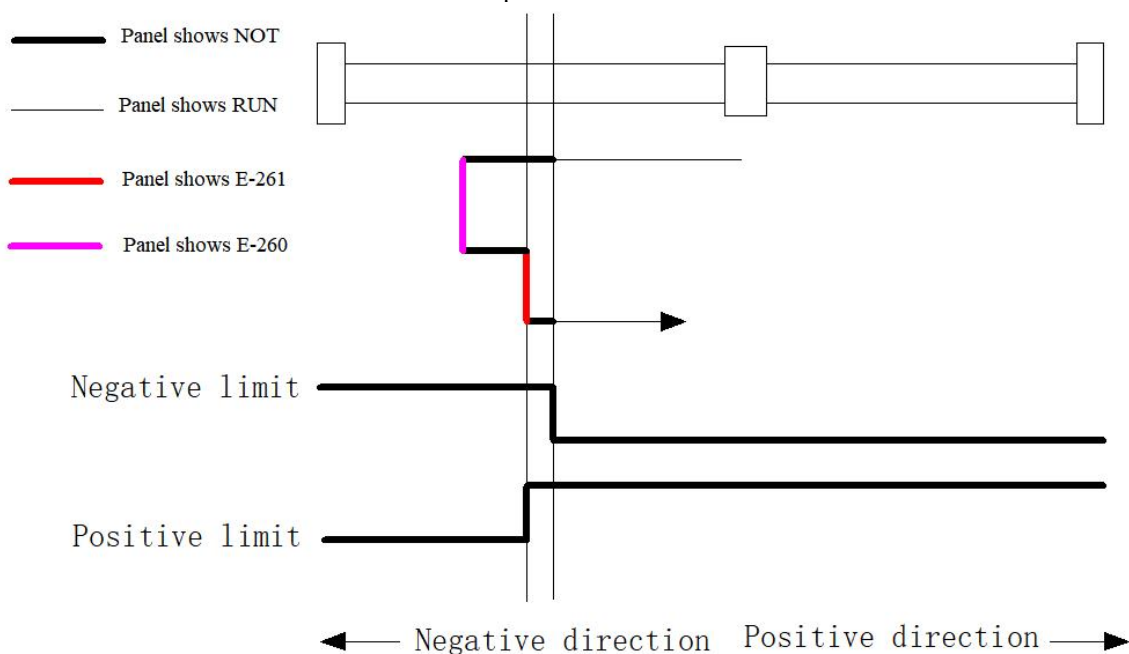

(2) The initial movement direction is to the left, triggering an overtravel signal and out of range occurred
 Scenario 1: Without touching the forward limit switch while offside

The initial direction of movement is to the left. When touching the rising edge of the reverse limit switch, the panel display changes from RUN to NOT, triggering the reverse overtravel deceleration stop. However, the axis crosses the reverse limit switch and triggers the falling edge of the reverse limit switch. The axis stops outside the limit, and the servo will report E-260. The alarm must be cleared to make the axis move forward. Touch the rising and falling edges of the reverse limit switch again before the panel display can change from NOT to RUN, and the reverse overtravel prohibition can be released.

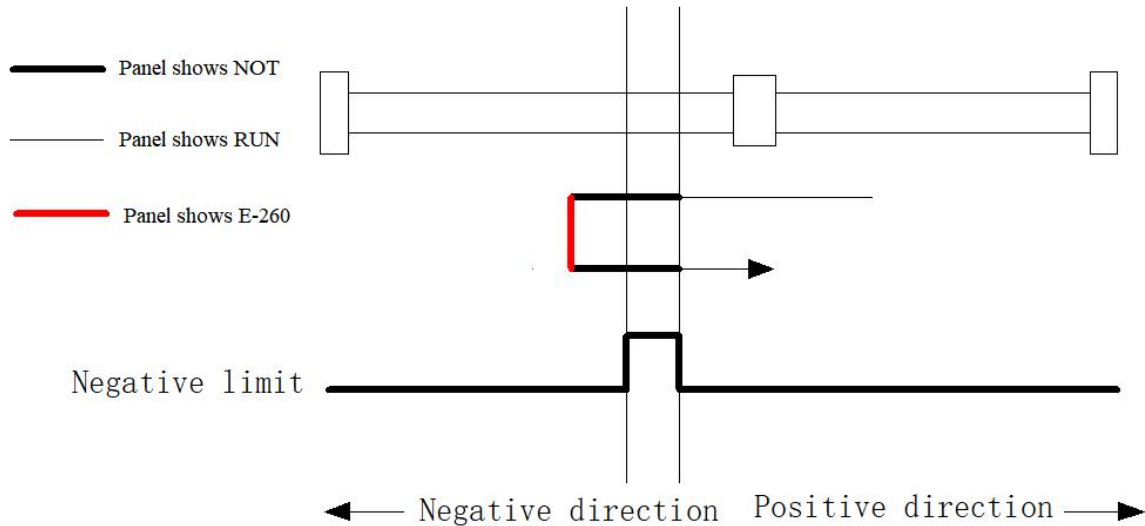

Scenario 2: In the case of offside, touch the forward limit switch before the axis deceleration stop is completed
 The initial direction of movement is left. When touching the rising edge of the reverse limit switch, the panel display changes from RUN to NOT, triggering the reverse overtravel deceleration stop. However, the axis crosses the reverse limit switch and triggers the falling edge of the reverse limit switch. Before the shaft stops, if the forward limit switch is touched, the servo will report E-261. The forward limit switch must be cancelled in order to clear the E-261 alarm. Otherwise, the alarm cannot be cleared. Then, the shaft moves forward and touches the rising and falling edges of the reverse limit switch again. Only then can the panel display change from NOT to RUN, and the reverse overtravel prohibition be released.

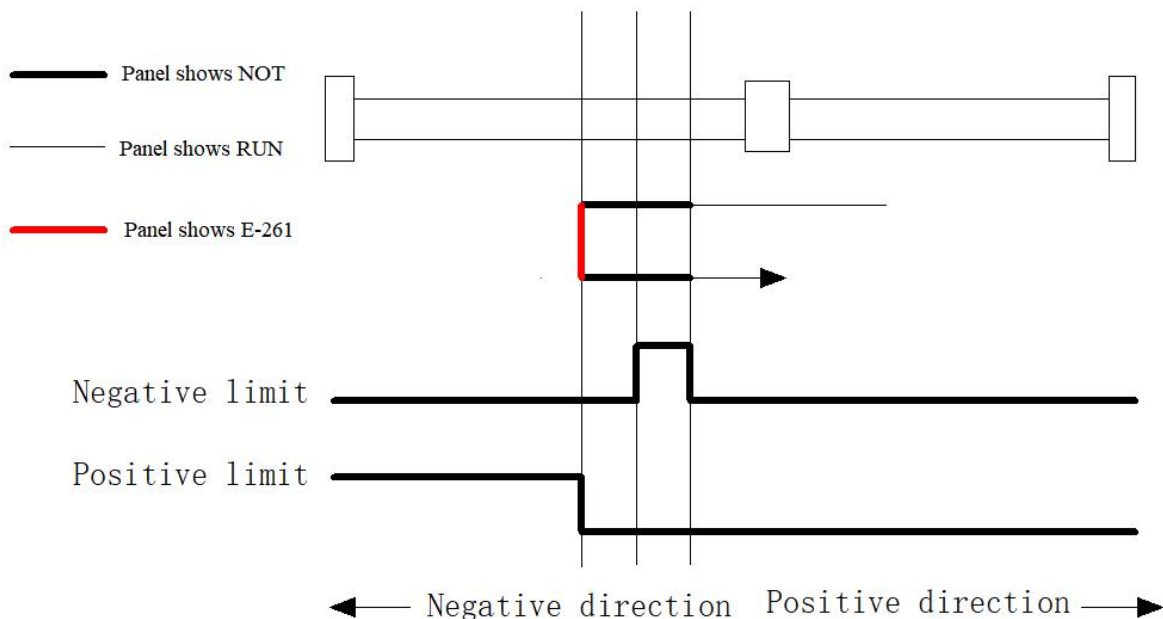

Scenario 3: In the case of offside, when the shaft stops, touch the forward limit switch

The initial direction of movement is left. When touching the rising edge of the reverse limit switch, the panel display changes from RUN to NOT, triggering the reverse overtravel deceleration stop. However, the axis crosses the reverse limit switch and triggers the falling edge of the reverse limit switch. When the shaft stops, the servo will report E-260. At this time, if the forward limit switch is touched, the servo will report E-261. The forward limit switch must be cancelled before the E-261 alarm can be cleared. Otherwise, the alarm cannot be cleared. Then, the shaft will move forward and touch the rising and falling edges of the reverse limit switch again. Only then can the panel display change from NOT to RUN, and the reverse overtravel prohibition be released.

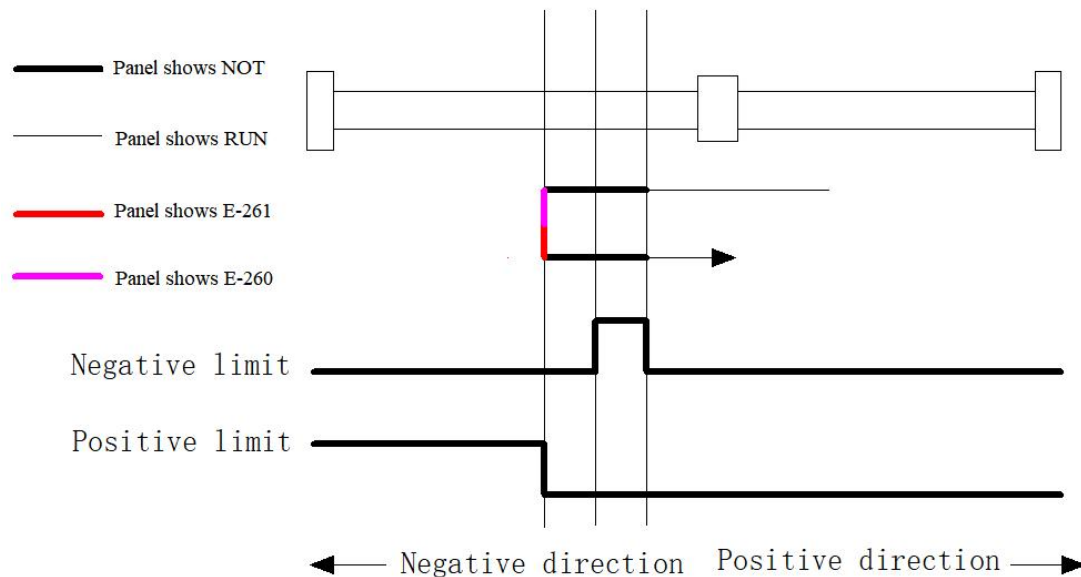

Scenario 4: In the case of offside, touching the forward limit switch during axis forward movement

The initial direction of movement is left. When touching the rising edge of the reverse limit switch, the panel display changes from RUN to NOT, triggering the reverse overtravel deceleration stop. However, the axis crosses the reverse limit switch and triggers the falling edge of the reverse limit switch. When the shaft stops, the servo will report E-260. After clearing the alarm to move the shaft forward, if the forward limit switch is touched, the servo will report E-261. The forward limit switch must be cancelled before the E-261 alarm can be cleared. Otherwise, the alarm cannot be cleared. Continue to move the shaft forward, touch the rising and falling edges of the reverse limit switch again, and the panel display can change from NOT to RUN to release the reverse overtravel prohibition.

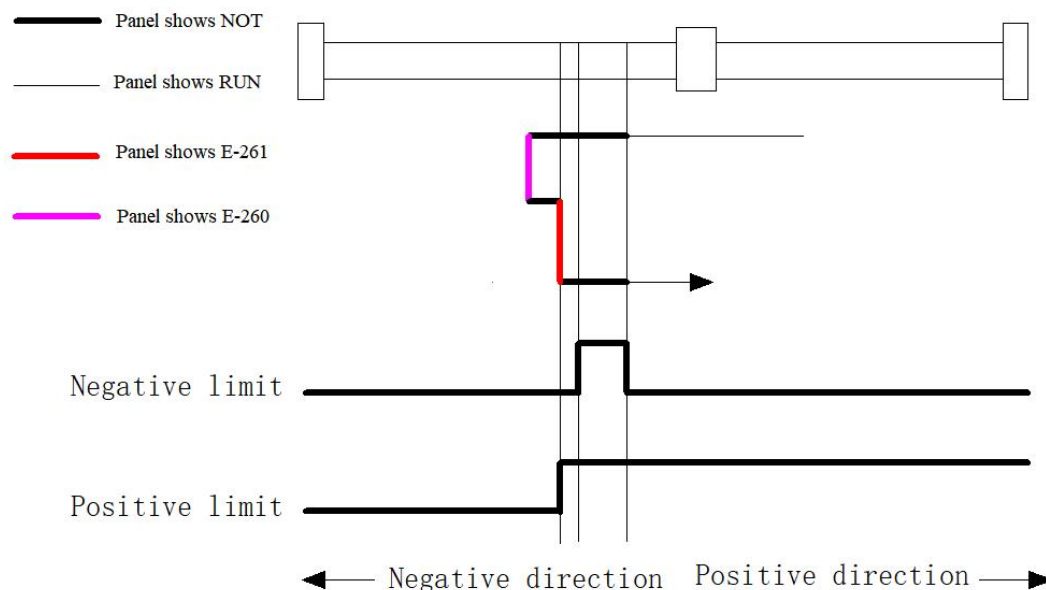

7.9.8 Remote I/O function (version 3791 and higher supported)

■ General related parameters

Parameter	Meaning	Default	Setting
P5-72	Remote SI input 1	0	0: Invalid 1: Input positive signal from SI1 2: Input positive signal from SI2 3: Input positive signal from SI3 16: Always set as valid 17: Input reverse signal from SI1 18: Input reverse signal from SI2 19: Input reverse signal from SI3
P5-73	Remote SI input 2	0	0: Invalid 1: Input positive signal from SI1 2: Input positive signal from SI2 3: Input positive signal from SI3 16: Always set as valid 17: Input reverse signal from SI1 18: Input reverse signal from SI2 19: Input reverse signal from SI3
P5-74	Remote SI input 3	0	0: Invalid 1: Input positive signal from SI1 2: Input positive signal from SI2 3: Input positive signal from SI3 16: Always set as valid 17: Input reverse signal from SI1 18: Input reverse signal from SI2 19: Input reverse signal from SI3
P5-76	Remote output 1	SO	0: Do not output to terminals 1: Output positive signal from SO1 2: Output positive signal from SO2 3: Output positive signal from SO3 17: Output reverse signal from SO1 18: Output reverse signal from SO2 19: Output reverse signal from SO3
P5-77	Remote output 2	SO	0: Do not output to terminals 1: Output positive signal from SO1 2: Output positive signal from SO2 3: Output positive signal from SO3 17: Output reverse signal from SO1 18: Output reverse signal from SO2 19: Output reverse signal from SO3
P5-78	Remote output 3	SO	0: Do not output to terminals 1: Output positive signal from SO1 2: Output positive signal from SO2 3: Output positive signal from SO3 17: Output reverse signal from SO1 18: Output reverse signal from SO2 19: Output reverse signal from SO3

■ Remote I/O related dictionary objects

Object	Meaning	Unit	Explanation
60FDh	Digital inputs	-	Bit0: N-OT signal Bit1: P-OT signal Bit2: SPDD signal Bit3: Probe 1 signal Bit4: Probe 2 signal Bit5: Z-phase signal output Bit6~Bit15 reserved Bit16: Remote SI input 1 Bit17: Remote SI Input 2 Bit18: Remote SI input 3
60FEh:01	Physical outputs	-	Bit0~Bit15 reserved Bit16: Remote SO output 1 Bit17: Remote SO output 2 Bit18: Remote SO output 3
60Feh:02	Bit mask	-	When using, Bit16~Bit18 should correspond to position 1

For specific information on 60FDh, please refer to Chapter 7.9.4 Digital Input (60FDh)

For specific information on 60FEh, please refer to Chapter 7.9.5 Digital Output (60FEh)



Before installing the XINJE-DS5C-ECT-XB.XML file, all servo related XML files in the original PLC installation path need to be deleted. If using the original Xml file, objects P5-72 to P5-78 will not be displayed. (Currently, XML 4.0 is still being used, so P5-72~P5-78 are not included in the coe-line)

7.9.9 Cascade alarm function

3770 and later versions have added an external terminal emergency alarm function. When this function is enabled, if the terminal signal is conductive, the driver will generate an alarm E-320. The driver can be used in cascade, and by connecting the alarm output to this functional terminal of the next driver, a cascade alarm can be triggered.

New function parameter P5-68, default setting of P5-68 to 0:

Parameter	Meaning	Default value	Unit	Range	Modify	Effective
P5-68	Terminal emergency alarm function	0	-	00~ff	Anytime	At once

8 Object dictionary

This chapter mainly introduces the object dictionary area allocation, COE communication area, driver profile area and so on.

8.1 Object dictionary area assignment

All objects are configured in the object dictionary of each group through 4 digits 16-bit index configuration address.

The object dictionary of CoE (CANopen over EtherCAT) specified by CiA402 and the object dictionary of DS5C1 series are as follows:

Object dictionary specified by CiA402		DS5C1 series object dictionary	
Index	Content	Index	Content
0000h~0FFFh	Data type area	0000h~0FFFh	Data type area
1000h~1FFFh	COE communication area	1000h~1FFFh	COE communication area
2000h~5FFFh	Factory custom area	2000h~2FFFh	Servo parameter area
		3000h~3FFFh	
		4000h~4FFFh	
		5000h~5FFFh	
6000h~9FFFh	Profile area	6000h~6FFFh	Driver Profile area
		7000h~9FFFh	Reserved
A000h~FFFFh	Reserved	A000h~FFFFh	Reserved

8.2 COE communication area (0x1000-0x1FFF)

8.2.1 Object list

1) Device information object:

Index	Sub-index	Name
1000h	00h	Device type
1001h	00h	Error register
1008h	00h	Manufacturer device name
1009h	00h	Manufacturer hardware version
100Ah	00h	Manufacturer software version
1018h	-	Identity object
	00h	Number of entries
	01h	Vendor ID
	02h	Product code
	03h	Revision number
	04h	Serial number

2) RxPDO object mapping

Index	Sub-index	Name
1600h	-	Receive PDO mapping 1
	00h	Number of entries
	01h	1st receive PDO mapped
	02h	2nd receive PDO mapped
	03h	3rd receive PDO mapped
	04h	4th receive PDO mapped
	05h	5th receive PDO mapped

	18h	24th receive PDO mapped
	1601h	-
00h		Number of entries
01h		1st receive PDO mapped

Index	Sub-index	Name
	02h	2nd receive PDO mapped
	03h	3rd receive PDO mapped
	04h	4th receive PDO mapped
	05h	5th receive PDO mapped

	18h	24th receive PDO mapped
1602h	-	Receive PDO mapping 3
	00h	Number of entries
	01h	1st receive PDO mapped
	02h	2nd receive PDO mapped
	03h	3rd receive PDO mapped
	04h	4th receive PDO mapped
	05h	5th receive PDO mapped

	18h	24th receive PDO mapped
1603h	-	Receive PDO mapping 4
	00h	Number of entries
	01h	1st receive PDO mapped
	02h	2nd receive PDO mapped
	03h	3rd receive PDO mapped
	04h	4th receive PDO mapped
	05h	5th receive PDO mapped

	18h	24th receive PDO mapped

3) TxPDO object mapping:

Index	Sub-index	Name
1A00h	-	Transmit PDO mapping 1
	00h	Number of entries
	01h	1st transmit PDO mapped
	02h	2nd transmit PDO mapped
	03h	3rd transmit PDO mapped
	04h	4th transmit PDO mapped
	05h	5th transmit PDO mapped

	18h	24th transmit PDO mapped
1A01h	-	Transmit PDO mapping 2
	00h	Number of entries
	01h	1st transmit PDO mapped
	02h	2nd transmit PDO mapped
	03h	3rd transmit PDO mapped
	04h	4th transmit PDO mapped
	05h	5th transmit PDO mapped

	18h	24th transmit PDO mapped
1A02h	-	Transmit PDO mapping 3
	00h	Number of entries
	01h	1st transmit PDO mapped
	02h	2nd transmit PDO mapped
	03h	3rd transmit PDO mapped
	04h	4th transmit PDO mapped
	05h	5th transmit PDO mapped

	18h	24th transmit PDO mapped
1A03h	-	Transmit PDO mapping 4
	00h	Number of entries
	01h	1st transmit PDO mapped

Index	Sub-index	Name
	02h	2nd transmit PDO mapped
	03h	3rd transmit PDO mapped
	04h	4th transmit PDO mapped
	05h	5th transmit PDO mapped

	18h	24th transmit PDO mapped

4) PDO object distribution:

Index	Sub-Index	Name
1C12h	-	Sync manager channel 2
	00h	Number of assigned PDOs
	01h	Assigned RxPDO 1
	02h	Assigned RxPDO 2
	03h	Assigned RxPDO 3
	04h	Assigned RxPDO 4
Index	Sub-Index	Name
1C13h	-	Sync manager channel 3
	00h	Number of assigned PDOs
	01h	Assigned TxPDO 1
	02h	Assigned TxPDO 2
	03h	Assigned TxPDO 3
	04h	Assigned TxPDO 4

5) PDO synchronous management channel

Index	Sub-Index	Name
1C32h	-	Sync manager 2 synchronization
	00h	Number of sub-objects
	01h	Sync mode
	02h	Cycle time
	03h	Shift time
	04h	Sync modes supported
	05h	Minimum cycle time
	06h	Calc and copy time
	08h	Command (not support)
	09h	Delay time (not support)
	0Ah	Sync0 cycle time
	0Bh	Cycle time too small (not support)
	0Ch	SM-event missed (not support)
	0Dh	Shift time too short (not support)
	0Eh	RxPDO toggle failed (not support)
	20h	Sync error
1C33h	-	Sync manager 3 synchronization
	00h	Number of sub-objects
	01h	Sync mode
	02h	Cycle time
	03h	Shift time
	04h	Sync modes supported
	05h	Minimum cycle time
	06h	Calc and copy time
	08h	Command (not support)
	09h	Delay time (not support)
	0Ah	Sync0 cycle time
	0Bh	Cycle time too small (not support)
	0Ch	SM-event missed (not support)
	0Dh	Shift time too short (not support)
	0Eh	RxPDO toggle failed (not support)
	20h	Sync error

8.2.2 Device information

This section describes the equipment information.

Index	Sub-index	Name/Description	Range	DateType	Access	PDO	Op-mode																
1000h	00h	Divece type	0~4294967295	U32	ro	NO	All																
		Indicates the device type. In case of servo driver, the value is fixed to 04020192h.																					
1001h	00h	error register	0~65535	U16	ro	TxPDO	All																
		Displays the type (status) of alarm that is occurring in the servo drive. When the alarm does not occur, it will display 0000H. Do not display warnings.																					
		<table border="1"> <thead> <tr> <th>Bit</th> <th>Contents</th> </tr> </thead> <tbody> <tr> <td>0</td> <td rowspan="4">Not support</td> </tr> <tr> <td>1</td> </tr> <tr> <td>2</td> </tr> <tr> <td>3</td> </tr> <tr> <td>4</td> <td>AL status code defined alarm occured*1</td> </tr> <tr> <td>5</td> <td>Not support</td> </tr> <tr> <td>6</td> <td>Reserved</td> </tr> <tr> <td>7</td> <td>AL status code undefined alarm occured*2</td> </tr> </tbody> </table>	Bit	Contents	0	Not support	1	2	3	4	AL status code defined alarm occured*1	5	Not support	6	Reserved	7	AL status code undefined alarm occured*2						
Bit	Contents																						
0	Not support																						
1																							
2																							
3																							
4	AL status code defined alarm occured*1																						
5	Not support																						
6	Reserved																						
7	AL status code undefined alarm occured*2																						
		*1: "AL status code defined alarm" refers to abnormal communication association of EtherCAT E-800~7, E-810~7, E-850~7. *2: "AL status code undefined alarm" refers to abnormal communication association of EtherCAT E-880~7 and abnormal except EtherCAT communication association.																					
1008h	00h	Manufacturer Device name	-	-	ro	TxPDO	All																
		Represents the device name.																					
1009h	00h	Manufacturer Hardware version	-	-	ro	TxPDO	All																
		Indicates the hardware version.																					
Index	Sub-index	Name/Description	Range	DateType	Access	PDO	Op-mode																
1018h	00h	Number of entries	0~255	U8	ro	TxPDO	All																
		Represents the object subindexes. The value is fixed to 04H.																					
	01h	vendor ID	0~4294967295	U32	ro	TxPDO	All																
		Indicates the manufacturer ID of EtherCAT. The value is fixed to 00000556h.																					
	02h	product code	0~4294967295	U32	ro	TxPDO	All																
		Represents the product code. The value is 10305070h.																					
03h	Revision umber	0~4294967295	U32	ro	TxPDO	All																	
	Indicates the product version number. The value is 02040608h.																						
04h	Divece type	0~4294967295	U32	ro	TxPDO	All																	
	Indicates the product serial number. The value is 00000000h.																						

8.2.3 Sync manager communication type(1C00h)

The action mode assigned to each SyncManager is set by 1C00h object.

The value is fixed for the servo driver.

Index	Sub-index	Name/Description	Range	DateType	Access	PDO	Op-mode
1C00h	00h	Number of used sync manager channels	0~255	U8	ro	TxPDO	All
		Represents the object subindexes. The value is fixed to 04H.					
1C00h	01h	Communication type sync manager 0	0~4	U8	ro	TxPDO	All
		Set the purpose of SYNC Manager 0. 0: unused 1: Mailbox receive message (master station→slave station) 2: Mailbox send message (slave station→master station) 3: RxPDO (master station→slave station) 4: TxPDO (slave station→master station) Because SYNC Manager0 uses mailbox to receive messages, the value is fixed to 1.					

	02h	Communication type sync manager 1	0~4	U8	ro	TxPDO	All
	Set the purpose of SYNC Manager 1. 0: unused 1: Mailbox receive message (master station→slave station) 2: Mailbox send message (slave station→master station) 3: RxPDO (master station→slave station) 4: TxPDO (slave station→master station) Because SYNC Manager1 uses mailbox to send messages, the value is fixed to 2.						
	03h	Communication type sync manager 2	0~4	U8	ro	TxPDO	All
Set the purpose of SYNC Manager 2. 0: unused 1: Mailbox receive message (master station→slave station) 2: Mailbox send message (slave station→master station) 3: RxPDO (master station→slave station) 4: TxPDO (slave station→master station) Because SYNC Manager2 uses Process data output (RxPDO), the value is fixed to 3.							
	04h	Communication type sync manager 3	0~4	U8	ro	TxPDO	All
	Set the purpose of SYNC Manager 3. 0: unused 1: Mailbox receive message (master station→slave station) 2: Mailbox send message (slave station→master station) 3: RxPDO (master station→slave station) 4: TxPDO (slave station→master station) Because SYNC Manager3 uses Process data output (RxPDO), the value is fixed to 4.						

8.2.4 PDO mapping

1. PDO distribution object (1C12h ~ 1C13h)

The table for PDO mapping allocated by the syncmanager is set by the objects 1C12h to 1C13h.

Index	Sub-index	Name/Description	Range	DateType	Access	PDO	Op-mode
1C12h	00h	Number of assigned PDOs	0~4	U8	rw	NO	All
		Represents the subindexes for this object.					
	01h	Assigned RxPDO 1	1600h~1603h	U16	rw	NO	All
		Specifies the RxPDO mapping object.					
	02h	Assigned RxPDO 2	1600h~1603h	U16	rw	NO	All
		Specifies the RxPDO mapping object.					
	03h	Assigned RxPDO 3	1600h~1603h	U16	rw	NO	All
		Specifies the RxPDO mapping object.					
04h	Assigned RxPDO 4	1600~1603	U16	rw	NO	All	
	Specifies the RxPDO mapping object.						
1C13h	00h	Number of assigned PDOs	0~4	U8	rw	NO	All
		Represents the object subindexes. The value is fixed to 04H.					
	01h	Assigned TxPDO 1	1A00h~1A03h	U16	rw	NO	All
		Specifies the TxPDO mapping object.					
	02h	Assigned TxPDO 2	1A00h~1A03h	U16	rw	NO	All
		Specifies the TxPDO mapping object.					
	03h	Assigned TxPDO 3	1A00h~1A03h	U16	rw	NO	All
		Specifies the TxPDO mapping object.					
04h	Assigned TxPDO 4	1A00h~1A03h	U16	rw	NO	All	
	Specifies the TxPDO mapping object.						

Sub-index 01h-04h of 1C12h and 1C13h can only be changed when the ESM state is PreOP and sub-index 00h = 0. Other status will return port code (06010003h).

After the settings changed, set the Sub-index number of Sub-index 00h. PDO allocation object settings are reflected by changing ESM status to SafeOP.

2.PDO mapping object (1600h~1603h, 1A00h~1A03h)

As a table for PDO mapping objects, 1600h-1603h for RxPDO and 1A00h-1A03h for TxPDO can be used. After subindex 01h, it represents the information of the mapped application layer object.

Index	Sub-Index	Name/Description	Range	DateType	Access	PDO	Op-mode	
1600h	00h	Number of entries	0~4294967295	U8	rw	NO	All	
		Represents the subindexes for this object.						
	01h	1st receive PDO mapped	0~4294967295	U32	rw	NO	All	
		Set the first mapping object.						
		bit	31 ...16	15 ...8	7 ...0			
		Index number	Sub-index number	Bit length				
	02h	2nd receive PDO mapped	0~4294967295	U32	rw	NO	All	
		The setting method is same to Subindex01h.						
	03h	3rd receive PDO mapped	0~4294967295	U32	rw	NO	All	
		The setting method is same to Subindex01h.						
	04h	4th receive PDO mapped	0~4294967295	U32	rw	NO	All	
		The setting method is same to Subindex01h.						
	05h	5th receive PDO mapped	0~4294967295	U32	rw	NO	All	
		The setting method is same to Subindex01h.						
06h	6th receive PDO mapped	0~4294967295	U32	rw	NO	All		
	The setting method is same to Subindex01h.							
...	
18h	24th receive PDO mapped	0~4294967295	U32	rw	NO	All		
	The setting method is same to Sub-index01h.							
1601h	-	Receive PDO mapping 2, Sub-index specification is same to 1600h.						
1602h	-	Receive PDO mapping 3, Sub-index specification is same to 1600h.						
1603h	-	Receive PDO mapping 4, Sub-index specification is same to 1600h.						

Do not map duplicate objects. The change of repeated setting is not guaranteed.

Sub-index 01h-18h of 1600h-1603h can only be changed when the ESM state is PreOP and Sub-index 00h = 0. Other status will return Abort Code (06010003h).

After the settings changed, set the Sub-index number of Sub-index 00h. PDO allocation object settings are reflected by changing ESM status to SafeOP.

Index	Sub-Index	Name/Description	Range	DateType	Access	PDO	Op-mode	
1A00h	00h	Number of entries	0~4294967295	U8	rw	NO	All	
		Represents the subindexes for this object.						
	01h	1st transmit PDO mapped	0~4294967295	U32	rw	NO	All	
		Set the first mapping object.						
		bit	31 ...16	15 ...8	7 ... 0			
		Index number	Sub-index number	Bit length				
	02h	2nd transmit PDO mapped	0~4294967295	U32	rw	NO	All	
		The setting method is same to Subindex01h.						
	03h	3rd transmit PDO mapped	0~4294967295	U32	rw	NO	All	
		The setting method is same to Subindex01h.						
	04h	4th transmit PDO mapped	0~4294967295	U32	rw	NO	All	
		The setting method is same to Subindex01h.						
	05h	5th transmit PDO mapped	0~4294967295	U32	rw	NO	All	
		The setting method is same to Subindex01h.						
06h	6th transmit PDO mapped	0~4294967295	U32	rw	NO	All		
	The setting method is same to Subindex01h.							
...	
18h	24th transmit PDO mapped	0~4294967295	U32	rw	NO	All		
	The setting method is same to Subindex01h.							
1A01h	-	Transmit PDO mapping 2, Subindex specification is same to 1600h.						
1A02h	-	Transmit PDO mapping 3, Subindex specification is same to 1600h.						

1A03h	-	Transmit PDO mapping 4, Subindex specification is same to 1600h.
-------	---	--

Do not map duplicate objects. The change of repeated setting is not guaranteed.

Subindex 01h-18h of 1A00h-1A03h can only be changed when the ESM state is PreOP and Subindex00h = 0. Other status will return Abort Code (06010003h).

After the settings changed, set the Subindex number of Subindex00h. PDO allocation object settings are reflected by changing ESM status to SafeOP.

8.2.5 Sync manager 2/3 synchronization (1C32h, 1C33h)

Sync manager2 setting is executed according to 1C32h (Sync manager 2 synchronization).

Sync manager3 setting is executed according to 1C33h (Sync manager 3 synchronization).

Sync manager 2 synchronization(1C32h)

Index	Sub-Index	Name / Description	Range	DateType	Access	PDO	Op-mode	
1C32	00h	Number of entries	0~20h	U8	ro	NO	All	
		Represents the number of subindexes for this object. The value is fixed at 20h.						
	01h	Sync mode	0-65535	U16	rw	NO	All	
		Set Sync Manager 2 synchronization mode. 00h:FreeRun(not synchronized) 01h:SM2(synchronized with SM 2 Event) 02h:DC SYNC0(synchronized with Sync0 Event)						
		02h	Cycle time	0~4294967295	U32	rw	NO	All
	Set Sync Manager period. Set one of 500000 (500µs), 1000000 (1ms), 2000000 (2ms), 4000000 (4ms). If set other value, it will show E-810 (Abnormal protection of synchronization cycle setting).							
03h	Shift time	0~4294967295	U32	rw	NO	All		
	Offset time.							
1C32	04h	Sync modes supported	0~65535	U16	ro	NO	All	
		Set the supported synchronization type. BIT0:FreeRun mode supported 0:not supported; 1:FreeRun mode supported This servo driver is set to 1. BIT1:SM synchronization mode supported 0:not supported; 1:SM2 event synchronization supported This servo driver is set to 1. BIT4-2:DC synchronization mode supported 000b:not supported 001b:DC sync0 event supported This servo driver is set to 001b. BIT6-5: output offset supported 00b:not supported 01b:local clock offset supported This servo driver is set to 00b. BIT15-7:Reserved						
		05h	Minimum cycle time	0~4294967295	U32	ro	NO	All
			The minimum value of the communication cycle that can be set.					
		06h	Calc and copy time	0~4294967295	U32	ro	NO	All
			From SM2 event, SYNC0 event to ESC read completion time. This time can also be extended when there is a deviation in the signal.					
		08h	Command	0~65535	U16	ro	NO	All
			Not support					
		09h	Delay time	0~4294967295	U32	ro	NO	All
			Not support					
0Ah	Sync0 cycle time	0~4294967295	U16	ro	NO	All		
	When DC SYNC0 (1C32h-01h=02h), ESC register 09A0h value is set. Except DC SYNC0, please set to 0.							
0Bh	Cycle time too small	0~65535	U16	ro	NO	All		
	Not support							
0Ch	SM-event missed	0~65535	U16	ro	NO	All		

Index	Sub-Index	Name / Description	Range	DateType	Access	PDO	Op-mode
		Not support					
	0Dh	Shift time too short	0~65535	U16	ro	NO	All
		Not support					
	0Eh	RxPDO toggle failed	0~65535	U16	rw	NO	All
		Not support					
	20h	Sync error	0~1	BOOL	ro	NO	All
		Sync error					

This setting value is a reference value, not a guaranteed value.

Sync manager 3 synchronization (1C33h)

Index	Sub-Index	Name/Description	Range	DateType	Access	PDO	Op-mode
1C33h	00h	Number of entries	0~20h	U8	ro	NO	All
		Represents the subindexes for this object. The value is fixed at 20h.					
	01h	Sync mode	0~65535	U16	rw	NO	All
		Set Sync Manager 3 synchronization mode. 00h:FreeRun (not synchronized) 01h:SM2 (synchronized with SM 2 Event) 02h:DC SYNC0 (synchronized with Sync0 Event) Set Sync Manager 2 synchronization mode. 00h:FreeRun (not synchronized) 01h:SM2(synchronized with SM 2 Event) 02h:DC SYNC0(synchronized with Sync0 Event)					
	02h	Cycle time	0~4294967295	U32	rw	NO	All
		Set Sync Manager period. Set one of the 500000 (500us), 1000000(1ms), 2000000(2ms), 4000000(4ms). If set other value,it will show E-810 (Abnormal protection of synchronization cycle setting).					
	03h	Shift time	0~4294967295	U32	rw	NO	All
		Offset time					
	04h	Sync modes supported	0~65535	U16	ro	NO	All
		Set the supported synchronization type. BIT0: FreeRun mode supported 0:not supported; 1:FreeRun mode supported This servo driver is set to 1. BIT1:SM synchronization mode supported 0:not supported; 1:SM2 event synchronization supported This servo driver is set to 1. BIT4-2:DC synchronization mode supported 000b:not supported 001b:DC sync0 event supported This servo driver is set to 001b. BIT6-5:output offset supported 00b:not supported 01b:local clock offset supported This servo driver is set to 00b. BIT15-7:Reserved					
1C33h	05h	Minimum cycle time	0~4294967295	U32	ro	NO	All
		The minimum value of the communication cycle that can be set.					
	06h	Calc and copy time	0~4294967295	U32	ro	NO	All
		From SM2 event, SYNC0 event to ESC read completion time. This time can also be extended when there is a deviation in the signal.					
	08h	Command	0~65535	U16	ro	NO	All
		Not support					
	09h	Delay time	0~4294967295	U32	ro	NO	All
		Not support					
	0Ah	Sync0 cycle time	0~4294967295	U16	ro	NO	All
		The same value to 1C32h-0Ah.					

Index	Sub-Index	Name/Description	Range	DateType	Access	PDO	Op-mode
	0Bh	Cycle time too small	0~65535	U16	ro	NO	All
		Not support					
	0Ch	SM-event missed	0~65535	U16	ro	NO	All
		Not support					
	0Dh	Shift time too short	0~65535	U16	ro	NO	All
		Not support					
	0Eh	RxPDO toggle failed	0~65535	U16	rw	NO	All
		Not support					
	20h	Sync error	0~1	BOOL	ro	NO	All
		Sync error					

This setting value is a reference value, not a guaranteed value.

1)DC (SYNC0 event synchronization)

Synchronization method	Features
Based on the time of the first axis synchronize time information of other slave stations	High-precision Compensation treatment shall be carried out at the main station side

The specification of DC synchronous mode in this servo driver is as follows:

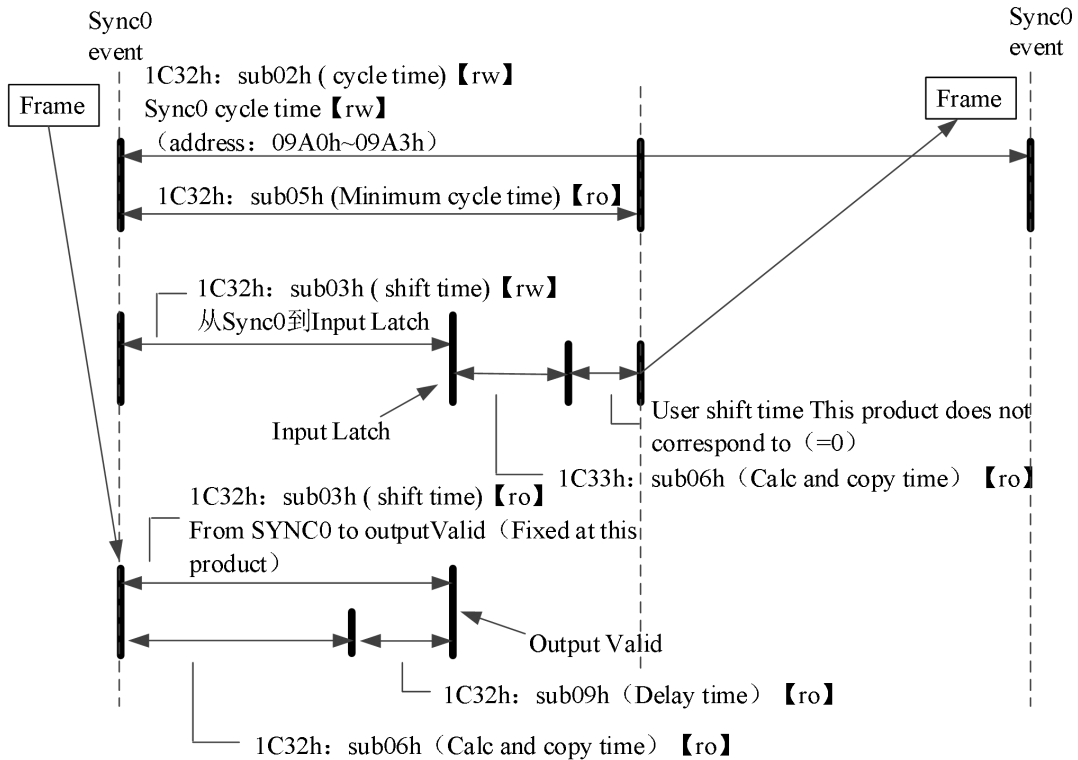

2)SM2 (SM2 event synchronization)

Synchronization method	Features
Synchronize with RxPDO receiving time	No transmission delay compensation accuracy difference Ensure the transmission time at the upper device side (special hardware, etc.)

The specification of SM2 synchronous mode in this servo driver is as follows:

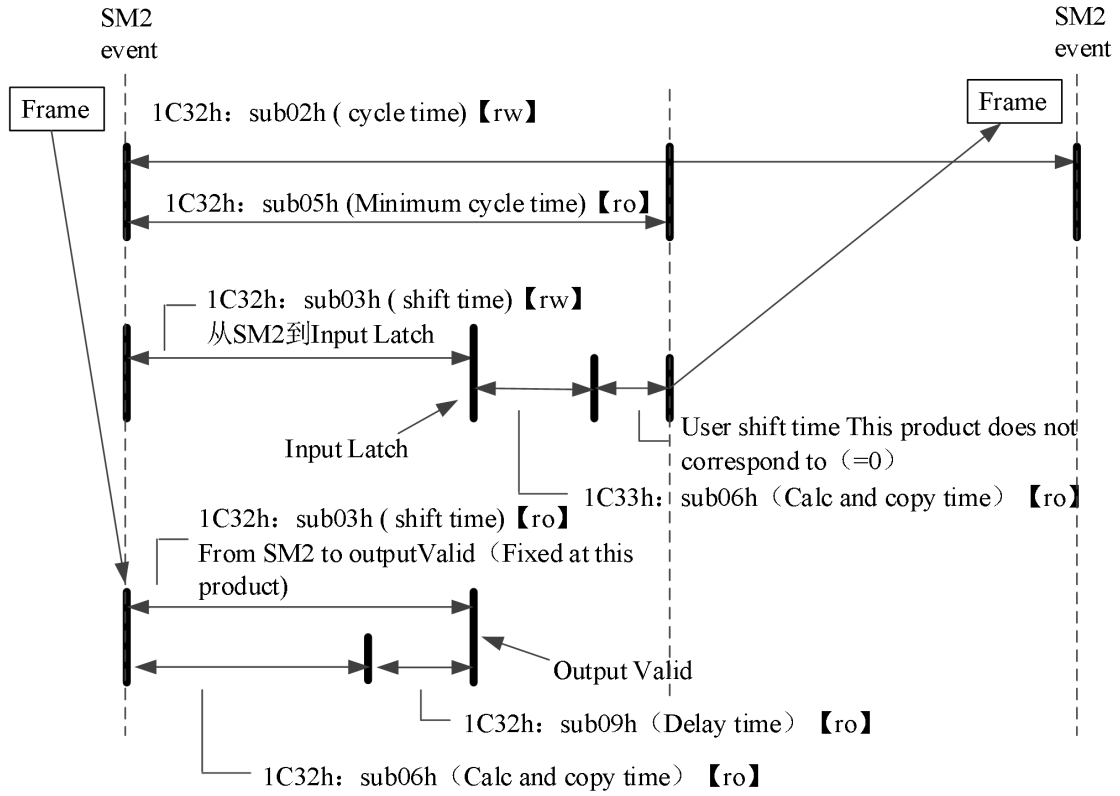

8.3 Servo parameter area (0x2000~0x2FFF)

8.3.1 Object list

The object of 2000h – 2FFFh is distributed servo parameters. (servo parameter please refer to appendix of this manual).

Index	Sub-index	Name
2000h	00h	P0-00
2001h	00h	P0-01
2002h	00h	P0-02
2003h	00h	P0-03
...
205Fh	00h	P0-95
2100h	00h	P1-00
2101h	00h	P1-01
2102h	00h	P1-02
2103h	00h	P1-03
...
214Ah	00h	P1-74
2200h	00h	P2-00
2201h	00h	P2-01
2202h	00h	P2-02
2203h	00h	P2-03
...
2263h	00h	P2-99
2300h	00h	P3-00
2301h	00h	P3-01
2302h	00h	P3-02
2303h	00h	P3-03
...
232Eh	00h	P3-46

Index	Sub-index	Name
3000h	00h	U0-00
3001h	00h	U0-01
3002h	00h	U0-02
...
3061h	00h	U0-97

Index	Sub-index	Name
4000h	00h	F0-00
...
4106h	00h	F1-06

Index	Sub-index	Name
2500h	00h	P5-00
2501h	00h	P5-01
2502h	00h	P5-02
2503h	00h	P5-03
...
2547h	00h	P5-71
2700h	00h	P7-00
2701h	00h	P7-01
2702h	00h	P7-02
2703h	00h	P7-03
...
2715h	00h	P7-21
2800h	00h	P8-00
2801h	00h	P8-01
2802h	00h	P8-02
2803h	00h	P8-03
...
281Ah	00h	P8-26

Index	Sub-index	Name
3100h	00h	U1-00
3101h	00h	U1-01
...

8.3.2 Object overview

For example: P1-04, EtherCAT distributes to 2104h.

P3-10, EtherCAT distributes to 230Ah.

12-15bit : 2 represents servo parameter area

8-11 bit : 0-F represents group P number

0-7 bit : 00-FF represents parameters in group P

8.4 Driver Profile area(0x6000~0x6FFF)

8.4.1 Object list

Index	Sub-index	Name
603Fh	00h	Abort connection option code
6040h	00h	Control word
6041h	00h	Status word
605Ah	00h	Quick stop option code
605Bh	00h	Shutdown option code
605Bh	00h	Disable operation option code
605Bh	00h	Halt option code
605Eh	00h	Fault reaction option code
6060h	00h	Modes of operation
6061h	00h	Modes of operation display
6062h	00h	Position demand value
6063h	00h	Position actual internal value
6064h	00h	Position actual value
6065h	00h	Following error window
6066h	00h	Following error time out
6067h	00h	Position window
6068h	00h	Position window time
6069h	00h	Velocity sensor actual value
606Bh	00h	Velocity demand value
606Ch	00h	Velocity actual value
606Dh	00h	Velocity window
606Eh	00h	Velocity window time
606Fh	00h	Velocity threshold
6070h	00h	Velocity threshold time
6071h	00h	Target torque
6072h	00h	Max torque
6073h	00h	Max current
6074h	00h	Torque demand
6075h	00h	Motor rated current
6076h	00h	Motor rated torque
6077h	00h	Torque actual value
6078h	00h	Current actual value
6079h	00h	DC link circuit voltage
607Ah	00h	Target position
607Bh	-	Position rang limit
	00h	Number of entries
	01h	Min position range limit
	02h	Max position range limit
607Ch	00h	Home offset
607Dh	-	Software position limit
	00h	Number of entries
	01h	Min position limit
	02h	Max position limit
606Eh	00h	Polarity
607Fh	00h	Max Profile velocity
6080h	00h	Max motor speed
6081h	00h	Profile velocity
6082h	00h	End velocity
6083h	00h	Profile acceleration
6084h	00h	Profile deceleration
6085h	00h	Quick stop deceleration
6086h	00h	Motion profile type

Index	Sub-index	Name
6087h	00h	Torque slope
6088h	00h	Torque profile type
608Fh	-	Position encoder resolution
	00h	Number of entries
	01h	Encoder increments
	02h	Motor revolutions
6091h	-	Gear ratio
	00h	Number of entries
	01h	Motor revolutions
	02h	Shaft revolutions
6092h	-	Feed constant
	00h	Number of entries
	01h	Feed
	02h	Shaft revolutions
6098h	00h	Homing method
6099h	-	Homing speeds
	00h	Number of entries
	01h	Speed during search for switch
	02h	Speed during search for zero
609Ah	00h	Homing acceleration
60A3h	00h	Profile jerk use
60A4h	-	Profile jerk
	00h	Number of entries
	01h	Profile jerk1
	02h	Profile jerk2
60B0h	00h	Position offset
60B1h	00h	Velocity offset
60B2h	00h	Torque offset
60B8h	00h	Touch probe function
60B9h	00h	Touch probe status
60BAh	00h	Touch probe pos1 pos value
60BBh	00h	Touch probe pos1 neg value
60BCh	00h	Touch probe pos2 pos value
60BDh	00h	Touch probe pos2 neg value
60C2h	-	Interpolation time period
	00h	Number of entries
	01h	Interpolation time period value
	02h	Interpolation time index
60C5h	00h	Max acceleration
60C6h	00h	Max deceleration
60E3h	-	Supported Homing method
	00h	Number of entries
	01h	1st supported Homing method

	20h	32nd supported Homing method
60F2h	00h	Positioning option code
60F4h	00h	Following error actual value
60FAh	00h	Control effort
60FCh	00h	Position demand internal value
60FDh	00h	Digital inputs
60FEh	-	Digital outputs
	00h	Number of entries
	01h	Physical outputs
	02	Bit mask
60FEh	00h	Target velocity
6502h	00h	Supported drive modes

8.4.2 PDS(Power Drive Systems)specification

According to the user command or abnormal detection, the state transition of the PDS associated with the power control of the servo driver is defined as follows.

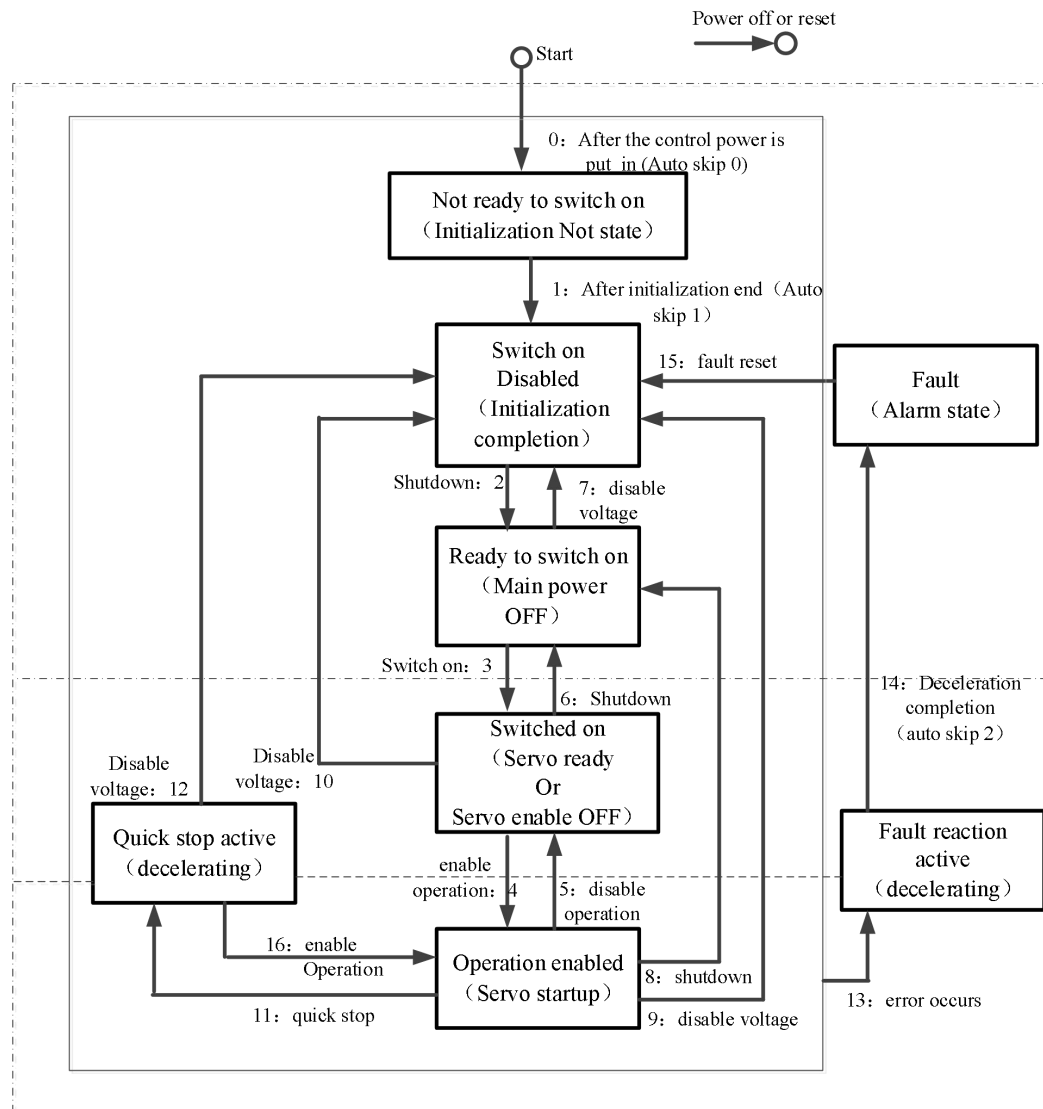

After migrating to Operation enabled, please increase the time to more than 100ms and input the action command. The following table shows the PDS state migration events (migration conditions) and actions during migration. For the migration of PDS, the status migration is performed at the same time as the handshake is obtained (through 6041h: Statusword, confirm the status has been converted, and then send the next migration instruction).

PDS conversion	Event	Action
0 Auto skip 0	After the power supply is put into operation, or after the application layer is reset, it will automatically migrate.	After the power supply is put into operation, or after the application layer is reset, it will automatically migrate.
1 Auto skip 1	Automatic conversion after initialization.	Communications are established.
2 Shut down	The condition of receiving the Shutdown instruction.	Nothing special
3 Switch on	When the power supply is on, the condition of receiving the Switch on command.	Nothing special
4 Enable operation	The condition of receiving the Enable operation instruction.	The driver function is effective. In addition, all previous Set point data are cleared.
5 Disable operation	The condition of receiving the Disable operation instruction.	Invalid driver function.

6	Shutdown	When the power supply is on, the condition of receiving Shutdown command. Check out the condition of the power supply is off.	Nothing special
7	Disable voltage	the condition of receiving Disable voltage instruction. the condition of receiving Quick stop instruction. When ESM status is PreOP, SafeOP, OP, the condition of migrating to Init.	Nothing special
8	Shutdown	When the power supply is on, the condition of receiving the Shutdown instruction.	Driver function is invalid
9	Disable voltage	The condition of receiving the Disable voltage command.	Driver function is invalid
10	Disable voltage	The condition of receiving the Disable voltage command. The condition of receiving the Quick stop command. When ESM status is PreOP, SafeOP, OP, the condition of migrating to Init.	Nothing special
11	Quick stop	The condition of receiving Quick stop command.	Execute Quick stop function.
12	Disable voltage	When Quick stop selected code is 1, 2, 3 and the condition of Quick stop action completion. When Quick stop code is 5, 6, 7, and the action of Quick stop is completed, the condition of receiving Disable voltage command. Check out the condition of power OFF.	Driver function is invalid.
13	Error occurs	Abnormal detection.	Execute Fault reaction function.
14	Auto skip 2	After the abnormal detection and deceleration processing is completed, it will be migrated automatically.	Driver function is invalid.
15	Fault reset	After the removal of abnormal factors, the condition of receiving the Fault reset instruction.	The fault factor does not exist, Excute the reset of the Fault state.
16	Enable operation	When Quick stop selected code is 5, 6, 7, the condition of receiving Enable operation command.	Driver function is effective.

8.4.3 Controlword (6040h)

The command to control the slave station (servo driver) such as PDS status migration is set through 6040h (control word).

Index	Sub-index	Name	Range	Data type	Access	PDO	Op-mode																																
6040h	00h	Controlword	0~65535	U16	rw	RxPDO	All																																
Set the servo driver control command for PDS status conversion.																																							
Bit information																																							
<table border="1" style="width:100%; border-collapse: collapse;"> <tr> <td style="width:12.5%;">15</td> <td style="width:12.5%;">14</td> <td style="width:12.5%;">13</td> <td style="width:12.5%;">12</td> <td style="width:12.5%;">11</td> <td style="width:12.5%;">10</td> <td style="width:12.5%;">9</td> <td style="width:12.5%;">8</td> </tr> <tr> <td colspan="6" style="text-align:center;">R</td> <td style="text-align:center;">oms</td> <td style="text-align:center;">h</td> </tr> <tr> <td style="width:12.5%;">7</td> <td style="width:12.5%;">6</td> <td style="width:12.5%;">5</td> <td style="width:12.5%;">4</td> <td style="width:12.5%;">3</td> <td style="width:12.5%;">2</td> <td style="width:12.5%;">1</td> <td style="width:12.5%;">0</td> </tr> <tr> <td style="text-align:center;">fr</td> <td colspan="3" style="text-align:center;">R</td> <td style="text-align:center;">eo</td> <td style="text-align:center;">qs</td> <td style="text-align:center;">ev</td> <td style="text-align:center;">so</td> </tr> </table>								15	14	13	12	11	10	9	8	R						oms	h	7	6	5	4	3	2	1	0	fr	R			eo	qs	ev	so
15	14	13	12	11	10	9	8																																
R						oms	h																																
7	6	5	4	3	2	1	0																																
fr	R			eo	qs	ev	so																																
r = reserved(not corresponded)				fr = fault reset																																			
oms = operation mode specific (control mode is based on bit)				eo = enable operation																																			
h = halt				qs = quick stop																																			
so = switch on				ev = enable voltage																																			

Command	bits of the controlword					PDS conversion
	bit7	bit3	bit2	bit1	bit0	
	Fault reset	Enable operation	quick stop	Enable voltage	Switch on	
Shutdown	0	-	1	1	0	2,6,8

Switch on	0	0	1	1	1	3
Switch on + Enable operation	0	1	1	1	1	3+4
Enable operation	0	1	1	1	1	4,16
Disable voltage	0	-	-	0	-	7,9,10,12
Quick stop	0	-	0	1	-	7,10,11
Disable operation	0	0	1	1	1	5
Fault reset	0->1	-	-	-	-	13

① Bit logic of quick stop command is effective under 0.

Please note that other bit logic and the opposite actions are performed.

② Bit8 (halt): When it is 1, motor decelerating and stop are performed through 605Dh (Halt select code)

After the pause, the enable must be turned off to restart the action.

③ Bit9, 6-4 (operation mode specific):

The following shows the change of OMS bit inherent in the control mode (OP mode). (for details, please refer to the chapter of related objects of each control mode.)

Op-mode	Bit9	Bit6	Bit5	Bit4
pp	change on set-point	absolute / relative	change set immediately	new set-point
pv	-	-	-	-
tq	-	-	-	-
hm	-	-	-	start homing
csp	-	-	-	-
csv	-	-	-	-
cst	-	-	-	-

8.4.4 Statusword (6041h)

The status confirmation of slave station (servo driver) is carried out by 6041h (status word).

Index	Sub-index	Name	Range	Data type	Access	PDO	Op-mode								
6041h	00h	Status word	0~65535	U16	ro	TxPDO	All								
Indicates the status of the servo driver.															
Bit information															
15		14		13		12		11		10		9		8	
r		oms		ila		oms		rm		r					
7		6		5		4		3		2		1		0	
w		sod		qs		ve		f		oe		so		rsto	
r = reserved (not corresponded)				w = warning											
sod = switch on disabled				qs = quick stop				ve = voltage enabled							
oms = operation mode specific (control mode is based on bit)				ila = internal limit active				f = fault							
oe = operation enabled				rm = remote				so = switched on							
rtso = ready to switch on															

Bit6,5,3-0 (switch on disabled/quick stop/fault/operation enabled/switched on/ready to switch on): confirm the PDS status based on this bit. The following is the relationship between status and related bit.

StatusWord	PDS State
xxxx xxxx x0xx 0000 b	Not ready to switch on Initialize incompleted state
xxxx xxxx x1xx 0000 b	Switch on disabled Initialize completed state
xxxx xxxx x01x 0001 b	Ready to switch on Initialize completed state
xxxx xxxx x01x 0011 b	Switched on Servo enable OFF/servo ready
xxxx xxxx x01x 0111 b	Operation enabled Servo enable ON
xxxx xxxx x00x 0111 b	Quick stop active Stop at once
xxxx xxxx x0xx 1111 b	Fault reaction active Abnormal (alarm) judgment
xxxx xxxx x0xx 1000 b	Fault Abnormal (alarm) state

Bit4 (voltage enabled) = 1: power supply is ON PDS.

Bit5 (quick stop) = 0: PDS receives quick stop request. The bit logic of quick stop is effective under 0. Please note that other bit logic and the opposite actions are performed.

Bit7 (warning) = 1, warning occurs. When warning, PDS status will not change and motor will continue to operate.

Bit9 (remote) = 0(local), the status that 6040(Controlword) cannot operate.

Bit9 =1(remote), the status that 6040(Controlword) can operate. The ESM state changes to 1 when the state transforms above PreOP.

Below bit13,12,10 (operation mode specific): change of OMS bit inherent in control mode. (for details, please refer to the chapter of related objects of each control mode.)

Op-mode	Bit13	Bit12	Bit10
pp	following error	set-point acknowledge	target reached
pv	-	speed	target reached
tq	-	-	target reached
hm	homing error	homing attained	target reached
csp	following error	drive follows command value	-
csv	-	drive follows command value	-
cst	-	drive follows command value	-

Bit11(internal limit active): the main reason for the internal limit is that the bit11 (internal limit active) of 6041h (status word) changes to 1.

Bit15,14(reserved): This bit is not used (fixed 0).

8.5 Control mode setting

8.5.1 Supported drive modes (6502h)

This servo driver can confirm the supported modes of operation according to 6502h (supported drive modes).

Index	Sub-index	Name / Description	Range	Data type	Access	PDO	Op-mode
6502h	00h	Supported drive modes	0~4294967295	U32	ro	TxPDO	All
supported control mode (Mode of operation). When the value is 1, it represents the supported mode in this mode. Bit information							
		31...16	15...10	9	8		
		r	r	cst	csv		
		0	0	1	1		
7	6	5	4	3	2	1	0
csp	r	hm	r	tq	pv	r	pp
1	0	1	0	1	1	0	1
Bit	Mode of operation					Abbr.	Corresponding
0	Profile position mode (Profile position control mode)					pp	YES
2	Profile velocity mode(Profile speed control mode)					pv	YES
3	Torque profile mode(Profile torque control mode)					tq	YES
5	Homing mode(origin reset position mode)					hm	YES
7	Cyclic synchronous position mode(Cyclic position control mode)					csp	YES
8	Cyclic synchronous velocity mode(Cyclic speed control mode)					csv	YES
9	Cyclic synchronous torque mode (Cyclic torque control mode)					cst	YES

8.5.2 Modes of operation(6060h)

Set the control mode through 6060h (Modes of operation).

Index	Sub-index	Name/Description	Range	DateType	Access	PDO	Op-mode
6060h	00h	Mode of operation	-128~127	I8	rw	RxPDO	All
Set the control mode of servo driver. Non corresponding control mode setting is inhibited.							
		bit	Mode of operation	Abbr.	Corresponding		
		-128~ -1	Reserved	-	-		
		0	No mode changed/No mode assigned (no control mode changed/no control mode distribution)	-	-		
		1	Profile position mode (Profile position control mode)	pp	YES		
		3	Profile velocity mode (Profile speed control mode)	pv	YES		
		4	Torque profile mode (Profile torque control mode)	tq	YES		
		6	Homing mode (origin reset position mode)	hm	YES		
		8	Cyclic synchronous position mode (Cyclic position control mode)	csp	YES		
		9	Cyclic synchronous velocity mode (Cyclic speed control mode)	csv	YES		
		10	Cyclic synchronous torque mode(Cyclic torque control mode)	cst	YES		
		11~127	Reserved	-	-		

Because 6060h (modes of operation) is default = (no mode change / no mode assigned), please set the control mode value to be used after the power is put into operation. When the set value of 6060h is 0 and the set value of 6061h is 0, if the PDS state is migrated to Operation enabled, E-881 (control mode setting fault protection) occurs. After the initial state of 6060h = 0 (no mode assigned) is transferred to the supported control mode (PP, PV, TQ, HM, CSP, CSV, CST), set 6060h = 0 is seemed as "no mode changed", and the control mode can not be switched. (keep the previous control mode).

8.5.3 Modes of operation display(6061h)

The confirmation of the control mode inside the servo driver is performed according to 6061h (modes of operation display). After 6060h (modes of operation) is set, please confirm whether it is feasible to set this object action through detection.

Index	Sub-index	Name/Description	Range	DateType	Access	PDO	Op-mode
6061h	00h	Mode of operation display	-128~127	I8	ro	TxPDO	All
The current control mode.							
		bit	Mode of operation	Abbr.	Corresponding		
		-128~ -1	Reserved	-	-		
		0	No mode changed/No mode assigned (no control mode changed/no control mode distribution)	-	-		
		1	Profile position mode (Profile position control mode)	pp	YES		
		3	Profile velocity mode (Profile speed control mode)	pv	YES		
		4	Torque profile mode (Profile torque control mode)	tq	YES		
		6	Homing mode (origin reset position mode)	hm	YES		
		8	Cyclic synchronous position mode (Cyclic position control mode)	csp	YES		
		9	Cyclic synchronous velocity mode (Cyclic speed control mode)	csv	YES		
		10	Cyclic synchronous torque mode (Cyclic torque control mode)	cst	YES		
		11~127	Reserved	-	-		

9 Servo gain adjustment

9.1 Overview of servo gain adjustment

9.1.1 Overview and process

The servo driver needs to drive the motor as fast and accurately as possible to track the instructions from the upper computer or internal settings. In order to meet this requirement, the servo gain must be adjusted reasonably. Servo gain factory value is adaptive mode, but different machines have different requirements for servo responsiveness; the following figure is the basic process of gain adjustment, please adjust according to the current machine status and operation conditions.

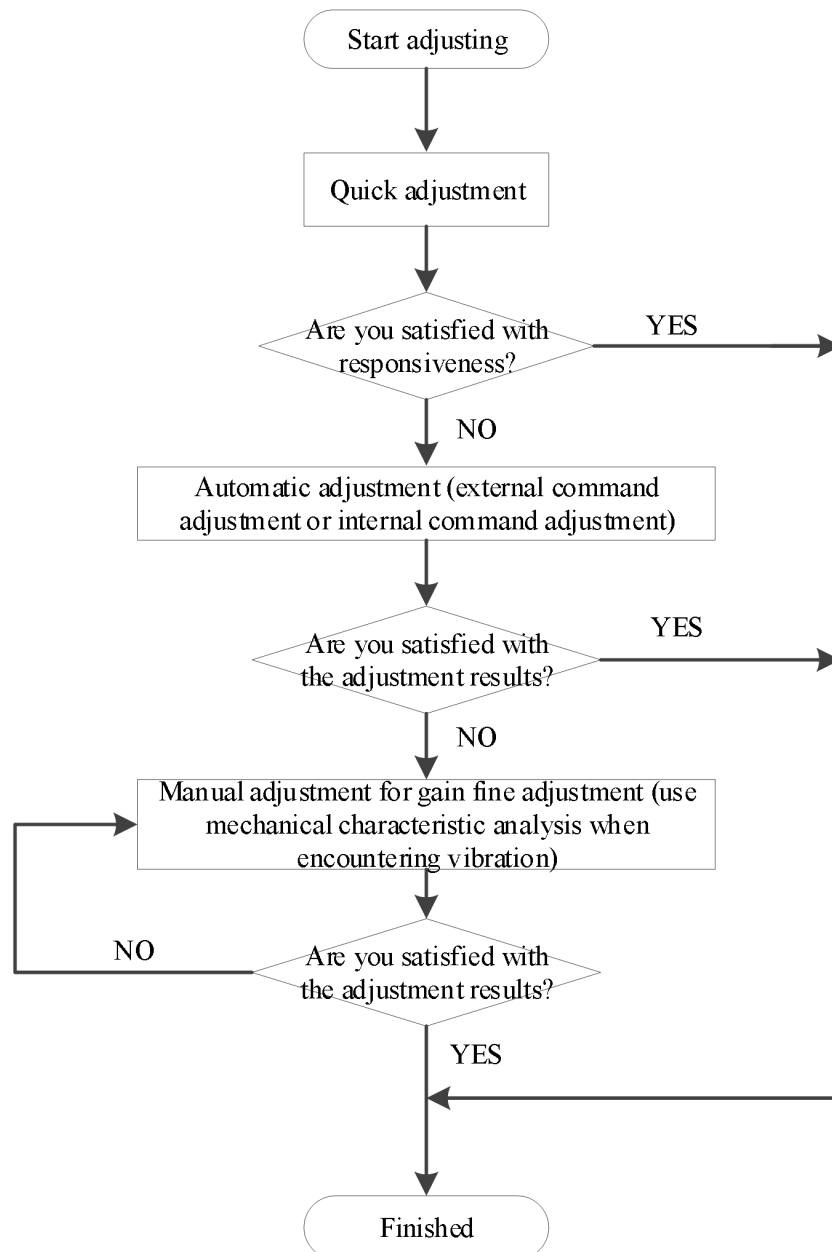

9.1.2 Differences between these adjustment modes

Adjustment modes are divided into adaptive and auto-tuning, and their control algorithms and parameters are independent. Among them, the auto-tuning mode is divided into three functions: fast adjustment, automatic adjustment and manual adjustment. The three functions are the same in essence but different in implementation. Refer to the corresponding chapters of each function.

Mode	Type	Parameters	Rigidity	Responsiveness	Related parameters
Adaptive	Automatic adaptation	P2-01.0=1	Middle	150ms	P2-05 adaptive speed loop gain P2-10 adaptive speed loop integral P2-11 adaptive position loop gain P2-07 adaptive inertia ratio P2-08 adaptive speed observer gain P2-12 adaptive stable max inertia ratio
Auto-tuning	Fast adjustment	P2-01.0=0	High	10 ~50ms	P0-07 First inertia ratio P1-00 Speed loop gain
	Automatic adjustment		High	10ms	P1-01 Speed loop integral P1-02 Position loop gain
	Manual adjusting		High	Determined by parameters	P2-35 Torque instruction filtering time constant 1 P2-49 Model loop gain

9.2 Rotary inertia presumption

9.2.1 Overview

Rotational inertia estimation is the function of automatic operation (forward and reverse) in the driver and estimate the load inertia in operation.

Rotational inertia ratio (the ratio of load inertia to motor rotor inertia) is a benchmark parameter for gain adjustment, and it must be set to the correct value as far as possible.

Parameter	Meaning	Default setting	Unit	Setting range	Modification	Effective
P0-07	First inertia ratio	500	%	0~50000	anytime	At once

9.2.2 Notes

Occasions where inertia cannot be presumed

- ◆ Mechanical systems can only operate in one direction

The occasion where inertia presumption is easy to fail

- ◆ Excessive load moment of inertia
- ◆ The running range is narrow and the travel is less than 0.5 circles.
- ◆ The moment of inertia varies greatly during operation.
- ◆ Mechanical rigidity is low and vibration occurs when inertia is presumed.

Notes of inertia presumption

- ◆ Since both directions are rotatable within the set range of movement, please confirm the range or direction of movement; and ensure that the load runs in a safe journey.
- ◆ If the presumed inertia under default parameters runs jitter, indicating that the present load inertia is too large. It is also possible to set the initial inertia to about twice the current one and execute again under larger loads.
- ◆ Driver inertia ratio recognition upper limit is 500 times (parameter upper limit is 20000). If the estimated inertia ratio is exactly 20000, it means that the inertia ratio has reached the upper limit and can not be used, please replace the motor with larger rotor inertia.

Other notes

- ◆ At present, the inertia switching function is not supported, and the second inertia ratio is invalid.
- ◆ The inertia ratio upper limit changes to 500 times for the driver firmware 3700 and higher version (parameter upper limit value is 50000).

9.2.3 Operation tool

The presumptive tools of load moment of inertia are driver panel and XinjeServo software.

Operation tool	Description
Driver panel	Driver firmware needs 3700 and higher version
XinjeServo software	All versions of software supported

Note: driver firmware version can be checked through U2-07.

9.2.4 Operation steps

Estimate the inertia through the driver panel

1. Parameter setting

Parameter	Setting	Default setting	Unit	Range	Modification	Effective
P2-15	Inertia configured trip	100	0.01 circle	1~300	Anytime	At once

P2-17	Inertia identification and internal instruction auto-tuning max speed	/	rpm	0~65535	Anytime	At once
P2-18	Inertia identification initial inertia ratio	500	%	1~20000	Anytime	At once

The recommended parameters of P2-17 are 500 rpm or more. Low instruction speed will lead to inaccurate identification of inertia ratio.

2. Execute the inertia identification

Before inertia identification, please confirm the direction of servo rotation by using F1-00 jog motion function. Initial direction of servo operation is determined by INC or DEC at the beginning of inertia identification.

Servo entering parameter F0-07 in BB state:

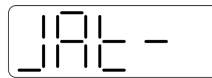

Press ENTER, servo is enabled:

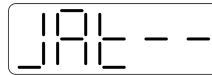

Press INC or DEC to run forward or reverse (select one of them):

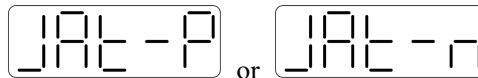

At this point, start action, under the condition of P0-05 = 0 (initial positive direction), if press INC, then turn forward and then reverse; if press DEC, turn reverse and then forward. If the inertia identification is successful, the load inertia ratio is prompted and written to P0-07 automatically after several forward and reverse operations. If the inertia identification error occurs, the error code will be displayed. Press STA/ESC key to exit the panel inertia identification operation.

■ Alarm for inertia identification of panel

Error code	Meaning	Reasons and solutions	Reasons
Err-1	Motor torque saturation	① Initial inertia is too small; in adaptive mode, switch to large inertia mode P2-03.3=1 or the initial inertia of inertia identification P2-18 set to 2 times of the present value. ② The maximum speed is too high (P2-17), but it is recommended not to be less than 500 rpm. Low instruction speed will lead to inaccurate identification of inertia ratio. ③ Torque limit too small (P3-28/29)	Initial inertia too small; Maximum speed too large; Torque limit too small
Err-2	Value error is too large when calculating the inertia	① The maximum speed limit is too small (P2-17), but it is recommended not to be less than 500 rpm. Low instruction speed will lead to inaccurate identification of inertia ratio. ② The presumed inertia trip is too small. It is suggested that the minimum for P2-15 should no be less than 50 (0.5 cycles). If the trip is too small, the identification of inertia ratio will be inaccurate. ③ mechanism friction too large ④ overshoot	The maximum speed limit is too small; the travel is too small; the friction of the mechanism is too large; the overrun occurs
Err-3	Driver internal trip calculation error	① The presumed inertia trip is too small. It is suggested that the minimum for P2-15 should no be less than 50 (0.5	Contact us

		cycles). If the trip is too small, the identification of inertia ratio will be inaccurate.	
Err-5	Unrestrained Vibration in the Process of Inertia Identification	Unhandled vibration occurs	Unhandled vibration occurs
Err-6	Driver is not currently in BB state	①Enable have been opened. P5-20 can be set to 0 first ②When the driver alarms, it will appear. Press ESC key to exit the auto-tuning interface to see if there is an alarm.	Will occur when enable is turned on or driver has alarm
Err-7	The driver alarms in the process of inertia identification	Driver has alarm, press ESC key to exit the auto-tuning interface, check the alarm code, first solve the alarm and then make inertia estimation.	Driver has alarm

Estimate the inertia through XinJeServo software

1. Click “Gain adjustment---Self tuning” on the main interface of XinjeServo

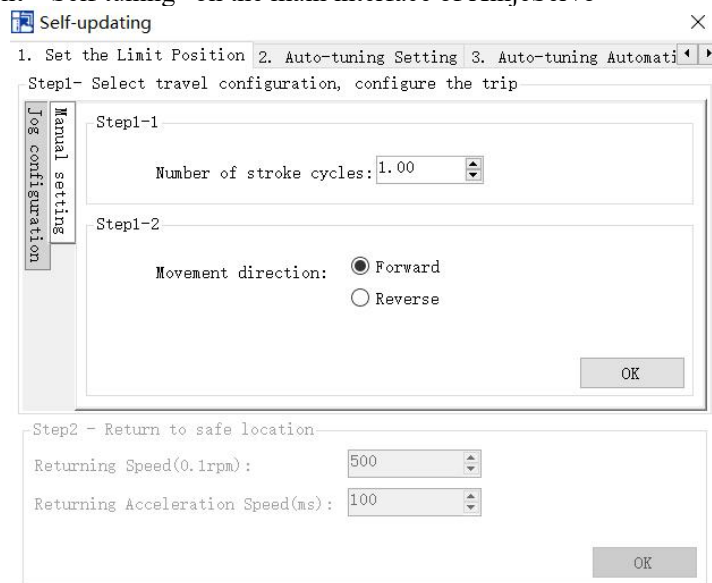

2. Choose **【Jog configuration】** or **【Manual setting】** to configure the trip.

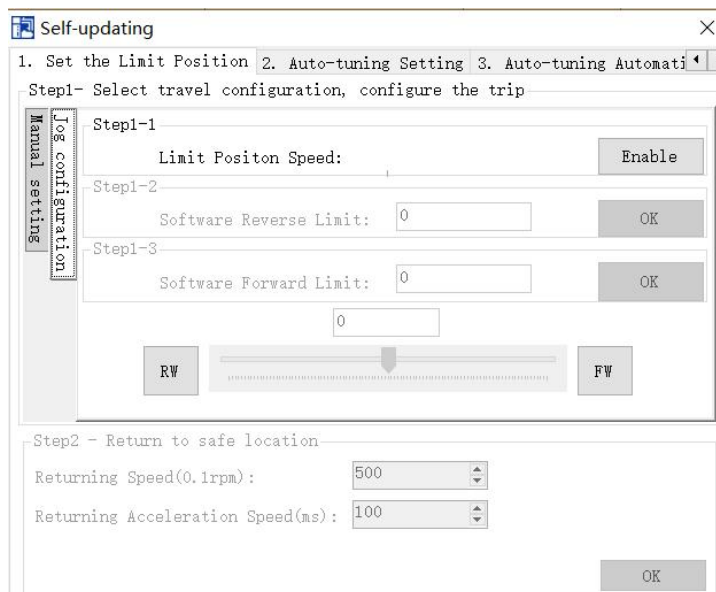

3. Auto-tuning configuration setting

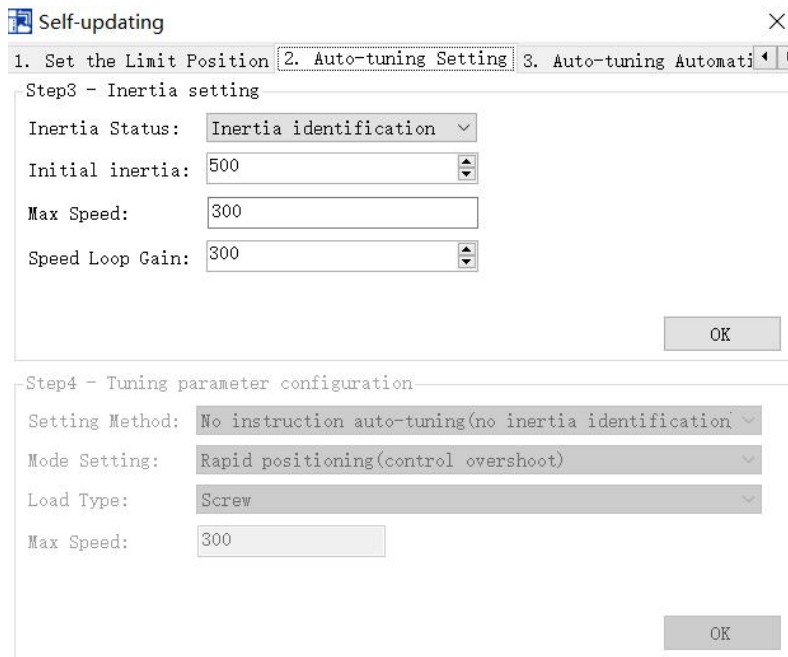

4. Click OK, Start to estimate inertia.

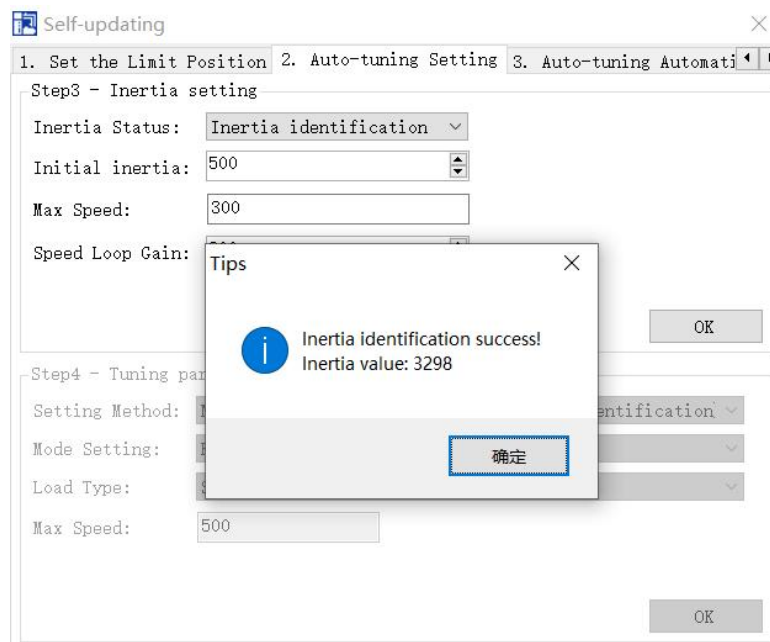

Note:

- (1) If the auto-tuning interface is closed directly, the driver only configures inertia ratio parameters.
- (2) The detailed steps of XinJeServo's presumptive inertia refer to XinJeServo's help document.

9.3 Fast adjustment

9.3.1 Overview

Fast adjustment needs to set the moment of inertia of load first, then turn off the adaptive function. If the inertia does not match, it will cause oscillation alarm. Servo firmware version 3640 and later versions support this function, and the version is viewed through U2-07. Fast adjustment of gain parameters belongs to auto-tuning mode.

9.3.2 Fast adjustment steps

1. Estimate the load inertia through servo driver panel or XinJeServo software, refer to chapter [9.2 Rotary inertia presumption](#);
2. Set the rigidity level P0-04

Note: P2-01.0 is the first bit of P2-01

P2-01=n. 0 0 1 0

9.3.3 Rigidity level corresponding gain parameters

- Rigidity level of 3700 and above firmware

P0-04 Rigidity level	P1-00 Speed loop gain	P1-01 Speed loop integral	P1-02 Position loop gain	P2-35 Torque instruction filter	P2-49(3700~3 720) Model loop gain	P2-49(3730 and above) Model loop gain
1	20	31831	20	100	50	50
2	50	12732	50	100	80	80
3	70	9094	70	100	90	90
4	80	7957	80	100	100	100
5	100	6366	100	100	100	120
6	120	5305	120	100	150	150
7	140	4547	140	100	150	200
8	160	3978	160	100	200	250
9	180	3536	180	100	250	310
10	200	3183	200	100	300	350
11	220	2893	220	100	300	380
12	240	2652	240	100	350	410
13	260	2448	260	100	350	440
14	280	2273	280	100	350	470
15	300	2122	300	100	400	500
16	320	1989	320	100	400	540
17	340	1872	340	100	400	580
18	360	1768	360	100	450	620
19	380	1675	380	100	450	660
20	400	1591	400	100	500	700
21	450	1414	400	90	600	800
22	500	1273	450	80	700	950
23	550	1157	450	70	800	1100
24	600	1061	500	60	900	1300
25	650	979	550	50	1000	1500
26	700	909	600	40	1100	1800
27	750	848	650	30	1200	2100
28	800	795	700	20	1300	2400
29	850	748	750	10	1400	2700
30	900	707	800	10	1500	3000

P0-04 Rigidity level	P1-00 Speed loop gain	P1-01 Speed loop integral	P1-02 Position loop gain	P2-35 Torque instruction filter	P2-49(3700~3720) Model loop gain	P2-49(3730 and above) Model loop gain
31	950	670	900	10	1500	3100
32	1000	636	900	10	1600	3200
33	1050	606	950	10	1800	3300
34	1100	578	1000	10	2000	3400
35	1150	553	1050	10	2200	3500
36	1200	530	1100	10	2400	3600
37	1250	509	1100	10	2500	3700
38	1300	489	1100	10	2600	3800
39	1350	471	1200	10	2700	3900
40	1400	454	1200	10	2800	4000
41	1450	439	1250	10	2900	4100
42	1500	424	1300	10	3000	4200
43	1550	410	1350	10	3200	4300
44	1600	397	1400	10	3500	4400
45	1650	385	1450	10	3800	4500
46	1700	374	1500	10	4000	4600
47	1750	363	1750	10	4500	4800
48	1800	353	1800	10	5000	5000
49	1850	344	1850	10	5000	5000
50	1900	335	1900	10	5000	5000
51	1950	326	1950	10	5000	5000
52	2000	318	2000	10	5000	5000
53	2050	310	2050	10	6000	6000
54	2100	303	2100	10	6000	6000
55	2150	296	2150	10	6000	6000
56	2200	289	2200	10	6000	6000
57	2250	282	2250	10	6000	6000
58	2300	276	2300	10	6000	6000
59	2350	270	2350	10	6000	6000
60	2400	265	2400	10	6000	6000
61	2450	259	2450	10	6000	6000
62	2500	254	2500	10	6000	6000
63	2600	244	2600	10	6000	6000

The rigidity level should be set according to the actual load. The larger the P0-04 value, the greater the servo gain. If there is vibration in the process of increasing the rigidity level, it is not suitable to continue to increase. If vibration suppression is used to eliminate vibration, it can try to continue to increase. The following is the recommended rigidity level of the load for reference.

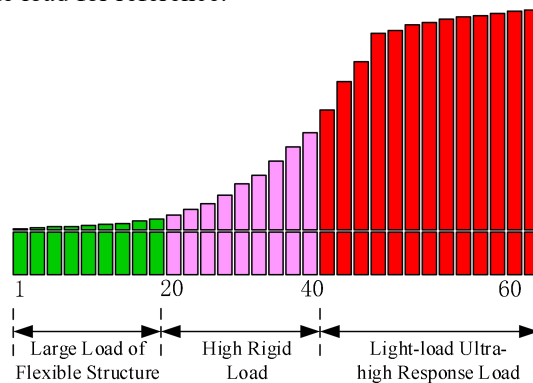

Flexible structure large load: refers to the type of synchronous belt structure, large load inertia equipment.

High rigid load: refers to the mechanism of screw rod or direct connection, and equipment with strong mechanical rigidity.

Ultra-high response load under light load: refers to equipment with very small inertia, strong mechanical stiffness and high response.

Driver Power	Default parameter	Rigidity level for firmware 3700 and above versions
1.5kw and above	P1-00=200 P1-01=3183 P1-02=200 P2-35=100 P2-49=300	10
100w~750w	P1-00=300 P1-01=2122 P1-02=300 P2-35=100 P2-49=400	15

9.3.4 Notes:

- ◆ The gain parameters corresponding to the rigidity level can be independently fine-tuned in the fast adjustment mode.
- ◆ In order to ensure stability, the gain of model loops is small at low rigidity level, which can be added separately when there is high response requirement.
- ◆ When vibration occurs in fast adjustment, the torque instruction filter P2-35 can be modified. If it is ineffective, the mechanical characteristic analysis can be used and the relevant notch parameters can be set (refer to chapter 6.7 vibration suppression).
- ◆ Fast adjustment mode defaults to set a rigidity level. If the gain does not meet the mechanical requirements, please gradually increase or decrease the settings.

9.4 Auto-tuning

9.4.1 Overview

Auto-tuning is divided into internal instruction auto-tuning and external instruction auto-tuning.

Auto-tuning (internal instruction) refers to the function of automatic operation (forward and reverse reciprocating motion) of servo unit without instructions from the upper device and adjusting according to the mechanical characteristics in operation.

Auto-tuning (external instruction) is the function of automatically optimizing the operation according to the instructions from the upper device.

The automatic adjustments are as follows:

- ◆ Load moment of inertia
- ◆ Gain parameters (speed loop, position loop, model loop gain)
- ◆ Filter (notch filter, torque instruction filter)

9.4.2 Notes

Untunable occasions

- ◆ Mechanical systems can only operate in one direction.

Setting the occasion prone to failure

- ◆ Excessive load moment of inertia
- ◆ The moment of inertia varies greatly during operation.
- ◆ Low mechanical rigidity, vibration during operation and failure of detection positioning.
- ◆ The running distance is less than 0.5 circles.

Preparations before auto-tuning

- ◆ Use position mode;
- ◆ Driver in bb status;
- ◆ Driver without alarm;
- ◆ The matching of the number of pulses per rotation and the width of positioning completion should be reasonable.

9.4.3 Operation tools

Internal instruction auto-tuning and external instruction auto-tuning can be executed by driver panel and XinJeServo software.

Auto-tuning mode	Operation tools	Limit item
Internal instruction auto-tuning	XinJeServo software	All the versions support
external instruction auto-tuning	Driver panel	Driver firmware needs 3700 and higher versions

Note: please check the driver firmware version through U2-07.

9.4.4 Internal instruction auto-tuning steps

Driver panel auto-tuning steps

1. The inertia identification is carried out, and the inertia estimation steps please refer to chapter 9.2.4.
2. Enter F0-09, panel display iat-;

3. Press ENTER, panel display iat--; servo is in enabled status right now;

4. Press INC or DEC, panel display is tune and flashing, enter auto-tuning status.



5. Driver will automatically send pulse instructions, if the auto-tuning is successful, the panel shows done and flashing.

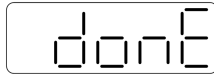

6. Press STA/ESC to exit internal instruction auto-tuning.

Note: In the process of auto-tuning, press STA/ESC will exit the auto-tuning operation and use the gain parameters at the exit time. If auto-tuning fails, it is necessary to initialize the driver before auto-tuning again.

■ Panel alarm in auto-tuning process

Error code	Meaning	Reasons
Err-1	Failure to search for optimal gain	Too large inertia ratio; too weak rigidity of mechanism
Err-2	Overtrip alarm in auto-tuning process	Please make sure that there is no overrun and alarm before auto-tuning.
Err-6	Driver is not in "bb" state at the time of operation	Please make sure the present status of driver.
Err-7	Driver alarmed in auto-tuning process	The driver alarm occurs.

XinJeServo software auto-tuning steps

1. Click auto-tuning on the XinJeServo software main interface.
2. Set the auto-tuning trip in jog mode or manually.

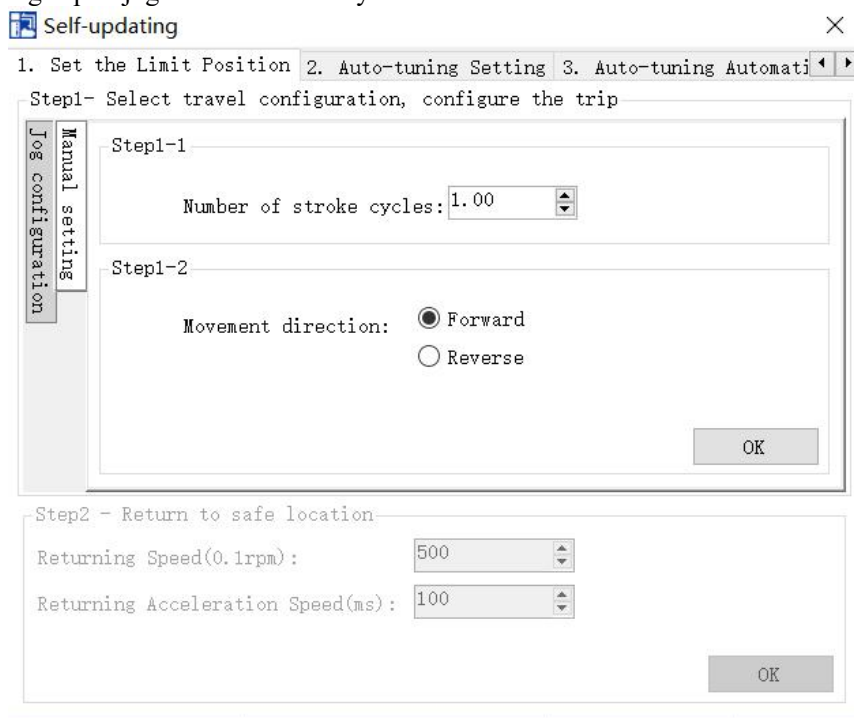

3. Set the auto-tuning interface

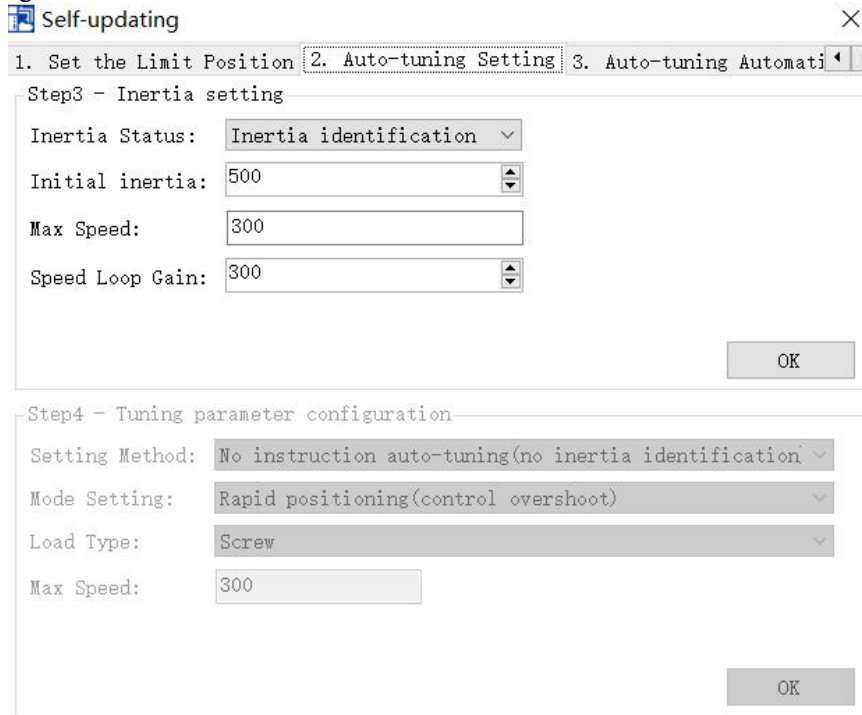

4. Click OK to estimate the inertia.

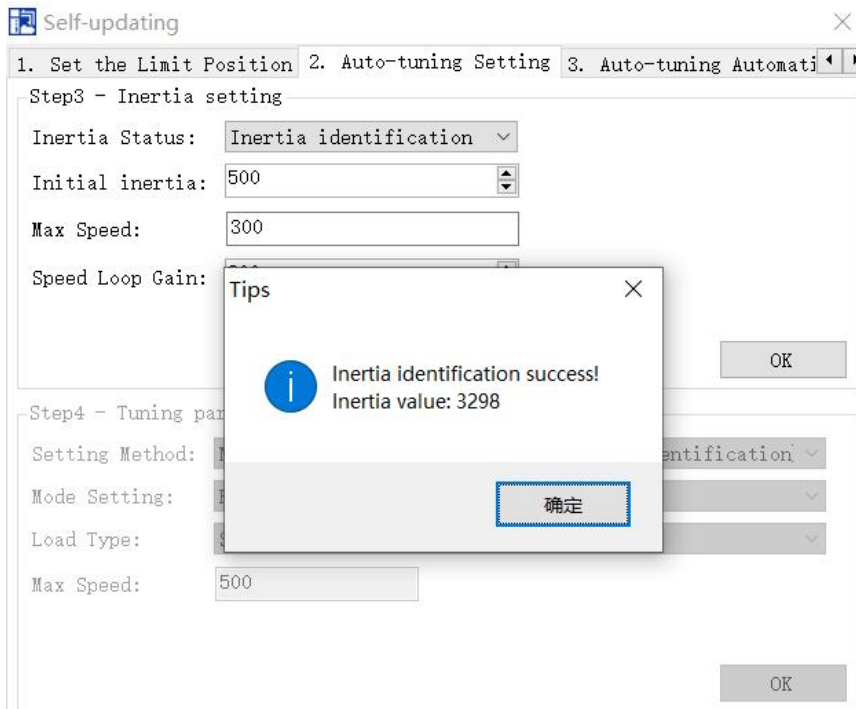

5. Set the auto-tuning parameters

The screenshot shows a software window titled 'Self-updating' with a close button (X) in the top right corner. The window has three tabs: '1. Set the Limit Position', '2. Auto-tuning Setting', and '3. Auto-tuning Automati'. The '2. Auto-tuning Setting' tab is active.

Step3 - Inertia setting

- Inertia Status:
- Initial inertia:
- Max Speed:
- Speed Loop Gain:

Step4 - Tuning parameter configuration

- Setting Method:
- Mode Setting:
- Load Type:
- Max Speed:

Both steps have an 'OK' button at the bottom right.

Auto-tuning mode	Description
Soft	Make a soft gain adjustment. Besides gain adjustment, notch filter is automatically adjusted.
Fast positioning	Make special adjustment for positioning purpose. Besides gain adjustment, the model loop gain and notch filter are automatically adjusted.
Fast positioning (control overshoot)	In the use of positioning, we should pay attention to adjusting without overshoot. Besides gain adjustment, the model loop gain and notch filter are automatically adjusted.

Load type	Description
Synchronous belt	Fit for the adjustment of lower rigidity mechanism such as synchronous belt mechanism.
Screw rod	It is suitable for adjustment of higher rigidity mechanism such as ball screw mechanism. If there is no corresponding mechanism, please choose this type.
Rigid connection	It is suitable for the adjustment of rigid body system and other mechanisms with higher rigidity.

6. Start auto-tuning

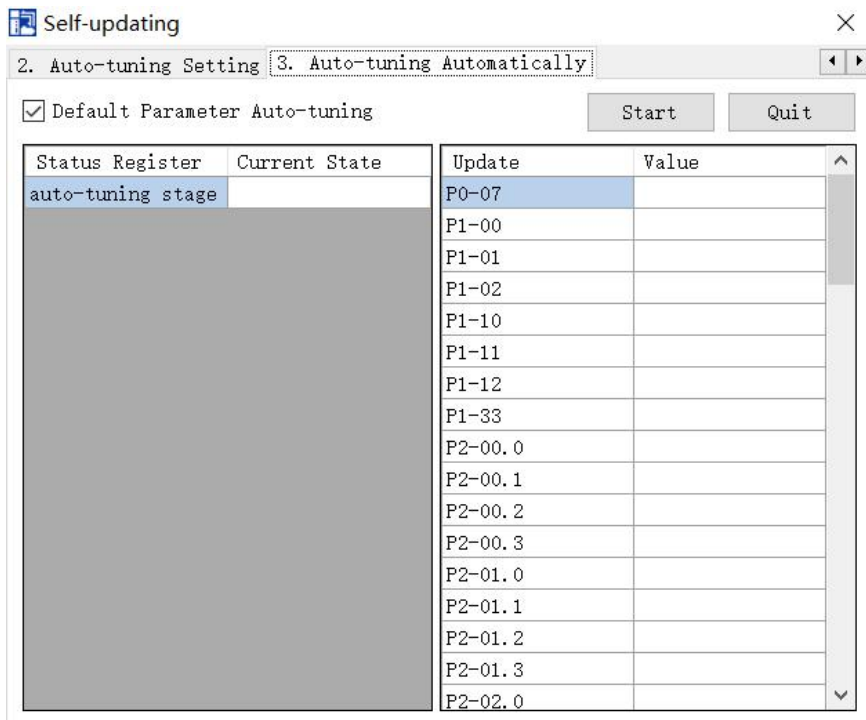

7. Wait for the end of the auto-tuning.

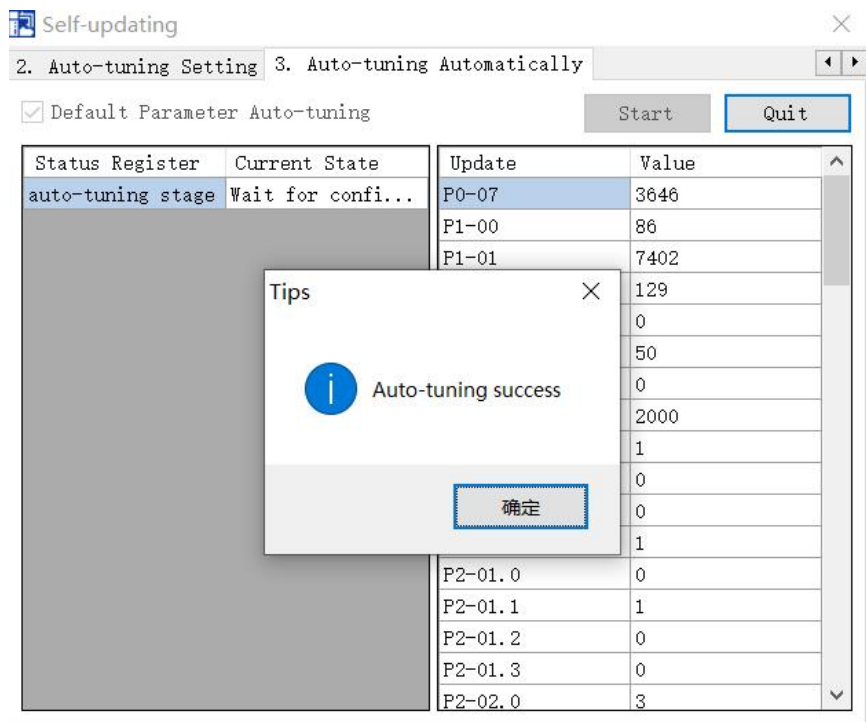

9.4.5 External instruction auto-tuning steps

Driver panel auto-tuning steps

The inertia identification is carried out and the step of inertia estimation please refers to the driver panel inertia estimation (9.2.4 Operation steps)

Enter parameter F0-08, it will show Eat- (External Reference Auto-tuning)

Eat-

Press ENTER, if the enable is not open, the panel displays Son and flickers, waiting for the enabler to open, if the enabler has been opened, skip this step;

Son

Servo enable, the panel displays tune and flickers, enter auto-tuning status.

tune

The upper device starts to send pulse, if the auto-tuning is successful, it displays done and flickers.

done

1. Press STA/ESC to exit the external instruction auto-tuning.

Note: in the auto-tuning process, press STA/ESC will exit the auto-tuning, and use the gain parameters at the exit moment.

■ Panel error alarm in auto-tuning process

Error code	Meaning	Reasons
Err-1	Failure to search for optimal gain	The inertia ratio is too large; Too weak rigidity of mechanism
Err-2	①Overrun/alarm occurs during auto-tuning ②External instruction auto-tuning/Vibration suppression mode: servo shut down the enabler during auto-tuning	Please make sure that there is no overrun and alarm before auto-tuning. Make sure that the enable is not closed during auto-tuning
Err-3	Current non-position control mode	Please auto-tune in position mode
Err-4	Unclosed adaptive function	Set P2-01.0 to 0 before auto-tuning
Err-7	Driver alarm during auto-tuning	Driver alarmed
Err-8	Positioning completion signal instability	Short instruction interval

XinJe Servo software auto-tuning steps

1. Click auto-tuning on the main interface of XinJeServo software

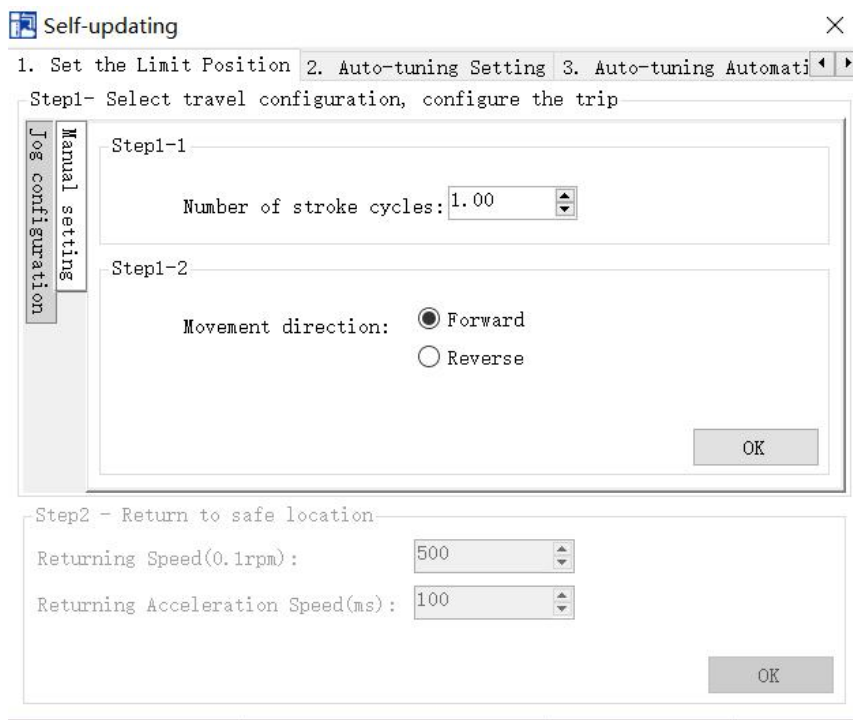

2. Select jog or manual setting to configure the trip of inertia identification.

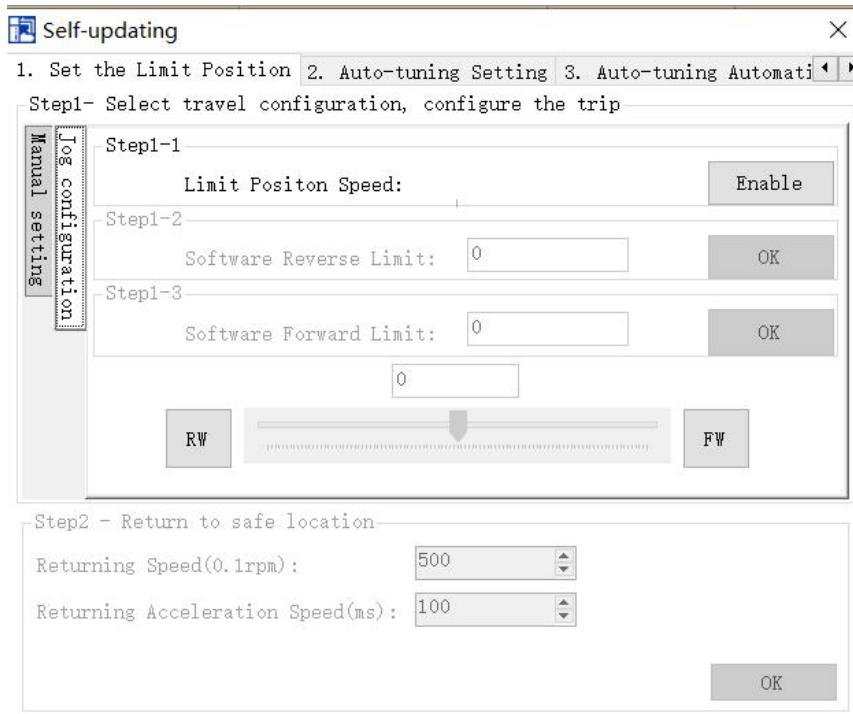

3. Set the auto-tuning interface

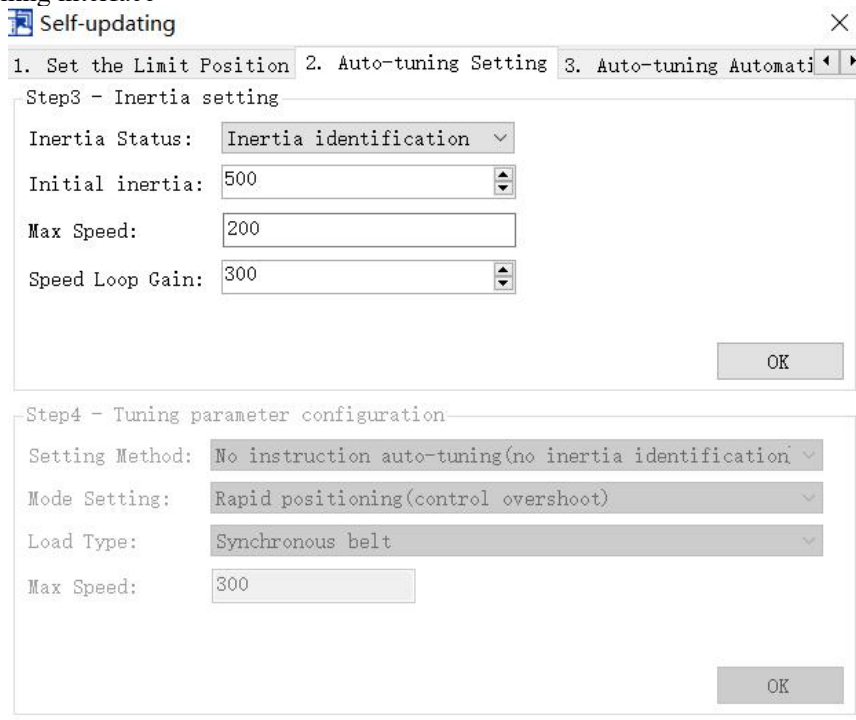

4. Click OK to start the inertia identification.

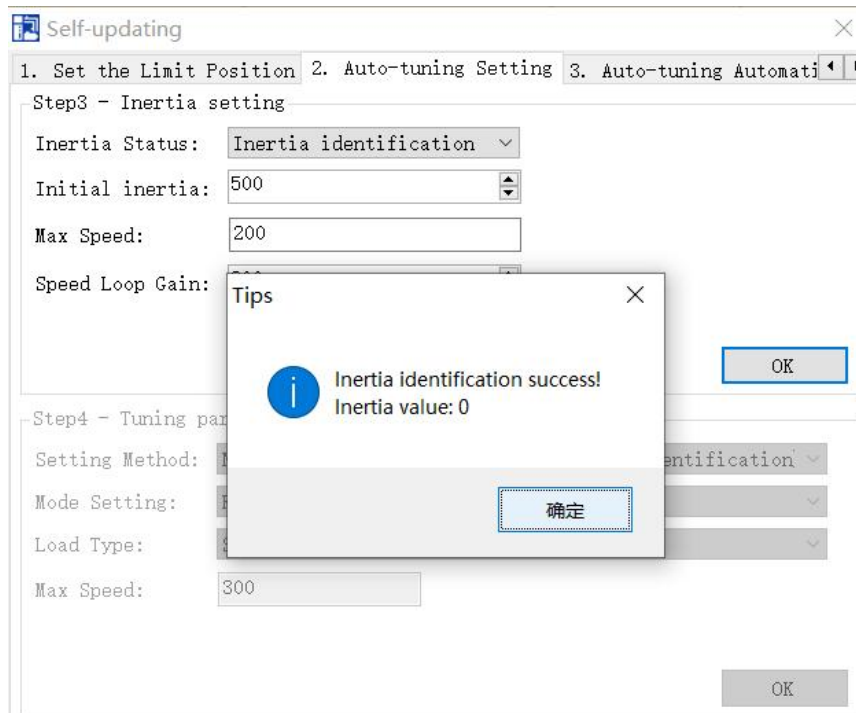

5. Configure the auto-tuning parameters

The screenshot shows a 'Self-updating' dialog box with three tabs: '1. Set the Limit Position', '2. Auto-tuning Setting', and '3. Auto-tuning Automati'. The '2. Auto-tuning Setting' tab is active, showing two sections:

Step3 - Inertia setting

- Inertia Status: Inertia identification (dropdown)
- Initial inertia: 500 (spin box)
- Max Speed: 200 (spin box)
- Speed Loop Gain: 300 (spin box)

Step4 - Tuning parameter configuration

- Setting Method: No instruction auto-tuning(no inertia identification) (dropdown)
- Mode Setting: Rapid positioning(control overshoot) (dropdown)
- Load Type: Synchronous belt (dropdown)
- Max Speed: 300 (spin box)

Both sections have an 'OK' button at the bottom right.

Auto-tuning mode	Description
Soft	Make a soft gain adjustment. Besides gain adjustment, notch filter is automatically adjusted.
Rapid positioning	Make special adjustment for positioning purpose. Besides gain adjustment, the model loop gain and notch filter are automatically adjusted.
Rapid positioning (control overshoot)	In the use of positioning, we should pay attention to adjusting without overshoot. Besides gain adjustment, the model loop gain and notch filter are automatically adjusted.

Load type	Description
Synchronous belt	Adjustment of lower rigidity mechanism such as synchronous belt.
Screw	It is suitable for adjusting higher rigidity mechanism such as ball screw mechanism. If there is no corresponding mechanism, please choose this type.
Rigid connection	It is suitable for the adjustment of rigid body system and other mechanisms with higher rigidity.

6. Start auto-tuning automatically

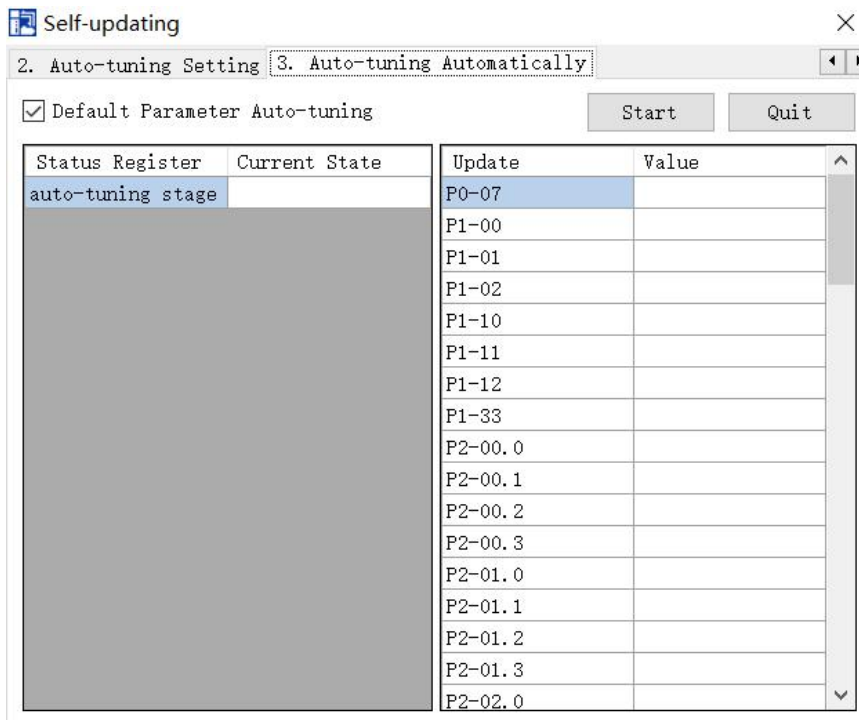

7. Auto-tuning is finished, click ok.

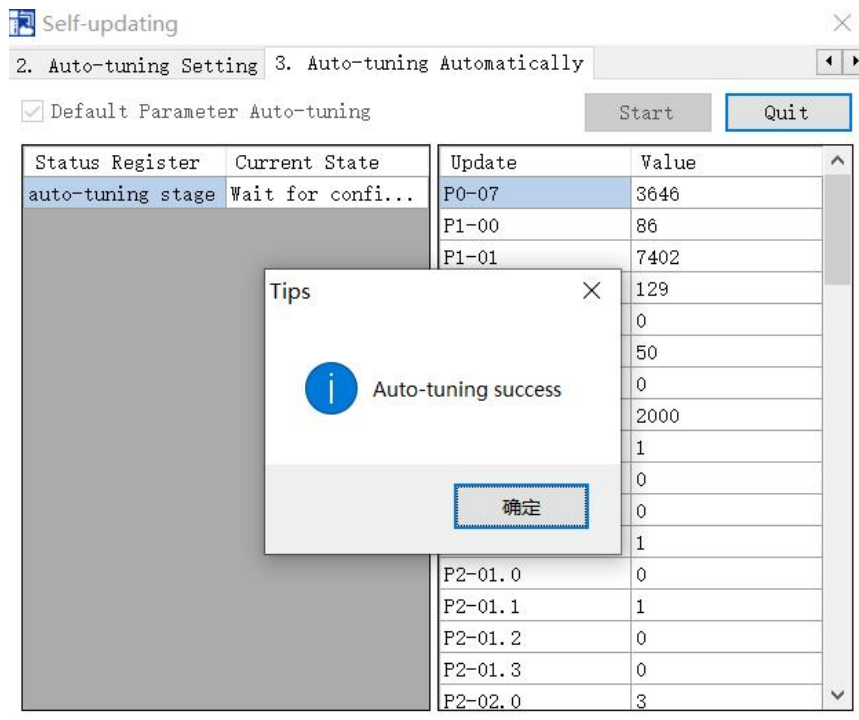

9.4.6 Related parameters

The following parameters may be modified during auto-tuning. Do not change them manually during auto-tuning.

Parameter	Name	Property	Effect of value on gain after setting
P0-07	First inertia ratio	Gain performance parameters	Yes
P1-00	First speed loop gain		
P1-01	Integral time constant of the first speed loop		
P1-02	First position loop gain		
P2-00.0	Disturbance observer switch		
P2-01.0	Adaptive mode switch		
P2-35	Torque command filter time constant 1		
P2-41	Disturbance observer gain		
P2-47.0	model loop switch		
P2-49	model loop gain		
P2-55	model speed feedforward gain		
P2-60.0	Active vibration suppression switch		
P2-61	Active vibration suppression frequency		
P2-62	Active vibration suppression gain		
P2-63	Active vibration suppression damping		
P2-64	Active vibration suppression filtering time 1		
P2-65	Active vibration suppression filter time 2		
P2-66	The second group of active vibration damping		
P2-67	The second group of active vibration suppression frequencies		
P2-69.0	First notch switch		
P2-69.1	Second notch switch		
P2-71	First notch frequency		
P2-72	First notch attenuation		
P2-73	First notch band width		
P2-74	Second notch frequency		
P2-75	Second notch attenuation		
P2-76	Second notch band width		
P2-17	Inertia identification and internal instruction auto-tuning max speed	Auto-tuning setting parameters	No
P2-86	auto-tuning jog mode		
P2-87	auto-tuning min limit position		
P2-88	auto-tuning max limit position		
P2-89	auto-tuning max speed		
P2-90	auto-tuning acceleration/deceleration time		

Note: P2-60~P2-63 are automatically modified in auto-tuning process. Users are not allowed to modify them manually. Manual modification may lead to the risk of system runaway.

9.5 Manual adjustment

9.5.1 Overview

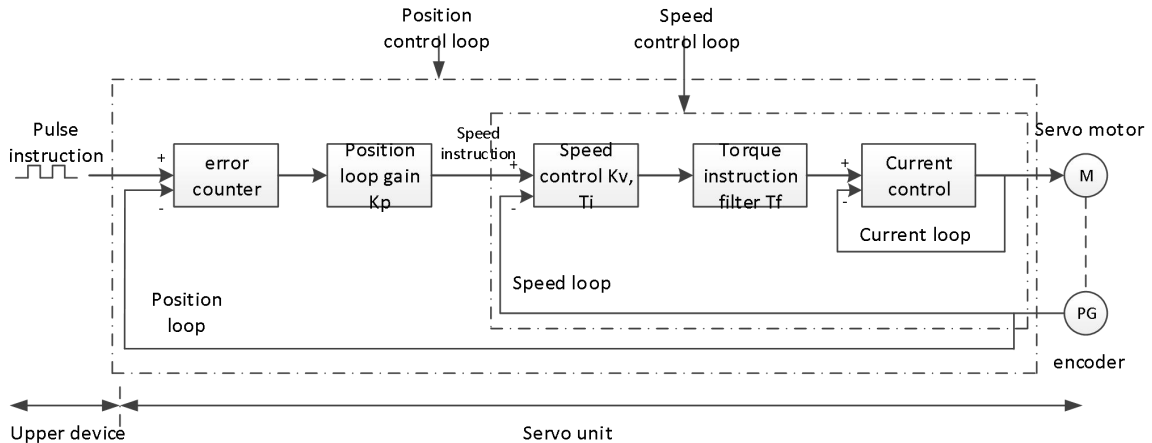

Position control loop diagram (shut down the model loop)

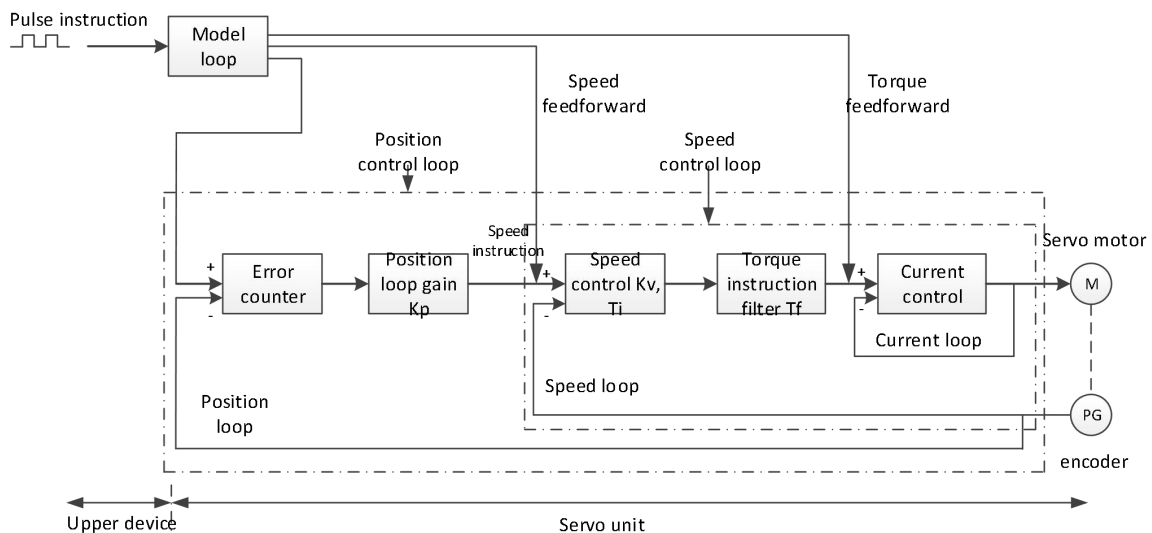

Position control loop diagram (turn on the model loop)

Servo unit consists of three feedback loops (current loop, speed loop and position loop) from inside to outside. The more inner loop, the more responsive it is. Failure to comply with this principle will result in poor response or vibration. Among them, the current loop parameters are fixed values to ensure adequate responsiveness, and users do not need to adjust.

Please use manual adjustment in the following occasions:

- When the expected effect can not be achieved by fast adjusting the gain
- When the expected effect is not achieved by automatically adjusting the gain

9.5.2 Adjustment steps

In position mode, if the soft mode (P2-02.0=1) is selected by auto-tuning, the function of model loop will be turned off; in speed mode, the gain of position loop will be invalid.

Increasing response time

1. Reducing the filter time constant of torque instruction (P2-35)
2. Increasing Speed Loop Gain (P1-00)
3. Reducing Integral Time Parameter of Speed Loop (P1-01)
4. Increasing the gain of position loop (P1-02)

5. Improving Model Loop Gain (P2-49)

Reduce response, prevent vibration and overshoot

1. Reduce the Speed Loop Gain (P1-00)
2. Increase Integral Time Constant of Speed Loop (P1-01)
3. Reduce the gain of position loop (P1-02)
4. Increase the filter time constant of the torque instruction (P2-35)
5. Reduce Model Loop Gain (P2-49)

9.5.3 Gain parameter for adjustment

The gain parameters that need to be adjusted:

- P1-00 Speed loop gain
- P1-01 Integral Time Constant of Speed Loop
- P1-02 Position loop gain
- P2-35 Torque instruction filter time constant
- P2-49 Model loop gain

■ Speed loop gain

Because the response of the speed loop is low, it will become the delay factor of the outer position loop, so overshoot or vibration of the speed command will occur. Therefore, in the range of no vibration of mechanical system, the larger the setting value, the more stable the servo system and the better the responsiveness.

Parameter	Name	Default setting	Unit	Range	Modification	Effective
P1-00	Speed loop gain	≤ 20 P7:300 ≥ 21 P0:200	0.1Hz	10~20000	Anytime	At once

■ Speed loop integration time constant

In order to respond to small inputs, the speed loop contains integral elements. Because this integral element is a delay element for the servo system, when the time constant is set too large, overshoot will occur, or the positioning time will be prolonged, resulting in poor responsiveness.

The gain of the speed loop and the integral time constant of the speed loop roughly meet the following relationship: $P1-00 \times P1-01 = 636620$.

Parameter	Name	Default setting	Unit	Range	Modify	Effective
P1-01	Speed loop integration time constant	≤ 20 P7:2122 ≥ 21 P0:3183	0.01ms	15~51200	Anytime	At once

■ Position loop gain

When the model loop is invalid ($P2-47.0=0$), the responsiveness of the position loop of the servo unit is determined by the gain of the position loop. The higher the position loop gain is, the higher the responsiveness is and the shorter the positioning time is. Generally speaking, the gain of position loop cannot be increased beyond the natural vibration number of mechanical system. Therefore, in order to set the position loop gain to a larger value, it is necessary to improve the rigidity of the machine and increase the number of inherent vibration of the machine.

Parameter	Meaning	Default setting	Unit	Range	Modify	Effective
P1-02	Position loop gain	≤ 20 P7:30 0 ≥ 21 P0:20 0	0.1/s	10~20000	Anytime	At once

■ Torque command filtering time constant

When machine vibration may be caused by servo drive, it is possible to eliminate vibration by adjusting the filtering time parameters of the following torque instructions. The smaller the numerical value, the better the response control can be, but it is restricted by the machine conditions. When vibration occurs, the parameter is

generally reduced, and the adjustment range is suggested to be 10-150.

Parameter	Name	Default setting	Unit	Range	Modify	Effective
P2-35	Torque command filtering time constant	100	0.01ms	0~65535	Anytime	At once

■ **Model loop gain**

When the model loop is valid (P2-47.0=1), the response of the servo system is determined by the gain of the model loop. If the gain of the model loop is increased, the responsiveness is increased and the positioning time is shortened. At this time, the response of the servo system depends on this parameter, not P1-02 (position loop gain). The gain of the model loop is only valid in position mode.

Parameter	Meaning	Default setting	Unit	Range	Modify	Effective
P2-49	Model loop gain	<=20P7:500 >=21P0:350	0.1Hz	10~20000	Anytime	At once

9.6 Adaptive

9.6.1 Overview

Adaptive function means that no matter what kind of machine and load fluctuation, it can obtain stable response through automatic adjustment. It starts to automatically adjust when servo is ON.

9.6.2 Notes

- ◆ When the servo unit is installed on the machine, it may produce instantaneous sound when the servo is ON. This is the sound when the automatic notch filter is set, not the fault. For the next time the servo is ON, no sound will be emitted.
- ◆ When the inertia of the motor exceeds the allowable load, the motor may produce vibration. At this time, please modify the adaptive parameters to match the present load inertia.
- ◆ In adaptive operation, in order to ensure safety, the adaptive function should be executed at any time when the servo enablement can be stopped or turned off urgently.

9.6.3 Operation steps

The factory settings are self-adaptive effective without modifying other parameters. The effectiveness of self-adaptation is controlled by the following parameters.

Parameter		Meaning	Default setting	Modify	Effective
P2-01	n.□□□0	Adaptive shutdown	n.□□□1	Servo bb	Re-power on
	n.□□□1	Adaptive open			

9.6.4 Inertia mode and related parameters

The adaptive default parameter is defined as small inertia mode. If the load inertia far exceeds the allowable load inertia of the motor (such as 60 times inertia of the 60 motor), the adaptive large inertia mode can be turned on.

Parameter		Meaning	Default setting	Modify	Effective
P2-03	n.0□□□	Adaptive small inertia mode	n.0□□□	Servo bb	Re-power on
	n.1□□□	Adaptive large inertia mode			

Parameter	Meaning	Default setting	Modify	Effective
P2-05	Adaptive speed loop gain	400 ^{Note 1}	Servo bb	Re-power on
P2-10	Adaptive speed loop integral	500	Servo bb	Re-power on
P2-11	Adaptive position loop gain	100	Servo bb	Re-power on
P2-07	Adaptive inertia ratio	0	Servo bb	Re-power on
P2-08	Adaptive speed observer gain	60	Servo bb	Re-power on
P2-12	Adaptive stable max inertia ratio	30	Servo bb	Re-power on
P2-16	Adaptive motor rotor inertia coefficient	100	Servo bb	Re-power on
P2-19	Adaptive bandwidth	50 ^{Note 2}	Anytime	At once
P6-05	Adaptive large inertia mode speed loop gain	200	Servo bb	Re-power on
P6-07	Adaptive large inertia mode inertia ratio	50	Servo bb	Re-power on
P6-08	Adaptive large inertia mode speed observer gain	40	Servo bb	Re-power on
P6-12	Adaptive large inertia mode max inertia ratio	50	Servo bb	Re-power on

Note 1: The default value of 750W and below DS5series servo is 400. The default value of other power is 200.

Note 2: The default value of 400W and below DS5 series servo drivers is 70; The default value of other power is 50.

9.6.5 Recommended inertia ratio parameters

Under the adaptive default parameters, the load can only run steadily under a certain moment of inertia. If the load inertia is large, some parameters need to be adjusted. The recommended parameters are as follows (the parameters are modified under the default parameters).

Motor flange	Inertia	Parameter
40~90 flange	Within 20 times inertia	Adaptive small inertia mode(default parameters)
	20~30 times inertia	Set P2-08=50, P2-12=40
	30~40 times inertia	Set P2-08=50, P2-12=40, P2-07=10
	40~50 times inertia	Set P2-08=50, P2-12=40, P2-07=30
	50~80 times inertia	Switch to adaptive large inertia mode or set P2-08=40,P2-12=50,P2-07=50
110, 130 flange	Within 10 times inertia	Adaptive small inertia mode (default parameters)
	10~15 times inertia	Set P2-08=50, P2-12=40
	15~20 times inertia	Switch to adaptive large inertia mode or set P2-08=40, P2-12=50, P2-07=50
180 and above flange	Within 5 times inertia	Adaptive small inertia mode (default parameters)
	5~10 times inertia	Set P2-08=50, P2-12=40
	10~20 times inertia	Switch to adaptive large inertia mode or set P2-08=40, P2-12=50, P2-07=50

Note: The large inertia parameters can still drive a smaller inertia load. For example, when the parameters of 50 times inertia are used in the mechanism of 20 times inertia, only the response will become worse.

9.6.6 Adaptive parameter effect

Parameter small /large inertia	Name	Default value	Range	Effect
P2-05/P6-05	Adaptive speed loop gain	400/200	200~400	Decreasing can improve the inertia capacity, but will reduce the responsiveness, which has a great impact on the responsiveness
P2-07/P6-07	Adaptive load inertia ratio	0/50	0~200	Increase can greatly improve the inertia capacity, and will not affect the responsiveness. Too large will cause oscillation
P2-08/P6-08	Speed observer gain	60/40	30~60	Decreasing P2-08 and increasing P2-12 can greatly improve the inertia capability, but will reduce the responsiveness, which has a great impact on the responsiveness
P2-12/P6-12	Adaptive stable max inertia ratio	30/50	30~60	
P2-10	Adaptive speed loop integral time coefficient	500	200~larger	Adjust according to need, generally increase
P2-11	Adaptive position loop gain coefficient	100	50~200	Adjust according to the need, increasing will make the response fast, reducing will make the response slow
P2-16	Adaptive motor rotor inertia coefficient	100	100~200	Increasing can improve the servo rigidity, enhance the anti-interference ability, and solve the running jitter
P2-19	Adaptive bandwidth	50~70	40~80	Increasing will slightly improve the inertia capacity of the belt, which has little impact on the responsiveness, as an auxiliary parameter

9.6.7 Invalid parameters when adaptive effective

When the adaptive function is effective (P2-01.0=1), the invalid parameters are shown as below:

Item	Parameters	Name
Gain	P1-00	First speed loop gain
	P1-05	Second speed loop gain
	P1-01	First speed loop integral time constant
	P1-06	Second speed loop integral time constant
	P1-02	First position loop gain
	P1-07	Second position loop gain
	P2-49	Model loop gain
	P0-07	First inertia ratio
	P0-08	Second inertia ratio
	P5-36	/I-SEL inertia ratio switch

9.7 Vibration suppression

9.7.1 Overview

The mechanical system has a certain resonance frequency. When the servo gain is increased, the continuous vibration may occur near the resonance frequency of the mechanical system. Generally in the range of 400Hz to 1000Hz, it caused the gain can not continue to increase. Vibration can be eliminated by automatically detecting or manually setting the vibration frequency. After the vibration is eliminated, if the responsiveness needs to be improved, the gain can be further improved.

Note:

- (1) Servo responsiveness will change after vibration suppression operation.
- (2) Please set the inertia ratio and gain parameters correctly before performing the vibration suppression operation, otherwise it can not be controlled properly.

9.7.2 Operation tools

Adjustment mode	Operation tools	Control mode	Operation steps	Limitation
Adaptive mode	XinJeServo Mechanical Characteristic Analysis	Position mode	9.7.3 Vibration Suppression (PC Software)	All software versions support
Auto-tuning mode	Panel vibration suppression		9.7.3 Vibration Suppression (Panel)	3700 and above driver firmware version
	XinJeServo Mechanical Characteristic Analysis		9.7.4 Vibration Suppression (PC Software)	All software versions support
Auto-tuning /adaptive mode	Panel vibration suppression		9.7.5 Vibration suppression (easyFFT)	3730 and above driver firmware version

Note: The firmware version of the drive is viewed through U2-07.

9.7.3 Vibration suppression (panel)

There are two modes of panel vibration suppression, mode 1(vib-1) and mode 2(vib-2).

■ Difference between Two Kinds of Vibration Suppression

Mode	Display	Changed parameters
Mode 1	vib-1	Only the parameters related to vibration suppression will be changed.
Mode 2	Vib-2	It will change the parameters of vibration suppression and the gain of speed loop.

The operation steps:

1. Enter F0-10 in auto-tuning mode, the panel shows vib-1 or enter F0-11, the panel shows vib-2;

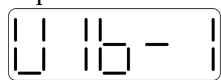
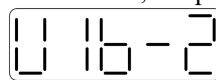
 or
 

2. Press ENTER, panel shows Son and flashes, turn on the enabler by manual;

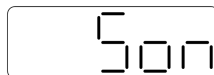

3. After turn on the enabler, panel shows tune and flickers, enter auto-tuning process;

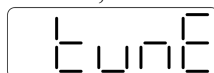

4. The upper device starts to send pulses, then it will show done and flicker

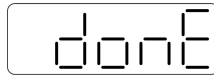

5. Press STA/ESC to exit.

6. Vibration suppression parameters are automatically written into the second and first notches (the second notches are preferred when there is only one vibration point). The related parameters are detailed in 9.7.7 notch filter.

■ Fault alarm of panel in vibration suppression process

Error code	Meaning	Reasons
Err-1	Failure to search for optimal gain	The inertia ratio is too large; Too weak rigidity of mechanism
Err-2	① Overtravel/alarm occurs during self-tuning ② External command tuning/vibration suppression mode: servo off enable during tuning	Please make sure that there is no overtravel and alarm before self-tuning Please make sure that the setting process is not disabled
Err-3	Non-position control mode	Please auto-tune in position mode
Err-4	Not turn off the adaptive function	Please modify P2-01.0 to 0 before self tuning
Err-7	Driver alarm in auto-tuning process	Drive alarm
Err-8	Positioning Completion Signal Instability	Command interval time is too short

9.7.4 Vibration suppression (PC software)

1. Open XinJeServo software, click mechanical properties.
2. Click measure

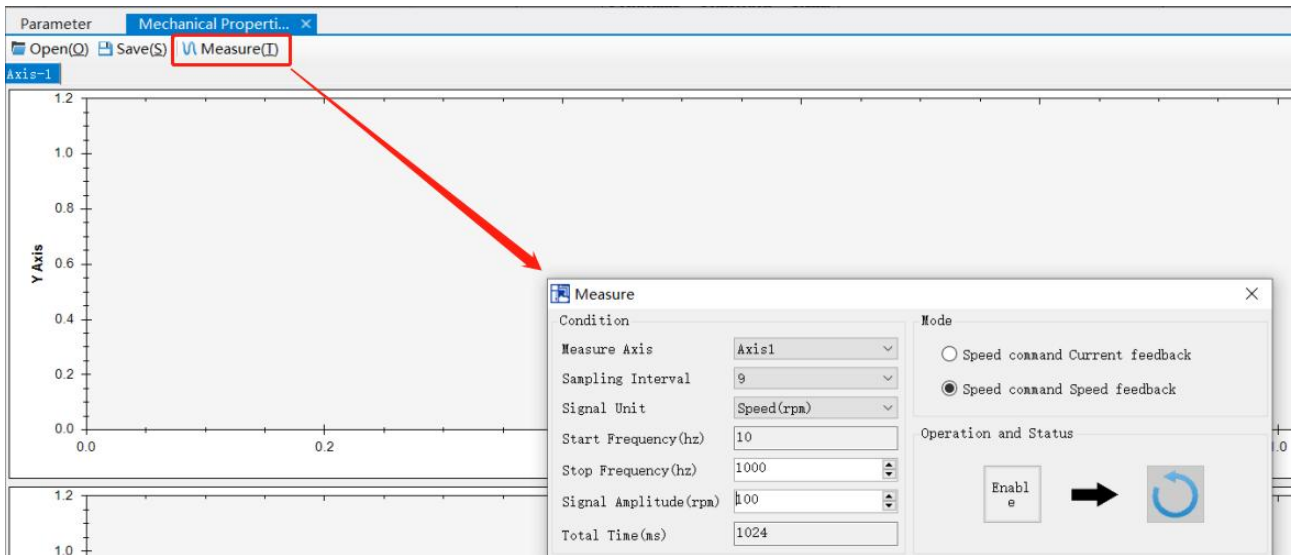

3. Set the measure conditions, then click execute;

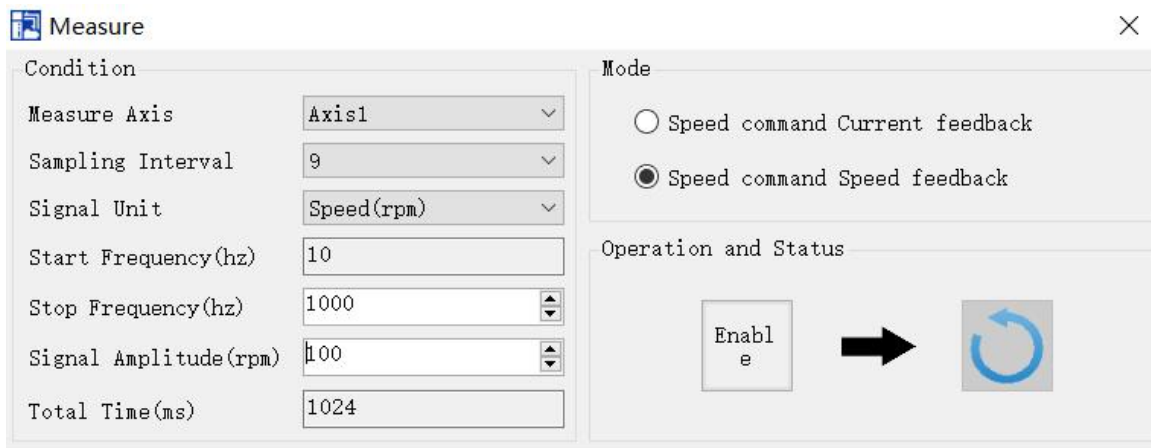

4. Select amplitude and phase;

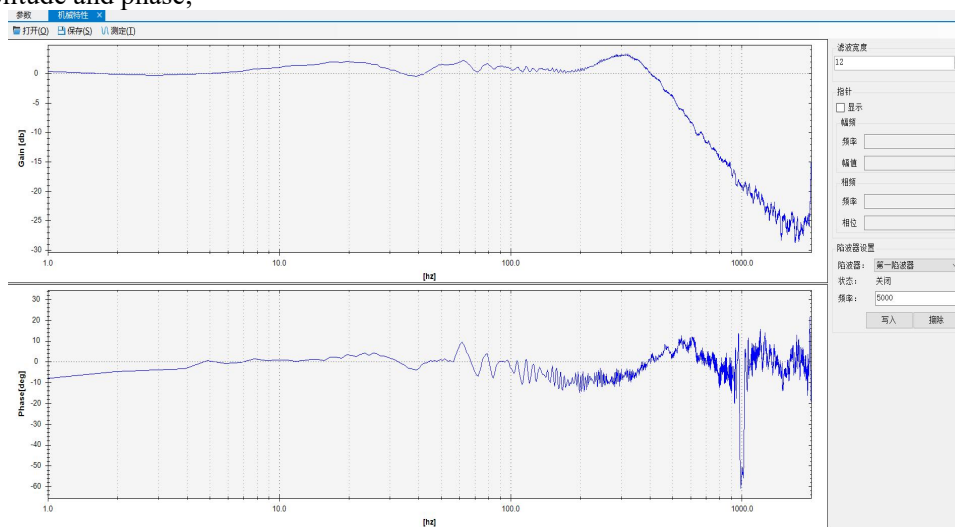

5. Set the filter width (to see resonance frequencies clearly), find the resonance frequency;
6. Notch parameters need to be set manually. Refer to [9.7.7 notch filter](#) for details.

As an example, through the analysis of mechanical characteristics, the resonance frequency is 328 Hz, and the third notch filter can be used. The parameters are as follows:
 $P2-69 = n.1000$, $P2-77 = 328$

Note: In both adaptive and auto-tuning modes, if mechanical characteristic analysis is used, the notch can be set manually. If there are multiple resonance points, the third to fifth notch can be configured in turn.

9.7.5 Vibration suppression(manual setting)

If the resonance frequency of the mechanical system is known, the vibration can be eliminated by setting the vibration frequency manually. Please configure the third to fifth notches. The related parameters are detailed in [9.7.7 notch filter](#).

9.7.6 Vibration suppression(easy FFT)

The function can analyze the mechanical characteristics through the parameter F0-12 on the servo operate panel, find out the mechanical resonance frequency and realize the vibration suppression. The complete operation process is shown in the figure below:

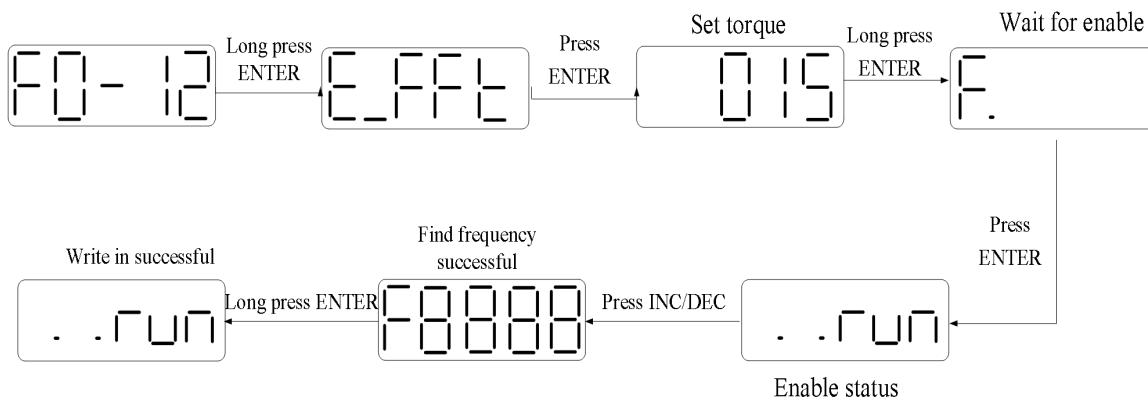

The operation steps are described as follows:

1. F0-12, long press **【ENTER】** to enter quick FFT function, it will show “E_FFt”.

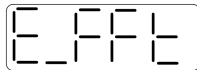

2. Press **【ENTER】** to enter torque setting interface, it will show the current setting torque, which is the value of P6-89. Press **【INC】**, **【DEC】** to increase or decrease torque command. When increasing the torque command, it is recommended to increase it a little bit to avoid severe vibration of the equipment.

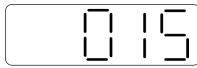

3. After setting the torque command, long press **【ENTER】**, enter “read to enable” status, it will show ‘F’.



4. Press **【ENTER】**, enable, it will show “..run”.

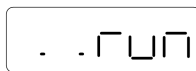

5. Press **【INC】**, **【DEC】** to run forward or reverse and find the resonance frequency. “E_FFt” will shining on the panel when operation. If the resonance frequency is found, it will show “Fxxxx”, “xxxx” is the resonance frequency. If failed, it will show “F----”.

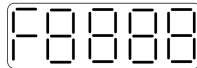

6. Whatever it shown “Fxxxx” or “F----”, press **【INC】**, **【DEC】** can find the resonance frequency again. If the resonance frequency is found, long press **【ENTER】** to set the resonance frequency in the notch filter of servo driver.

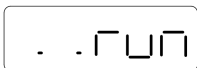

Note: for above each step, press STA/ESC can return to the last step or exit.

9.7.7 Notch filter

Notch filter can suppress mechanical resonance by reducing the gain at a specific frequency. After the notch filter is set correctly, the vibration can be effectively suppressed and the servo gain can be continuously increased. The principle diagram of notch filter is as follows:

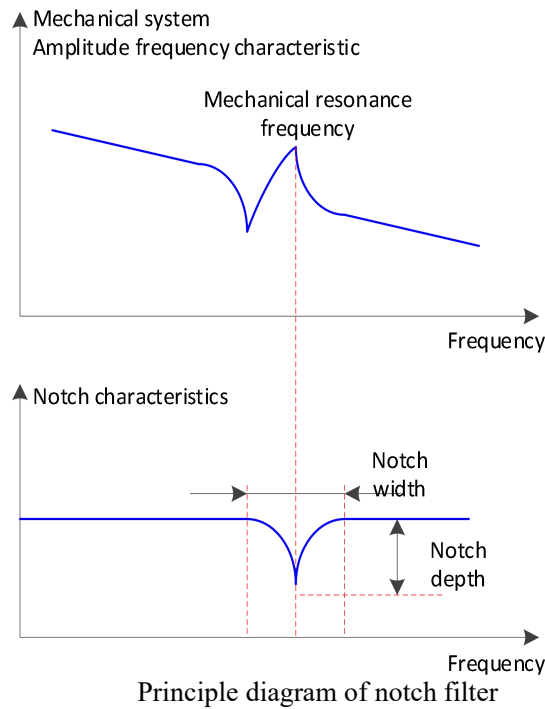

The servo driver has five sets of notch filters, each with three parameters, notch frequency, notch attenuation and notch bandwidth. The first and second notches are set automatically, and the third, fourth and fifth are set manually.

The torque instruction filter and notch filter are in series in the system. As shown in the figure below, the switch of the notch filter is controlled by P2-69 and P2-70.

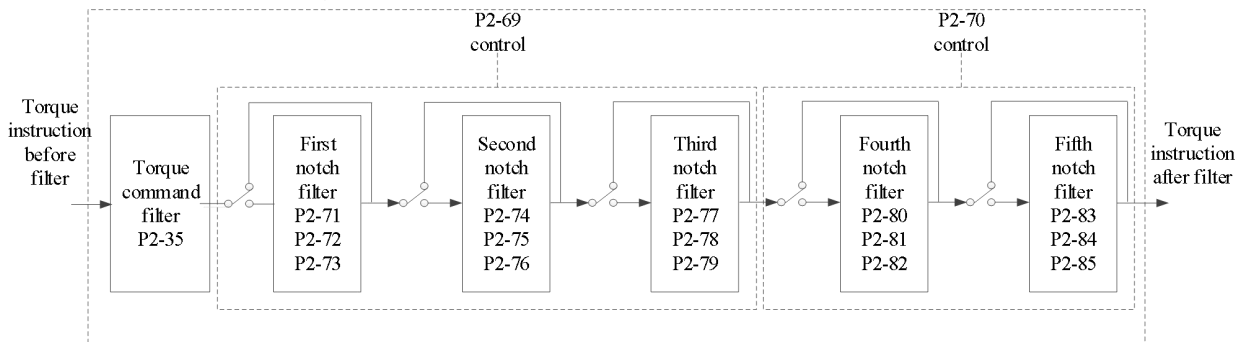

Parameter	Meaning	Default setting	Modify	Effective	
P2-69	n.□□□0	First notch off	n.□□□0	Anytime	At once
	n.□□□1	First notch on			
	n.□□0□	Second notch off	n.□□0□	Anytime	At once
	n.□□1□	Second notch on			
	n.0□□□	Third notch off	n.0□□□	Anytime	At once
	n.1□□□	Third notch on			
P2-70	n.□□□0	Fourth notch off	n.□□□0	Anytime	At once
	n.□□□1	Fourth notch on			

	n.□□0□	Fifth notch off	n.□□0□	Anytime	At once
	n.□□1□	Fifth notch on			

Parameter	Meaning	Default setting	Unit	Range	Modify	Effective
P2-71	First notch frequency	5000	Hz	50~5000	Anytime	At once
P2-72	First notch attenuation	70	0.1dB	50~1000	Anytime	At once
P2-73	First notch bandwidth	0	Hz	0~1000	Anytime	At once
P2-74	Second notch frequency	5000	Hz	50~5000	Anytime	At once
P2-75	Second notch attenuation	70	0.1dB	50~1000	Anytime	At once
P2-76	Second notch bandwidth	0	Hz	0~1000	Anytime	At once
P2-77	Third notch frequency	5000	Hz	50~5000	Anytime	At once
P2-78	Third notch attenuation	70	0.1dB	50~1000	Anytime	At once
P2-79	Third notch bandwidth	0	Hz	0~1000	Anytime	At once
P2-80	Fourth notch frequency	5000	Hz	50~5000	Anytime	At once
P2-81	Fourth notch attenuation	70	0.1dB	50~1000	Anytime	At once
P2-82	Fourth notch bandwidth	0	Hz	0~1000	Anytime	At once
P2-83	Fifth notch frequency	5000	Hz	50~5000	Anytime	At once
P2-84	Fifth notch attenuation	70	0.1dB	50~1000	Anytime	At once
P2-85	Fifth notch bandwidth	0	Hz	0~1000	Anytime	At once

Note:

1. In the adaptive mode, if the vibration is detected, the second notch filter will be automatically configured.
2. In the auto-tuning mode, the second and first notches will be automatically configured if the vibration is detected (the second notches will be preferentially opened when there is only one vibration point).
3. Whether in self-adaptive or auto-tuning mode, if the mechanical characteristic analysis is sued, it belongs to manual setting of notches, please configure the third to fifth notches.

9.8 Gain adjustment application

9.8.1 Model loop control

In the self-tuning mode, in addition to the gain of speed loop and position loop, there is also the gain of model loop, which has a great influence on the servo response. When the model loop is not open, the servo responsiveness is determined by the position loop gain. When the model ring is open, the servo responsiveness is determined by the model loop gain. The model loop is equivalent to the feedforward function in the driver control loop. Refer to [9.5 Manual adjustment](#) for its specific function.

When the self-tuning mode is soft, the model loop function will be automatically off. When the self-tuning mode selects fast positioning or fast positioning (control overshoot), the model loop function will be automatically turned on.

Self-tuning mode

Parameter	Meaning	Default setting	Modify	Effective	
P2-02	n.□□□1	Soft	n.□□□3	Anytime	At once
	n.□□□2	Fast positioning			
	n.□□□3	Quick positioning (control overshoot)			

Selection of self-tuning mode:

(1) Soft(P2-02.0=1)

This mode does not turn on the gain of the model loop, and the operation is soft. It is suitable for

occasions with insufficient mechanical rigidity and low response requirements.

(2) Quick positioning (P2-02.0 = 2)

This method has the fastest response to setting parameters, but has no special suppression on overshoot.

(3) Quick positioning (control overshoot) (P2-02.0 = 3):

In this way, the setting parameter response is fast, which will inhibit the overshoot.

Load type	Explanation
Synchronous belt	The adjustment is suitable for the mechanism with lower rigidity such as synchronous belt mechanism.
Lead screw	It is suitable for the adjustment of high rigidity mechanism such as ball screw mechanism. Please select this type when there is no corresponding structure.
Rigid connection	The adjustment is suitable for rigid body system and other mechanisms with high rigidity.

Self-tuning mode	Explanation
Soft	Soft gain adjustment. In addition to gain adjustment, the notch filter is also adjusted automatically.
Fast positioning	Make special adjustment for positioning purpose. In addition to gain adjustment, the model loop gain and notch filter are also adjusted automatically
Fast positioning (control overshoot)	Pay attention to the adjustment of no overshoot in the positioning purpose. In addition to gain adjustment, the model loop gain and notch filter are also adjusted automatically.

Parameter	Meaning	Default setting	Modify	Effective	
P2-02	n.□□□1	Soft	n.□□□3	Anytime	At once
	n.□□□2	Fast positioning			
	n.□□□3	Fast positioning(control overshoot)			

Model loop function

Parameter	Meaning	Default setting	Modify	Effective	
P2-47	n.□□□0	Model loop turn off	n.□□□0	Anytime	At once
	n.□□□1	Model loop turn on			

Taking DS5 series servo auto-tuning mode and using 750W servo 5 times load inertia as an example:

■ Model loop function turns off (soft mode)

Low rigidity and low response	High rigidity and medium response
Load inertia ratio P0-07:500%	
Speed loop gain P1-00:200	Speed loop gain P1-00:800
Speed loop integral P1-01:3300	Speed loop integral P1-01:825
Position loop gain P1-02:200	Position loop gain P1-02:700
Phenomenon: Running jitter, slow response	Phenomenon: smooth operation and fast response

■ Model loop function turns on (fast positioning or fast position(control overshoot))

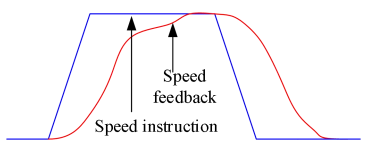
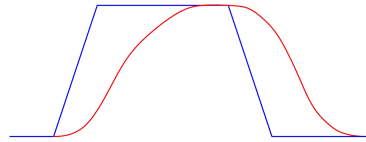
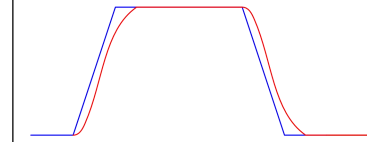
Low rigidity and low response	High rigidity and low response	High rigidity and high response
		
Load inertia ratio P0-07:500%		
Speed loop gain P1-00:200	Speed loop gain P1-00:800	Speed loop gain P1-00:800
Speed loop integral P1-01:3300	Speed loop integral P1-01:825	Speed loop integral P1-01:825
Position loop gain P1-02:200	Position loop gain P1-02:700	Position loop gain P1-02:700
Model loop gain P2-49:300	Model loop gain P2-49:300	Model loop gain P2-49:4000
Phenomenon: Running jitter, slow response	Phenomenon: smooth operation and slow response	Phenomenon: smooth operation And fast response

Note: The above curves only show the effect of the parameters, not the real running curves.

9.8.2 Torque disturbance observation

Disturbance observer can reduce the influence of external disturbance on servo system and improve the anti-disturbance ability by detecting and estimating the external disturbance torque of the system and compensating the torque command.

If the soft mode is selected in the auto-tuning mode, the disturbance observer will be closed automatically, and the gain of the disturbance observer will not change. If the fast positioning or fast positioning (control overshoot) is selected, the disturbance observer will be opened automatically, and the gain of the disturbance observer will be modified to 85. The relevant parameters of this function no need to be set manually by users.

Parameter		Meaning	Default setting	Modify	Effective
P2-00	n.□□□0	Turn off disturbance observer	n.□□□0	Servo bb	At once
	n.□□□1	Turn on disturbance observer			

Parameter	Meaning	Default setting	Unit	Setting range	Modify	Effective
P2-41	Disturbance observer gain	85	%	0~100	Anytime	At once

9.8.3 Gain adjust parameters

Parameter	Meaning	Default setting	Unit	Setting range	Modify	Effective
P1-00	First speed loop gain	<=20P7:300 >=21P0:200	0.1Hz	10~20000	Servo bb	At once
P1-01	Integral time constant of the first velocity loop	<=20P7:2122 >=21P0:3183	0.01ms	15~51200	Servo bb	At once
P1-02	First position loop gain	<=20P7:300 >=21P0:200	0.1/s	10~20000	Servo bb	At once
P1-05	Second speed loop gain	200	0.1Hz	10~20000	Servo bb	At once
P1-06	Second velocity loop integral constant	3300	0.01ms	15~51200	Servo bb	At once
P1-07	Second position loop gain	200	0.1/s	10~20000	Servo bb	At once

Note: Version 3770 and later added a second set of gain adjustments.

9.8.4 Gain switch

Note: the gain switching function is supported in version 3770 and later.

Parameter		Meaning	Default setting	Modify	Effective
P1-14	n.□□□0	0-SI terminal switching gain is valid(the gain switching condition parameter is not valid) 1-Perform gain switching according to gain switching conditions 2-Reserved	0	Servo bb	At once
	n.□□□1	n.□□X□: Gain switching condition selection 0- First gain fixed 1- Switching by external SI terminals 2- Large torque command 3- Large speed command 4 - Speed command changes greatly 5 - [Reserved] - fixed as the first gain 6 - Large position deviation 7 - Position command 8 - Positioning completed 9 - Large actual speed A - Position command + actual speed			
P1-15		Gain switching waiting time	5	Servo bb	At once
P1-16		Gain switching level threshold	50	Servo bb	At once
P1-17		Hysteresis of gain switching level threshold	30	Servo bb	At once
P1-18		Position loop gain switching time	2	Servo bb	At once

Note:

- (1) The gain switching waiting time is effective only when the second gain is switched back to the first gain.
- (2) The definition of gain switching level threshold hysteresis:

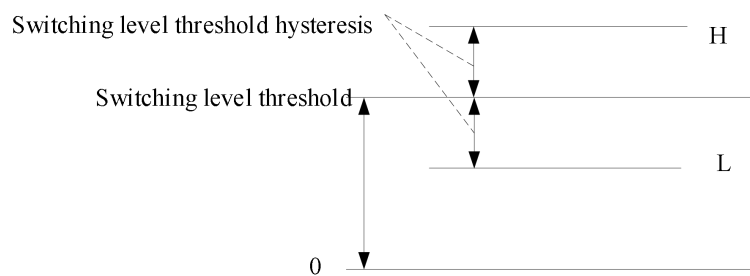

- (3) The definition of position gain switching time:

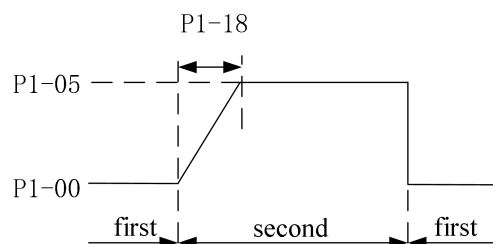

(4) Gain switching conditions:

Gain switching condition				Related parameters		
P1-14.1	Condition	Diagram	Notes	P1-15	P1-16	P1-17
0	The first gain fixed	-	-	Invalid	Invalid	Invalid
1	Terminal switching		Switch the gain through G-SEL signal: G-SEL invalid, first group of gain, G-SEL valid, second group of gain	Valid	Invalid	Invalid
2	Torque command		When the absolute value of torque command exceeds (level + hysteresis) [%] at the last first gain, switch to the second gain. At the last second gain, the absolute value of the torque command is less than (level - hysteresis) [%], and then wait until P1-15 remain in this state, return to the first gain.	Valid	Valid (%)	Valid (%)
3	Speed command		When the absolute value of the speed command exceeds (level + hysteresis) [RPM] at the last first gain, switch to the second gain. At the last second gain, when the absolute value of the speed command is less than (level - hysteresis) [RPM], wait until P1-15 remain in this state, and return to the first gain.	Valid	Valid	Valid
4	Speed command change rate		At the last first gain, when the absolute value of the speed command change rate exceeds (level + hysteresis) [10rpm/s], switch to the second gain. At the last second gain, when the absolute value of the speed command change rate is less than (level-hysteresis) [10rpm/s], wait until P1-15 remain in this state, and return to the first gain.	Valid	Valid (10rpm/s)	Valid (10rpm/s)
5	Speed command high and low speed threshold [not supported]		At the last first gain, when the absolute value of the speed command exceeds (level-hysteresis) [RPM], switch to the second gain, and the gain gradually changes. When the absolute value of the speed	Invalid	Valid (rpm)	Valid (rpm)

Gain switching condition			Related parameters			
			<p>command reaches (level + hysteresis) [RPM], the gain completely changes to the second gain.</p> <p>At the last second gain, when the absolute value of the speed command is lower than (level + hysteresis) [RPM], it starts to return to the first gain, and the gain changes gradually. When the absolute value of the speed command reaches (level-hysteresis) [RPM], the gain completely returns to the first gain.</p>			
6	Position offset		<p>Valid only in position mode (other modes are fixed as the first gain)</p> <p>When the absolute value of position deviation exceeds (level + hysteresis) [encoder unit] at the last first gain, switch to the second gain.</p> <p>When the absolute value of the position deviation is less than (level-hysteresis) [encoder unit] at the last second gain, wait until P1-15 remain in this state, and return to the first gain.</p>	Valid	Valid (Encoder unit)	Valid (Encoder unit)
7	Position command		<p>Valid only in position mode (other modes are fixed as the first gain)</p> <p>At the last first gain, if the position command is not 0, switch to the second gain.</p> <p>At the last second gain, if the position command is in the state of 0 which remains in the waiting time P1-15, it returns to the first gain.</p>	Valid	Invalid	Invalid
8	Positioning completion		<p>Valid only in position mode (other modes are fixed as the first gain)</p> <p>At the last first gain, if the positioning is not completed, switch to the second gain.</p> <p>At the last second gain, if the state of positioning completion remains in this state for the waiting time P1-15, the first gain is returned. Note: it is necessary to set the</p>	Valid	Invalid	Invalid

Gain switching condition			Related parameters			
			positioning completion detection mode according to P5-01.			
9	Actual speed	<p>The graph shows the actual speed (rpm) over time. It starts at a low speed with 'first' gain. When the speed reaches a 'Level threshold', it switches to 'second' gain. The speed then rises to a higher level. When it starts to fall, it remains at the higher level for a 'Waiting time' before switching back to 'first' gain. The graph also shows 'Threshold hysteresis' and 'Speed feedback'.</p>	<p>Valid only in position mode (other modes are fixed as the first gain):</p> <p>At the last first gain, the absolute value of the actual speed exceeds (level + hysteresis) [RPM], switching to the second gain.</p> <p>At the last second gain, when the absolute value of the inter speed is less than (level-hysteresis) [RPM], wait until P1-15 remain in this state, and return to the first gain.</p>	Valid	Valid (rpm)	Valid (rpm)
A	Position command+ actual speed	<p>The flowchart shows the logic for switching between gain levels based on the position command and actual speed. It starts with 'First gain when static'. When 'Command pulses' are received, it switches to 'Second gain when action'. If there is 'No command pulse duration delay time', it switches to 'Second gain when stable'. From 'Second gain when stable', it can return to 'First gain when static' if the actual speed is less than (switching level - switching delay). It can also return to 'Second gain when action' if the actual speed is less than the switching level. A 'Near rest only speed integral second gain/ Other first gain' condition is also shown.</p>	<p>Valid only in position mode (other modes are fixed as the first gain):</p> <p>At the last first gain, if the position command is not 0, switch to the second gain.</p> <p>At the last second gain, the state in which the position command is 0 within the waiting time P1-15, maintains the second gain.</p> <p>When the position command is 0 and the waiting time P1-15 reached, if the absolute value of the actual speed is less than (level) [RPM], the speed integral time constant is fixed at the second speed loop integral time constant (P1-07), and the others return to the first gain. If the absolute value of the actual speed is less than (level-hysteresis) [RPM], the speed integral also returns to the integral time constant of the first speed loop (P1-02).</p>	Valid	Valid (rpm)	Valid (rpm)

9.9 Gain adjustment

9.9.1 Load shaking

The following reasons cause load to shake

1. The instruction is not smooth enough when the load inertia is too large.

Solutions:

- (1) Use position instruction smoothing filter P1-25;
- (2) Optimizing the instructions of the upper device to reduce the acceleration of the instructions;
- (3) Replace the motor with greater inertia.

2. Servo gain is too small, resulting in insufficient rigidity

Solutions:

- (1) Increase the gain parameters and rigidity to enhance the anti-disturbance ability.

3. Insufficient rigidity of mechanism and equipment sloshing

Solutions:

- (1) Reducing gain parameters;
- (2) Optimize the instructions of the upper device and reduce the acceleration of the instructions.

9.9.2 Vibration

The following causes cause machine vibration:

- (1) Vibration due to inappropriate servo gain

Solutions: Reduce gain

- (2) Mechanical resonance point

Solutions: Setting notch parameters manually or through mechanical characteristic analysis

9.9.3 Noise

In adaptive mode:

- (1) Inappropriate servo gain

Solutions: Reduce the adaptive control bandwidth (P2-19).

In auto-tuning mode:

- (1) Inappropriate servo gain

Solutions: Under the mode of rapid adjustment, reduce the rigidity level.

Automatic Adjustment Mode: Reducing Model Loop Gain P2-49

- (1) Noise due to mechanical resonance

Solutions: Refer to 9.8.2 vibration.

10 Alarm

10.1 EtherCAT related communication alarm code

Alarm code	Reasons		Solution
E-800	Inaccurate ESM demand error protection	<p>The change state demand which cannot change from the present state was received.</p> <p>Init→Safeop Init→OP PreOP→OP</p> <p>- When the present state is other then OP: It remains in the present ESM state. - When the present state is OP: SafeOP ESC register AL Status Code:0011h</p>	<p>Check the change state request of host controller.</p> <p>The servo alarm can be cleared by setting SM2013+20 * (N-1) or by servo panel F0-00=1.</p>
E-801	ESM undefined request error protection	<p>The change state request which does not have a definition (except the following) was received.</p> <p>1:Request Init State 2:Request Pre-Operational State 3:Request Bootstrap State 4:Reauest Safe-operational State 8:Request Operational State</p> <p>- When the present state is other then OP: It remains in the present ESM state. - When the present state is OP: SafeOP ESC register AL Status Code:0012h</p>	<p>Check the change state request of host controller.</p> <p>The servo alarm can be cleared by setting SM2013+20 * (N-1) or by servo panel F0-00=1.</p>
E-802	Bootstrap requests error protection *1)	<p>The following change state request was received.</p> <p>3:Request Bootstrap State ESM state after alarm: Init ESC register AL Status Code:0013h</p>	<p>Check the change state request of host controller.</p> <p>The servo alarm can be cleared by setting SM2013+20 * (N-1) or by servo panel F0-00=1.</p>
E-803	Incomplete PLL error protection	<p>Phasing servo and communication(PLL lock) could not be completed even after the lapse of 1s after the start of the synchronization process.</p> <p>ESM state after alarm:PreOP ESC register AL Status Code:002Dh</p>	<p>- Check setting of DC mode. -Check whether propagation delay compensation or drift compensation is correct.</p> <p>The servo alarm can be cleared by setting SM2013+20 * (N-1) or by servo panel F0-00=1.</p>
E-804	PDO watchdog error protection	<p>Bit10 of AL Event Request(0220h) did not turn on within the time set by the ESC register addresses 0400h(Watchdog Divider) and 0420h (Watchdog Time Process Data) during PDO communication (SafeOP or OP).</p> <p>ESM state after alarm: Safe OP ESC register AL Status Code:001Bh PDO communication disconnection</p>	<ol style="list-style-type: none"> 1. Check whether the transmitting timing of PDO from host controller is constant(not stop). 2. Check whether the PDO watchdog detection delay value is too large; 3. Check whether there is a problem with the wiring of the EtherCAT communication cable and whether there is excessive noise on the cable. Replace the high-quality network cable; 4. The communication cable is reconnected, and the network cable is suspended and separated from the

Alarm code	Reasons		Solution
			power cable; 5. Turn off the interfering equipment such as welding machine and then run it again, To eliminate interference problems; Cross test to determine the fault point; The servo alarm can be cleared by setting SM2013+20 * (N-1) or by servo panel F0-00=1.
E-806	PLL error protection	Servo phasing and communication(PLL lock) separated during operation in the state of SafeOP or OP. ESM state after alarm: SafeOP ESC register AL Status Code:0032h	- Check setting of DC mode. - Check whether propagation delay compensation or drift compensation is correct. The alarm can be cleared through the servo panel F0-00=1 or the control power can be disconnected for reset.
E-807	Synchronization signal error protection	After the synchronization processing is completed, the SYNC0 or IRQ interrupt processing occurs above the set threshold ESM state after alarm:SafeOP ESC register AL Status Code:002Ch	- Check setting of DC mode. - Check whether propagation delay compensation or drift compensation is correct. The alarm can be cleared through the servo panel F0-00=1 or the control power can be disconnected for reset.
E-810	Synchronization cycle error protection	If set to cycle synchronization(SYNC0 cycle) is not supported Set synchronization cycle except 500us,1ms, 2ms, 4ms ESM state after alarm: PreOP ESC register AL Status Code: 0035h	Set up a synchronous period correctly. The servo alarm can be cleared by setting SM2013+20 * (N-1) or by servo panel F0-00=1.(Supported after 3770)
E-811	Mailbox error protection	A setup of SM0/1 was set as the unjust value. The sending and receiving area of the mailbox overlaps with SM2/3, and the address of the sending and receiving area is odd; Start address of mailbox: SyncManager0:1000h~10FFh, SyncManager1:other than 1200h~12FFh Length (ESC register:0802h, 0803h/080Ah, 080Bh) set up of SyncManager0/1 is inaccurate SyncManager0:other than 32~256byte SyncManager1:other than 40~256byte Control Register(ESC register:0804h/080Ch) set up of SyncManager0/1 is inaccurate Set code other than 0110b in 0804h: bit5-0 Set code other than 0110b in 080Ch:bit5-0 ESM state after alarm: Init ESC register AL Status Code:0016h	Set the Sync manager correctly in accordance with the ESI file descriptions. The servo alarm can be cleared by setting SM2013+20 * (N-1) or by servo panel F0-00=1.
E-814	PDO watchdog error protection	A setup of the watchdog timer of PDO is wrong.	Set up detection timeout value of watchdog timer correctly

Alarm code	Reasons		Solution
		<p>Although PDO watch dog trigger is effective (SyncManager: Bit6 which is the register 0804h set to 1), when the detection timeout value of PDO watchdog timer cycle setup (registers 0400h and 0420h) was less than "communication cycle *2".</p> <p>ESM state after alarm: PreOP ESC register AL Status Code:001Fh</p>	<p>The servo alarm can be cleared by setting SM2013+20* (N-1) or by servo panel F0-00=1.</p>
E-815	DC error protection	<p>DC setting is wrong.</p> <p>A value other than the following was set to bit 2-0 of 0981h (Activation) of the ESC register:</p> <p>bit2-0=000b; bit2-0=011b</p> <p>ESM state after alarm: PreOP ESC register AL Status Code:0030h</p>	<p>Check setting of DC mode.</p> <p>The servo alarm can be cleared by setting SM2013+20 * (N-1) or by servo panel F0-00=1.</p>
E-816	SM event mode error protection	<p>SM event mode which is not supported was set up.</p> <p>1C32/1C33-01 Set values other than 00, 01 and 02.</p> <ul style="list-style-type: none"> - When 000b was set to bit 2-0 of 0981h of the ESC register, SM2 setting was set to only either 1C32h-01h or 1C33h-01h. <p>ESM state after alarm:PreOP ESC register AL Status Code:0028h</p>	<ul style="list-style-type: none"> - 1C32h-01h(Sync mode) should set up 00h(FreeRun), 01h(SM2), or 02h(DC SYNC0). - 1C33h-01h(Sync mode) should set up 00h(FreeRun), 02h(DC SYNC0), or 22h (SM2). - Set same value to 1C32h-01h and 1C33h-01h. <p>The servo alarm can be cleared by setting SM2013+20*(N-1) or by servo panel F0-00=1.</p>
E-817	SyncManager2/3 error protection	<p>A setup of SyncManager3 was set as the unjust value.</p> <ul style="list-style-type: none"> - A Physical Start Address (ESC register 0818h) setup of SyncManager3 is inaccurate. -Receiving area overlaps with the area for the transmission. - The area for transmission/reception of Mailbox overlaps the area for transmission/reception of SyncManager2/3 - Addressing transmission and reception area is an odd number. - Start addresses is out of range. - A Length (ESC register 0812h/081Ah) setup of SyncManager2 is inaccurate. - Different from RxPDO size. - A Control Register (ESC register 0814h/081Ch) setup of SyncManager2 is inaccurate. <p>Set other than 100110b to bit5-0 ESM state after alarm: PreOP ESC register AL Status Code:001Dh/001Eh</p>	<p>The servo alarm can be cleared by setting SM2013+20*(N-1) or by servo panel F0-00=1.</p>
E-850	TxPDO assignment error protection	<p>The data size of TxPDO map is set up exceeding 24 bytes</p> <p>ESM state after alarm: PreOP ESC register AL Status Code: 0024h</p>	<p>TxPDO data size is set up within 24 bytes.</p> <p>The servo alarm can be cleared by setting SM2013+20 * (N-1) or by servo panel F0-00=1.</p>
E-851	RxPDO assignment error	<p>The data size of RxPDO map is set up exceeding 24 bytes.</p>	<p>RxPDO data size is set up within 32 bytes.</p>

Alarm code	Reasons		Solution
	protection	ESM state after alarm: PreOP ESC register AL Status Code:0025h	The servo alarm can be cleared by setting SM2013+20 * (N-1) or by servo panel F0-00=1.
E-881	Control mode setting error protection	<p>- The PDS state was changed to "Operation enabled" when the value set to 6060h (Modes of operation) is 0 and the value set to 6061h (Modes of operation display) is 0.</p> <p>Unsupported control mode is set to 6060h (Modes of operation). A control mode other than position control is set to 6060h (Modes of operation) in full-closed control.</p> <p>ESM state after alarm: It remains in the present ESM state. ESC register AL Status Code:0000h</p>	<p>Check preset value of 6060h(Modes of operation).</p> <p>The servo alarm can be cleared by setting SM2013+20 * (N-1) or by servo panel F0-00=1.</p>
E-882	ESM requirements during operation error protection	<p>- When a PDS state was "Operation enabled" or "Quick stop active", the transition command to other ESM state was received.</p> <p>ESM state after alarm: A state transition request from host controller is followed. ESC register AL Status Code: 0000h</p>	<p>Check the state transition request from higher rank equipment.</p> <p>The servo alarm can be cleared by setting SM2013+20 * (N-1) or by servo panel F0-00=1.</p>
E-883	Improper operation error protection	<p>- When EXT1/EXT2 is not assigned to input signal, EXT1/EXT2 was selected in trigger selection of a touch probe (60B8h (Touch probe function)). The calculation result of electronic gear ratio fell outside the range of 1/1000 to 1000 times;</p> <p>- In the calculation process of electronic gear ratio, the denominator or numerator exceeds an unsigned 64-bit size.</p> <p>- In the final calculation result of electronic gear ratio, the denominator or numerator exceeds an unsigned 32-bit size.</p> <p>- When Z-phase is chosen by trigger selection of a touch probe (60B8h(Touch probe function)) at the time of absolute mode of full closed.</p> <p>- When the software limit function is enabled, a wraparound occurred to the actual position or command position.</p> <p>ESM state after alarm: It remains in the present ESM state. ESC register AL Status Code:0000h</p>	The servo alarm can be cleared by setting SM2013+20 * (N-1) or by servo panel F0-00=1.
E-899	The program cannot access the bus peripherals correctly	The EEPROM of the bus is not updated correctly (updated at the factory) Bus driver related hardware error	<ol style="list-style-type: none"> 1. Update the EEPROM of the bus 2. Contact the agent or manufacturer

10.2 EtherCAT communication unrelated alarm

DS5 alarm code format is E-XX□,“XX”means main type, “□” means sub-type.

Type	Alarm code	Description	Reasons	Solutions	
EEEE	1	EEEE1	Communication error between panel and CPU	① The power supply voltage fluctuates greatly, and the panel refresh fails due to the low voltage ② The panel program is damaged ③ Communication enters into an endless loop	① Stable power supply to ensure the stability of power supply voltage; ② Power off and power on again. If the alarm cannot be removed, please contact the agent or manufacturer; ③ Check the operation after unplugging the communication terminal
	2	EEEE2			
	3	EEEE3			
	4	EEEE4			
01	0	E-010	Firmware version mismatch	Downloaded firmware version error	Please contact the agent or the manufacturer
	3	E-013	FPGA loading error	①Program damaged ②Device damaged	Please contact the agent or the manufacturer
	4	E-014	FPGA Access error	①Program damage ②Device damage ③Serious external interference	Please contact the agent or the manufacturer
	5	E-015	Program running error	Program damage	Please contact the agent or the manufacturer
	7	E-017	Processor Running Timeout	Program damage	Please contact the agent or the manufacturer
	9	E-019	System password error	Program damage	Please contact the agent or the manufacturer
02	0	E-020	Parameter loading error	Faliure of parameter self-checking	Re-energizing can restore default parameters, if there are repeated problems, please contact the agent or manufacturer.
	1	E-021	Parameter range beyond limit	Setting values are not within the prescribed range	Check parameters and reset them
	2	E-022	Parameter conflict	Conflict of TREF or VREF Function Settings	① Check whether the parameter settings meet the requirements; ② Under P0-01=4 mode, P3-00 will alarm when set to 1
	3	E-023	Sampling channel setting error	Error setting of custom output trigger channel or data monitoring channel	Check that the settings are correct
	4	E-024	Parameter conflict	Low voltage of power grid	(1) If it is single-phase 220V power supply, please connect L1 and L3. (2) show E-024 immediately after power failure (3) Resetting parameters
	5	E-025	Erase FLASH error	Abnormal parameter preservation during power failure	Please contact the agent or the manufacturer
	6	E-026	Initialization FLASH error	Power supply instability of FLASH chip	Please contact the agent or the manufacturer
	8	E-028	EEPROM write in error	Voltage instability or chip abnormality	Please contact the agent or the manufacturer
03	0	E-030	Bus voltage U0-05 is higher than the actual preset threshold, 220V Power Supply Machine (U0-05≥402V)	High voltage of power grid	Check the fluctuation of power grid, 220V driver normal voltage range 200V ~ 240V, 380V driver normal voltage range 360V ~ 420V. If the voltage fluctuation is large, it is recommended to use the correct voltage source and regulator.

Type	Alarm code	Description	Reasons	Solutions
		380V Power Supply Machine (U0-05≥780V)	Excessive load moment of inertia (insufficient regeneration capacity)	(1) Connect external regenerative resistor, (220V: bus voltage U0-05 = 392 discharge starts, U-05 = 377 discharge ends; 380V: U-05 = 750 discharge starts, U-05 = 720 discharge ends;) (2) Increase Acceleration and Deceleration Time (3) Reduce load inertia (4) Reduce start-stop frequency (5) Replacement of larger power drivers and motors
			Brake resistance damage or excessive resistance value	Check the regenerative resistor and replace the external resistor with the appropriate resistance value.
			Acceleration and deceleration time is too short	Extending Acceleration and Deceleration Time
			Hardware Fault of Driver Internal Sampling Circuit	The AC gear of the multimeter measures the input value of the servo LN (R/S/T), which is 220V ± 10% of the normal value. If the power supply voltage is more than 220V+10% (380V+10%), check the power supply voltage; if the power supply voltage is normal, then the servo BB state, monitor U0-05, the voltage measured by the multimeter * 1.414 < U0-05 (within 10V error), then the servo driver is faulty and needs to be sent back for repair.
04	0	E-040 Bus voltage U0-05 is lower than the actual preset threshold. 220V power supply machine (U0-05 ≤ 150V) 380V power supply machine (U0-05 ≤ 300V)	low voltage of power grid when normal power on	(1) Check the fluctuation of power grid. The normal voltage range of 220V driver is 200V~240V. If the voltage fluctuation is large, the voltage regulator is recommended. (2) Replacement of larger capacity transformers
			Instantaneous power failure	Re-energize after voltage stabilization
			Hardware Fault of Driver Internal Sampling Circuit	The AC gear of the multimeter measures the input value of the servo LN (R/S/T), which is 220V ± 10% of the normal value. If < 220V + 10% (380V + 10%), then check the supply voltage; if the supply voltage is normal, then servo BB state, monitoring U0-05, multimeter measurement voltage * 1.414 > U0-05 (error within 10V), then the servo driver is faulty and needs to be sent back for repair
	1	E-041	Driver power down	Driver power off
3	E-043	Bus Voltage Charging Failure	low voltage of power grid when normal power on	low voltage of power grid when normal power on
			Hardware damage	When the driver is on, please pay attention to whether there is relay

Type	Alarm code	Description	Reasons	Solutions	
				actuation sound	
	4	E-044	Three phase voltage input phase loss	Three phase input power supply is lack of phase Check the power supply	
06	0	E-060	Module temperature is too high (Module temperature U-06 \geq 90°C alarm, U-06 \geq 70°C Warning)	Running under heavy load for a long time	Re-consider the capacity of the motor, monitor the U0-02 torque during operation, whether it is in the value of more than 100 for a long time, if yes, please chose the large-capacity motor or load reduction.
				Excessive ambient temperature	(1) Enhance ventilation measures to reduce ambient temperature; (2) Check whether the fan rotates when the servo is enabled; when the module temperature U-06 \geq 45°C, the fan opens.
				Fan damage	Replace the fan
	1	E-061	Motor overheat	Alarm when motor temperature is higher than 95°C	① Check whether the motor fan is abnormal ② Contact the manufacturer
	3	E-063	Thermocouple disconnection alarm	① The motor thermocouple of 11kw and above power is disconnected ② False opening detection and disconnection alarm of motor below 11kw	Check the external thermocouple connection; Shield thermocouple disconnection alarm: P0-69.1 = 1
08	0	E-080	Overspeed (actual speed \geq P3-21/P3-22) The maximum forward speed is P3-21 and the maximum reverse speed is P3-22.	Motor code not match	Check if the driver P0-33 is identical with the motor code of the motor label (the number after MOTOR CODE), if not, please change to the same one, then power on again.
				UVW wiring error	Inspection of motor UVW wiring, need to be connected in phase sequence.
				Motor speed too fast	(1) The maximum speed limit value P3-21/P3-22 was reduced. (2) To confirm whether the external force makes the motor rotate too fast, whether the pulse input frequency is too high, and whether the electronic gear ratio is too large.
				Encoder fault	(1) Check the encoder cable or change a new one (2) Set the servo driver to BB state and the driver to U-10. Rotate the motor shaft slowly by hand to see if the value of U-10 changes normally, increasing in one direction and decreasing in one direction (0-9999 cycle display).
				Parameter setting	When the actual speed is greater than the P3-21/P3-22 value, an alarm will be given
	2	E-082	Encoder zero position deviation protection 1	Causes of UVW three-phase wrong wiring, motor encoder zero position deviation, etc	① Check whether the three phases of the power line are connected according to the phase sequence of UVW ② Check the encoder zero position,

Type	Alarm code	Description	Reasons	Solutions	
				please contact the manufacturer's technical support	
09	2	E-092	Analog Tref Zero-Calibration Over limit	Analog Zero Calibration Operation Error	Please correct zero without analog voltage
	3	E-093	Analog Vref Zero-Calibration Over limit	Analog Zero Calibration Operation Error	Please correct zero without analog voltage
10	0	E-100	Position offset too large	In position control, the difference between the given position and the actual position exceeds the limit value	(1) Observe whether the motor is blocked or not. (2) Reducing the given speed of position; (3) Increase the deviation pulse limit P0-23.
	1	E-101	Sudden change of position command	The position difference every 6K cycle exceeds the command difference alarm value set in P0-70	① Check and modify the procedure; ② Set appropriate P0-70 value
11	0	E-110	External UVW Short Circuit Discovered in Self-Inspection		①Check UVW wiring, need to be in phase sequence (brown U, black V, blue W) ②Measure whether the UVW phase resistance of the motor is balanced. If the phase resistance is unbalanced, replace the motor. Measure whether there is short circuit between UVW and PE of the motor. If there is short circuit, replace the motor. Measure the driver side UVW output through multimeter (diode gear), black pen P+, red pen to measure UVW; red pen P-, black pen to measure UVW; if anyone is 0 in 6 groups of value, replace the driver. ③It is suggested that the motor should be operated on an empty shaft to eliminate the load problem. ④Increase Acceleration and Deceleration Time ⑤Check the encoder cable or change a new one. Set the servo driver to BB state and the driver to U-10. Rotate the motor shaft slowly by hand to see if the value of U-10 changes normally, increasing in one direction and decreasing in one direction (0-9999 cycle display).
	2	E-112	U phase current overcurrent		
	3	E-113	V phase current overcurrent		
15	0	E-150	Power cable disconnection	Any phase in UVW of driver, cable or motor broken	Disconnect the power supply of the driver and check the connection of the power cable. It is suggested that the multimeter be used to test the condition. After clearing the errors, the driver should be re-energized.
16	1	E-161	Driver thermal	Overload, the actual	Increase the capacity of drivers and

Type	Alarm code	Description	Reasons	Solutions
		power overload	operating torque exceeds the rated torque, and continuous operation for a long time. (Monitor U0-02 to check the actual operating torque. If the motor is in normal operation, it will not jam or jitter. If the U0-02 is longer than 100, it will be considered improper selection of the motor.)	motors. Extend the acceleration and deceleration time and reduce the load. Monitor the U-00, whether it is running over speed.
			Mechanisms are impacted, suddenly weighted and distorted.	Eliminate mechanical distortion. Reduce load
			Motor action when motor brake is not opened	Measure the voltage of the brake terminal and decide to open the brake. It is suggested to use servo BK signal to control the brake lock. If it is not servo control, attention must be paid to the timing of brake opening and motor action.
			Wrong wiring of encoder cable, power cable or broken wire or loose pin of connector plug	Check the UVW connection of power cable to see if there is any phase sequence error. The multimeter is used to measure whether all the encoder cable are on. Check whether the plug is loose, for machine vibration, whether the plug has shrinkage pin, virtual welding, damage.
			In multiple mechanical wirings, incorrect connection of motor cable to other shafts leads to incorrect wiring.	Detection of servo wiring, the motor cable, encoder cable are correctly connected to the corresponding shaft.
			Poor gain adjustment results in motor vibration, back and forth swing and abnormal noise.	Readjustment of gain parameters
			Driver or motor hardware failure	There are servo cross test or motor empty shaft on site, F1-01 trial operation, F1-00 jog run can not rotate uniformly; Replace the new driver or motor
5	E-165	Anti-blocking alarm Judging that the current motor output torque is greater than P3-28/P3-29 (internal forward/reverse torque limit), and the time reaches P0-74 (unit ms), and the speed is	(1) Machinery is impacted, suddenly becomes heavier and distorted; (2) When the brake of the motor is not opened, the motor moves; (3) The parameter setting is unreasonable.	(1) Eliminate the factors of mechanical distortion. Reduce load (2) Measure the voltage of the brake terminal and determine the opening of the brake; It is suggested to use servo BK brake signal to control the brake lock. If it is not servo control, attention must be paid to the timing of brake opening and motor action. (3) Monitor the actual output torque range of U0-02 and check whether the setting of P3-28/29 torque limit is reasonable. (After version 3760, the

Type		Alarm code	Description	Reasons	Solutions
			lower than P0-75 (unit 1 rpm).		output torque limit setting parameters of anti locked rotor alarm are P3-38 and P3-39)
20	0	E-200	Regenerative resistance overload	High Voltage Fluctuation in Power Grid	Stable the input voltage
				Selection of regenerative resistance is too small	Replacement of higher power regenerative resistors (refer to chapter 1.4.1)
				Acceleration and deceleration time is too short	Extending Acceleration and Deceleration Time
				Hardware damage	The AC gear of the multimeter measures the input value of the servo LN (R/S/T), which is $220V \pm 10\%$ of the normal value. If the power supply voltage is more than $220V+10\%$ ($380V+10\%$), check the power supply voltage; if the power supply voltage is normal, then in servo BB state, monitor U0-05, the voltage measured by the multimeter * $1.414 < U0-05$ (within 10V error), then the servo driver is faulty and needs to be sent back for repair.
22	0	E-220	Communication error of absolute servo encoder	Motor matching error	Check if the motor matches correctly
				Unconnected encoder cable or poor contact	Check whether the value of U0-54 increases rapidly. If yes, the encoder circuit is disconnected. Disconnect the power supply of the driver, check the connection of the encoder cable, if there is cable loosening, it is recommended to use the multimeter to test the conduction condition; after eliminating errors, power on again Hot plugging is strictly prohibited, and special cables are required for tank chains.
				Received encoder data errors, and the number of errors exceeds the number of error retries of encoder registers P0-56	Check whether the value of U0-79 and U0-54 increase. If yes, the encoder is interfered. Encoder wire and strong power do not have the same pipeline wiring; install filter on servo driver power input side; encoder wire sleeves magnetic ring; shut down welding machine type of equipment with large interference
	1	E-221	Too many CRC errors in encoder communication	The received encoder data is wrong and the number of errors exceeds the value in encoder error retry number register P0-56	Encoder interfered, isolate interference source
	2	E-222	Absolute value servo encoder battery low voltage alarm (can shield this alarm)	Battery Voltage in Battery Box of Encoder cable is less than 2.75V	Please replace the battery while keeping the power supply ON of the servo driver in order to avoid the error of encoder position information. Battery specification: No.5 battery, 3.6V (model CP-B-BATT, CPT-B-BATT)

Type	Alarm code	Description	Reasons	Solutions
			Power on alarm for new machine	<p>(1) When the absolute value motor is powered off, the memory position depends on the battery on the encoder cable. Once the encoder cable and the motor are disconnected, the power supply can not be carried out, which will lead to the loss of the current position of the motor, it will alarm 222. Please set F0-00=1 to clear the alarm, it can be used normally.</p> <p>(2) The alarm can be shielded by using F0-79. When P0-79 is set to 1, it will be used as a single-loop absolute value motor, and the current position will not be remembered when power off.</p>
3	E-223	Data access alarm of absolute value servo encoder	<p>Encoder cable with battery box is not used for multi-turn absolute motor</p> <p>Generally, it is the problem of the encoder itself, or the power supply of the encoder is unstable</p> <p>Abnormal power on of main control chip of multi-turn absolute value servo encoder</p> <p>ADC sampling is out of range, some resistance and capacitance devices have problems or the signal consistency of magnetic sensor is poor</p>	<p>① Please use encoder cable with battery box;</p> <p>② Power off and power on again (the driver panel shall be completely off). If the alarm cannot be removed, please contact the agent or manufacturer</p>
7	E-227	Power on encoder multi turn signal data error	Generally, it is the problem of the encoder itself, or the power supply of the encoder is unstable	In the case of no battery, unplugging the encoder cable may cause this alarm.
8	E-228	Absolute value servo encoder value overflow	The motor runs in one direction continuously, the encoder data value is too large, overflow	<p>① Set F1-06 = 1, clear the absolute encoder's multiple turns;</p> <p>② Set P0-79 = 2, the alarm can be shielded.</p>
9	E-229	Encoder electrical angle zero position deviation protection	When the encoder zero position is offset, or the motor power line phase sequence is connected incorrectly, the motor gets wrong data during control calculation due to the large electrical angle deviation used for control, which may cause the motor to gallop and cause the electrical angle zero position deviation alarm if it cannot work	<p>① Check whether the three phases of the power line are connected according to the phase sequence of UVW</p> <p>② Check the encoder zero position.</p>

Type	Alarm code	Description	Reasons	Solutions	
			normally。		
24	0	E-240	Timing error in fetching encoder position data	<p>① The number of consecutive errors in encoder data update sequence is greater than the value in P0-68</p> <p>② CPU timer fluctuates</p>	<p>① Restart driver</p> <p>② Check the arrangement of transmission cables to ensure that the strong and weak current are wired separately.</p> <p>③ High current equipment is supplied separately.</p> <p>④ The grounding is good.</p>
	1	E-241	Encoder responding data scrambling	The received encoder data is wrong and the number of errors exceeds the value in encoder error retry number register P0-56	<p>① Check the arrangement of transmission cables to ensure that the strong and weak current are wired separately.</p> <p>② High current equipment is supplied separately.</p> <p>③ The grounding is good.</p>
26	0	E-260	Over range alarm	Overrun signal was detected and the overrun processing mode was configured to alarm	If you do not want to alarm immediately when the overrun occurs, you can change the overrun signal processing mode.
	1	E-261	Overrun signal connection error	<p>(1) When the motor is in forward rotation, it encounters reverse overrun signal.</p> <p>(2) When the motor is in reverse rotation, it encounters forward overrun signal.</p>	Check over-run signal connection and over-run terminal allocation.
	2	E-262	Control stop timeout	<p>(1) Excessive inertia</p> <p>(2) Stop timeouts too short</p> <p>(3) The setting of braking torque is too small.</p>	<p>(1) Reduce inertia or use brake motor;</p> <p>(2) Increase the stop timeout time P0-30;</p> <p>(3) Increase braking torque P3-32.</p>
	4	E-264	Excessive vibration	<p>(1) Oscillation caused by external forces</p> <p>(2) Load inertia is large and the setting of load inertia ratio is wrong or the gain is too small, which leads to the oscillation of positioning.</p>	<p>(1) Check the source of external force to see if there are any problems in mechanical installation;</p> <p>(2) Increase the servo gain to improve the anti-disturbance ability;</p> <p>(3) Acquisition speed curve analysis; When the first three peaks are converged after pulse instruction completed ($0.8 * \text{first peak} > \text{second peak}$ and $0.8 * \text{second peak} > \text{third peak}$), the driver should not alarm, which can adjust the relevant threshold. When the first three peaks speed are not less than 300 rpm for three consecutive times after the completion of the pulse instruction, the driver will alarm.</p>
	5	E-265	Excessive motor vibration	Mechanical vibration	Check the motor installation
28	0	E-280	Failed to read motor parameters	Request to read EEPROM failed	On the premise that the driver and motor are matched and can be used together, read the alarm shielding position of motor parameters through P0-53, and set the motor code of P0-33 correctly
	1	E-281	Error writing data	Request to write	On the premise that the driver and motor

Type	Alarm code	Description	Reasons	Solutions	
		to encoder EEPROM	EEPROM failed	are matched and can be used together, read the alarm shielding position of motor parameters through P0-53, and set the motor code of P0-33 correctly	
31	0	E-310	Power mismatch between driver and motor	Such as 750W driver with 200W motor	Match the correct motor and driver, and use it after setting the P0-33 motor code correctly
	1	E-311	When the motor code is read automatically, the motor parameter is 0, and the driver P0-33 = 0	Motor code not set	On the premise that the driver and motor are matched and can be used together, read the alarm shielding position of motor parameters through P0-53, and set the motor code of P0-33 correctly
	2	E-312	Reading motor parameter is damaged	Parameter verification failed	CRC On the premise that the driver and motor are matched and can be used together, read the alarm shielding position of motor parameters through P0-53, and set the motor code of P0-33 correctly
	3	E-313	Encoder software version mismatch	Encoder software version mismatch	① Update driver firmware to maximize current motor parameter performance ② Read the alarm shielding position of motor parameters through p0-53, and set the motor code of P0-33 correctly. At this time, the motor parameters are in the driver, which can work normally, but may affect some performance
	4	E-314	Motor code does not match software version	Encoder hardware version is higher than driver firmware version	Contact the manufacturer's technical support to update the driver firmware
	5	E-315	When the motor code is read automatically, the motor parameter is 0, and the driver P0-33 ≠ 0	Read the motor code is 0	On the premise that the driver and motor are matched and can be used together, read the alarm shielding position of motor parameters through P0-53, and set the motor code of P0-33 correctly
	6	E-316	Auto-read code error	The auto read motor code is inconsistent with the motor code set in P0-33	Check U3-00 and motor label. ① If the two values are the same, change P0-33 motor code or set P0-33 to 0 to read motor code automatically; ② If the two values are different, contact the manufacturer for technical support
32	0	E-320	Driver cascading alarm	Terminal emergency alarm function	Check if there are alarm output signals from other drivers connected to the SI input terminal of the driver, and prioritize processing this alarm. Correctly setting parameters P5-68

10.3 Alarm read

0000H ~ FEFFh is defined according to IEC61800-7-201.

FF00h ~ FFFFh can be defined according to users, as follows.

The lower 8 bits of the defined value (FF00h ~ FFFFh) shown in the following table indicates the main code of the alarm number of the servo abnormal (alarm). (the secondary code of the alarm number is not read.)

In addition, the main code of alarm number is represented by hexadecimal number.

Index	Sub-Index	Name/Description	Range	DateType	Access	PDO	Op-mode
603Fh	00h	Error code	0~65535	U16	ro	TxPDO	All
<p>Now the alarm of the servo driver (only the main number). When the alarm does not occur, it will display 0000H. When an alarm occurs, an alarm is displayed.</p> <p>FF**h Alarm (main) No. (00h ~ FFh) (Example) FF03h ... 03h = 3d E-030 (overvoltage protection) occurs FF55h ... 55h = 85d E-850 (TxPDO configuration error protection), E-851 (RxPDO configuration error protection) any one of them occurs As an exception, A000h is displayed in the case of E-817 (Syncmanager 2/3 setting error).</p>							

Alarm code can also be read through SDO instruction. U1-00 corresponding object dictionary is 0x3100. The command is as follows:



Read the value in slave object dictionary 0x3100: 00 (current alarm code) with station number 0 to register D0. (Refer to *XDHXLH motion control manual* for the specific use of this instruction)

10.4 Alarm clear

Reset method of protection function associated with EtherCAT that can be cleared in case of abnormal (alarm)

The following methods ①②③④ can be used for abnormal (alarm) clearing no matter which method.

In addition, for protection functions other than EtherCAT association, please refer to the basic function specifications of technical manual.

Method ①: bit4 (Error Ind ACK) of AL control is set to "1".

After that, bit7 of 6040h (control word) is cleared by setting 0→1 (sending Fault result command).

After the alarm is cleared, the PDS status is converted from Fault to Switch on disabled.

Method ②: carry out abnormal (alarm) clearing by servo driver (panel F0-00, upper computer software).

After the alarm is cleared, the PDS status is transferred from Fault to Switch on disabled.

Method ③: the external alarm clear input (A-CLR) of servo driver changes from OFF state to ON state.

After the alarm is cleared, the PDS status is migrated from Fault to Switch on disabled.

Method ④: Clear the alarm through SDO instruction. The object dictionary corresponding to F0-00 is 0x4000.

The command is as follows:



When an alarm occurs, write 1 to D0 to clear the alarm.

(Refer to *XDHXLH motion control manual* for the specific use of this instruction)

11 Applications

11.1 XINJE XG2/XDH and DS5C1 Ethercat communication

11.1.1 System configuration

Name	Model	Quantity	Note
Software	Xinje PLC software	1	
Xinje servo	DS5C1-20P4-PTA	1	
Cable	JC-CA-3	some	Connect servo and PC

11.1.2 System topology

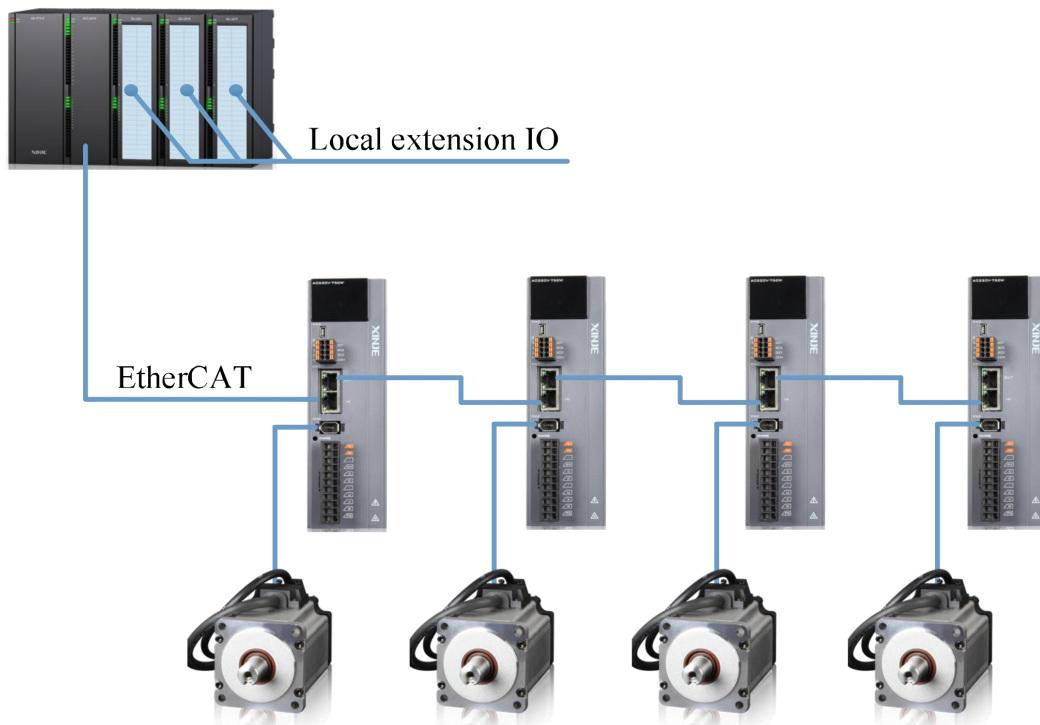

The DS5C1 driver's network interface plug-in follows the standard of bottom in and top out. For example, the network cable from the master station is connected to the second network interface in front of the first driver, and the network cable from the first network interface is connected to the second network interface in front of the second driver, and so on.

11.1.3 Debugging steps

1) CSP mode operation example

Register	Note	Unit
RXPDO[0x607A]	Position setting, Modification via IO mapping in CSP mode is invalid, which is controlled by NC module	Command unit
TXPDO[0x6064]	Position feedback (motor actual position)	Command unit
TXPDO[0x606C]	Speed feedback	Command unit /s
RXPDO[0x6060]	Set to 8	-

① Click **【scan】** or **【add】** in the EtherCAT interface, **【general】** interface please use default settings.

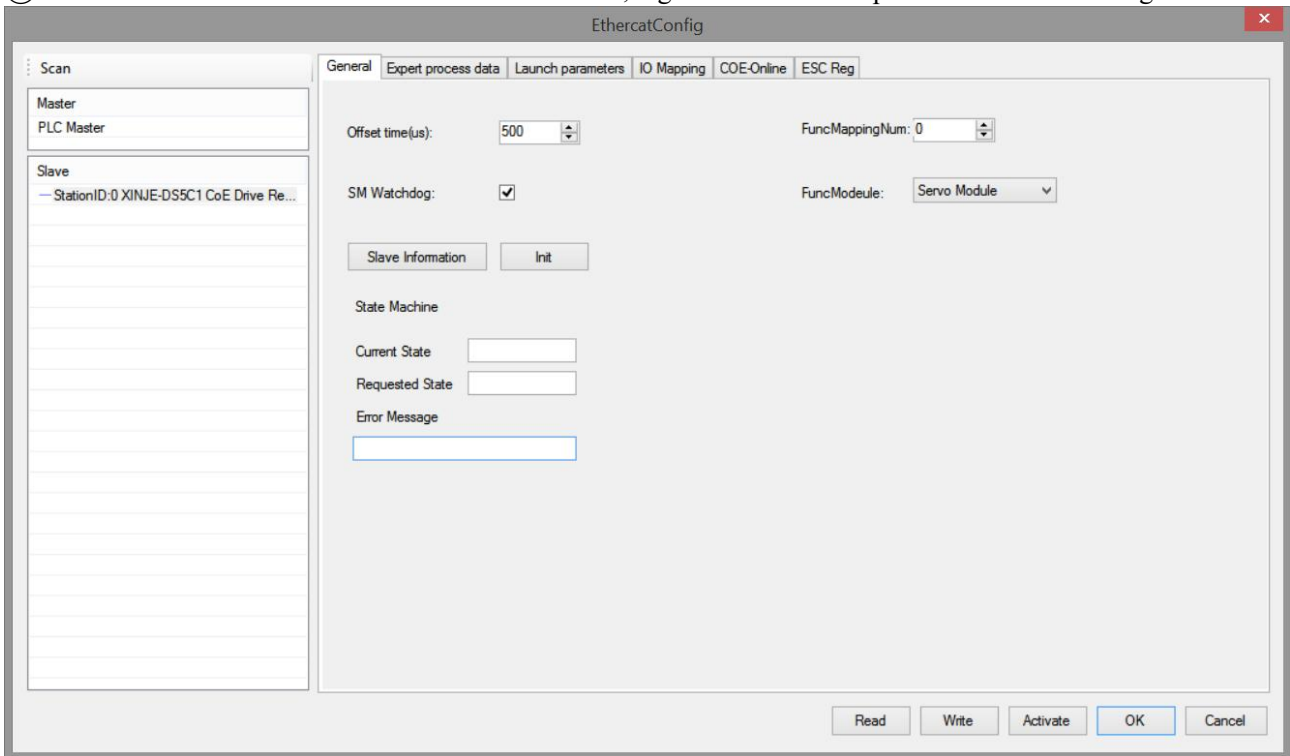

② Click **【Expert process data】** → **【PDO assign】**, select 1600, 1A00. (The default configuration can meet the basic use of CSP. If necessary, other PDO parameters can be added.)

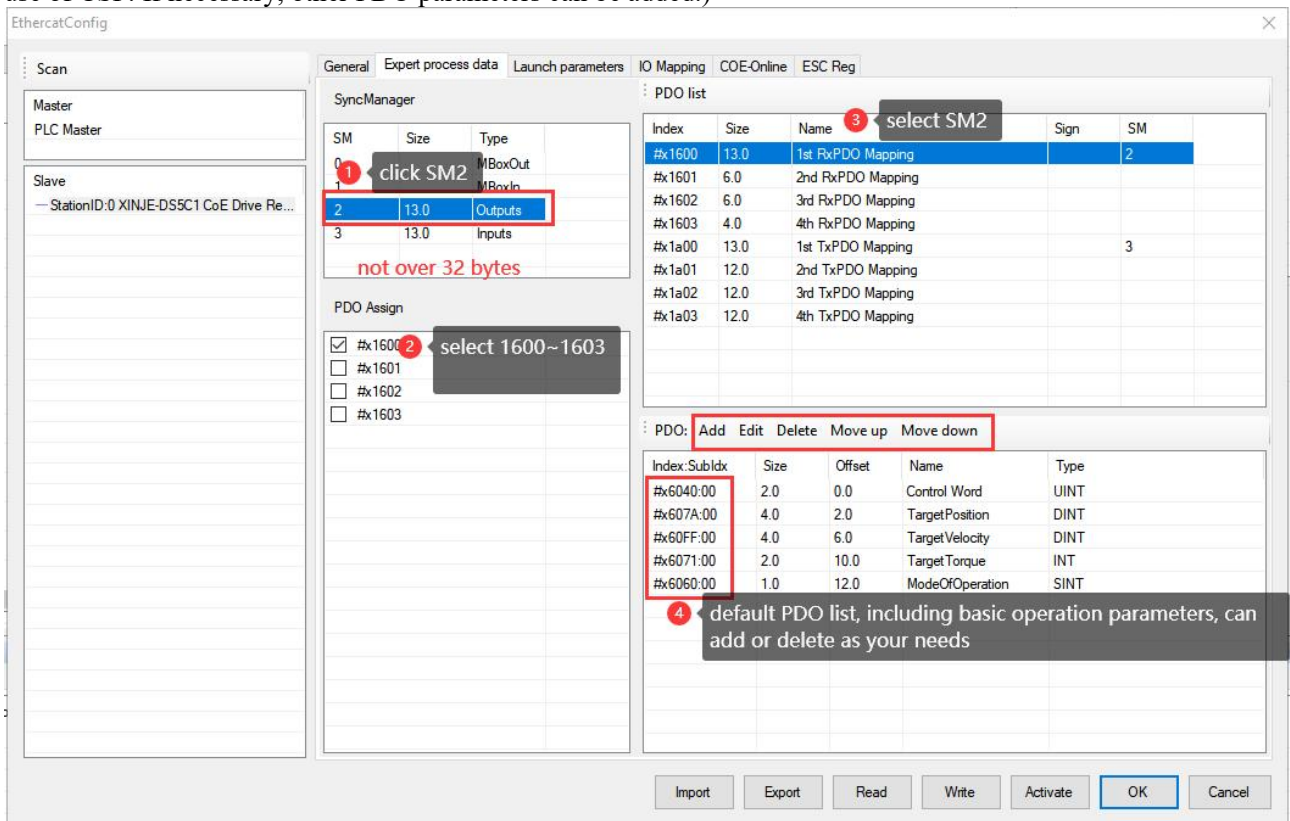

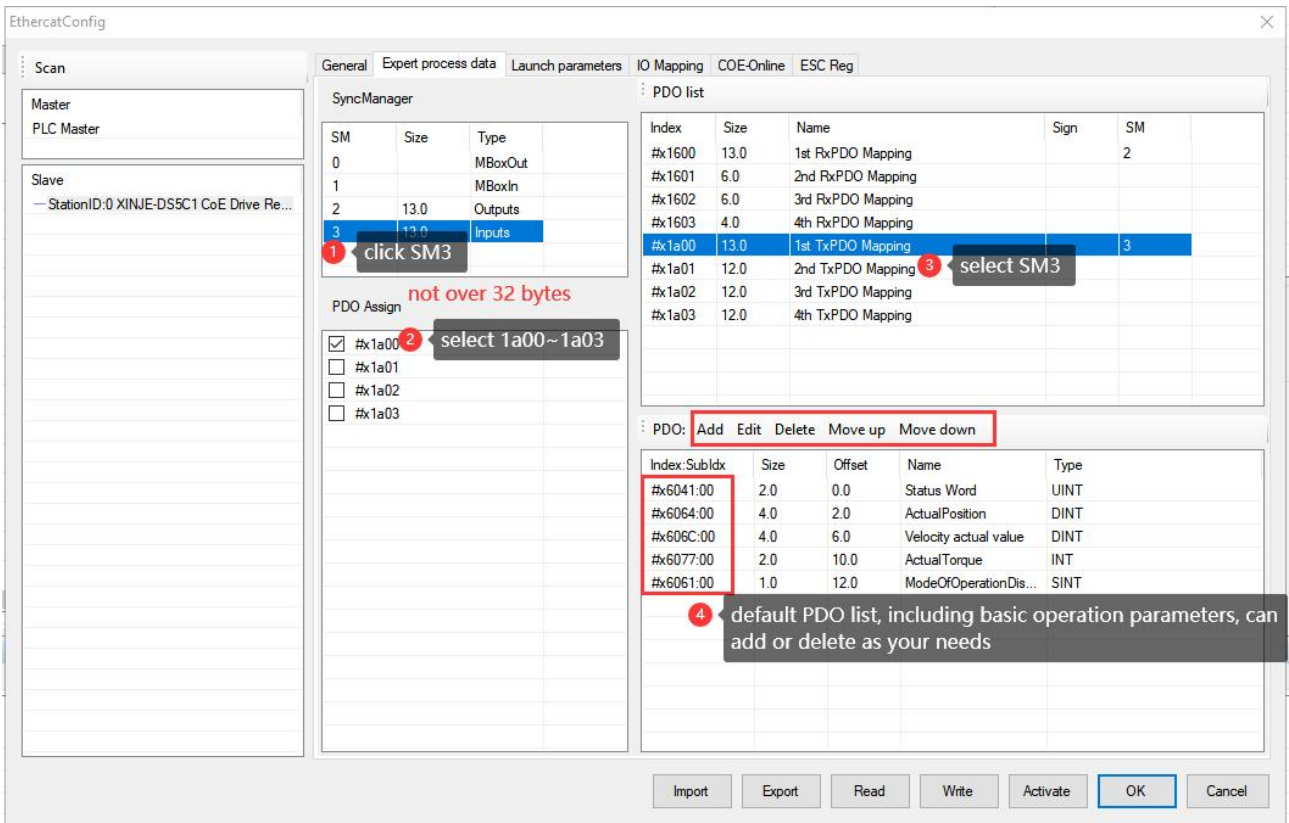

③ Confirm 6060h value is 8 in 【Launch parameters】.

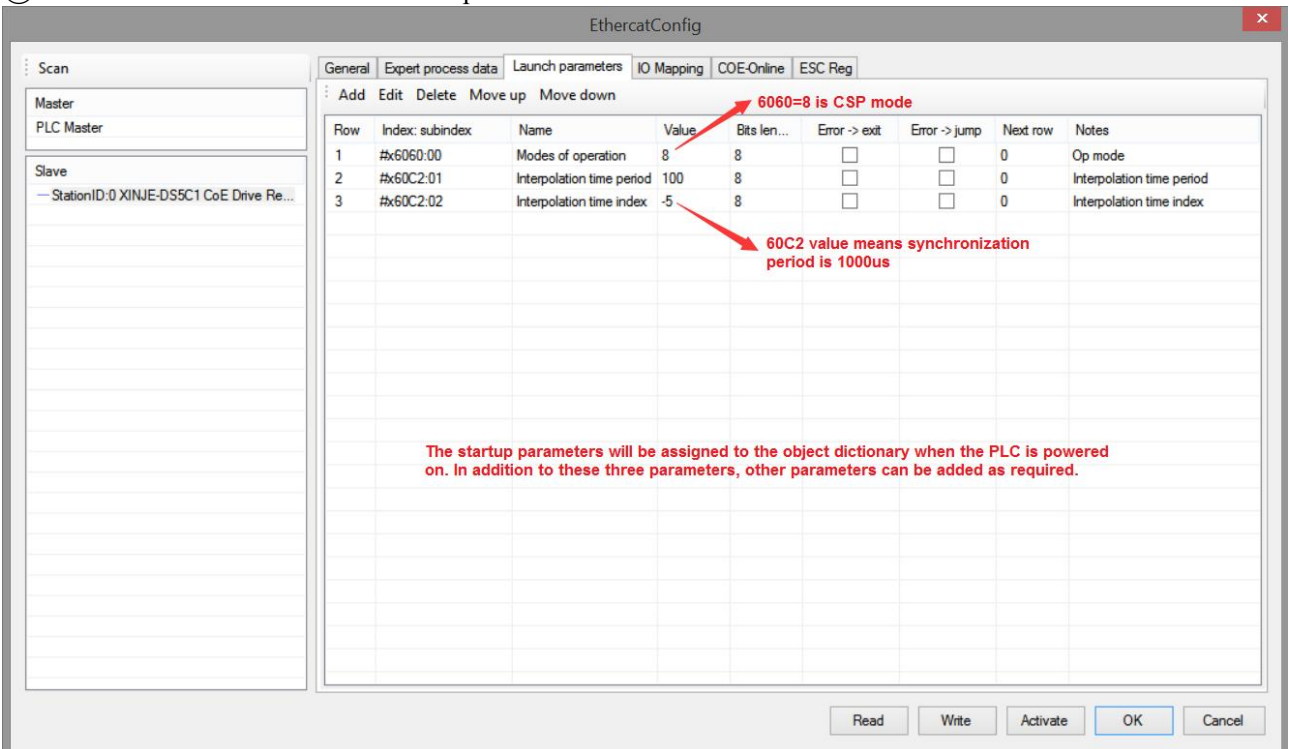

There are three default configurations in the startup parameters, among which 6060h is the slave operation mode, with a default value of 8 (CSP mode); 60C2-1 and 60C2-2 are synchronization unit cycles, 60C2-1 is the value of synchronization unit cycle, and 60C2-2 is the unit of synchronization unit cycle. For example, the default synchronization unit cycle is 100×10^{-5} s, which is 1000us. (This parameter will automatically change with the synchronization cycle of the main station configuration and does not require manual modification).

④ 【IO mapping】 default start address is HD10000, which can be changed if necessary.

⑤ After setting all the parameters, click 【write】 → 【activate】 → 【OK】. The parameters will take effect after the activation is successful.

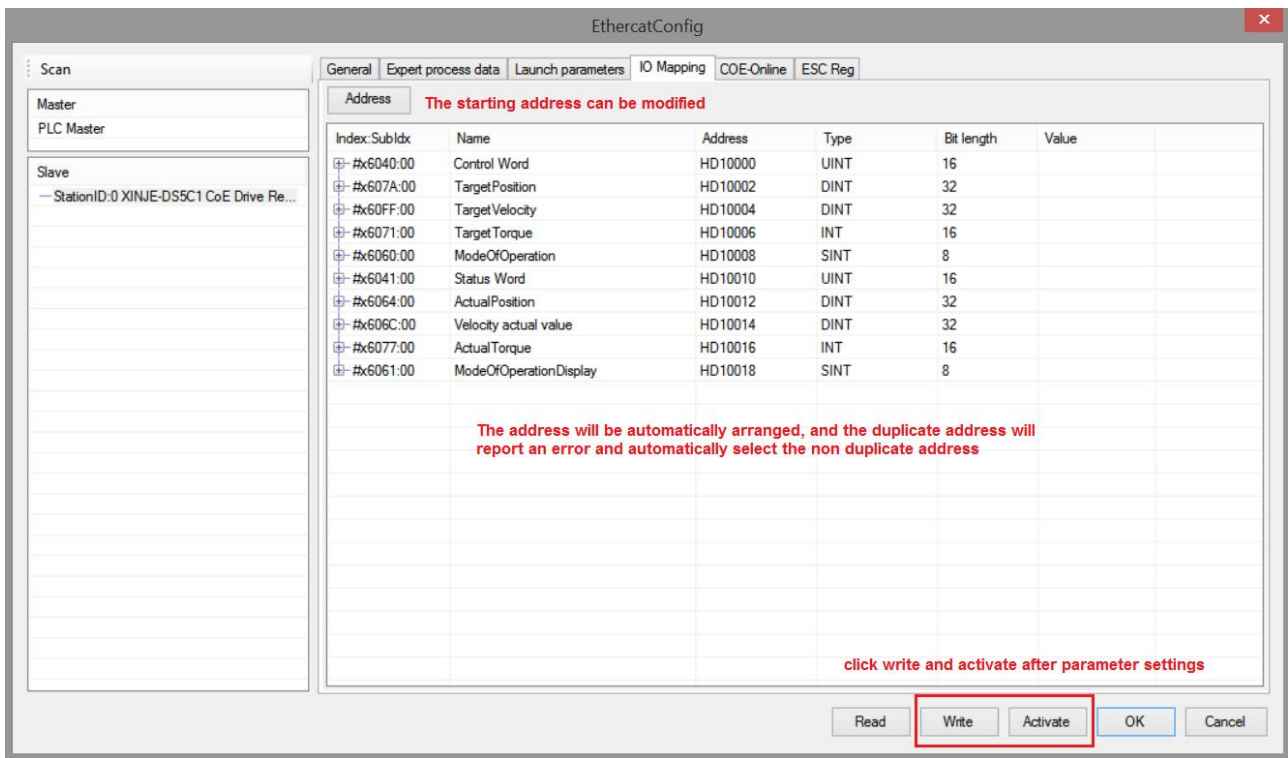

- ⑥ After the activation is completed, the slave station state machine (SD8021) will change state from 1 → 2 → 4 → 8, 8 means OP state. At this time, both SDO and PDO can receive and send messages.
- ⑦ Confirm that the instruction channel (SFD8001+300*N) in the axis configuration parameters is Ethercat (register value is 0).

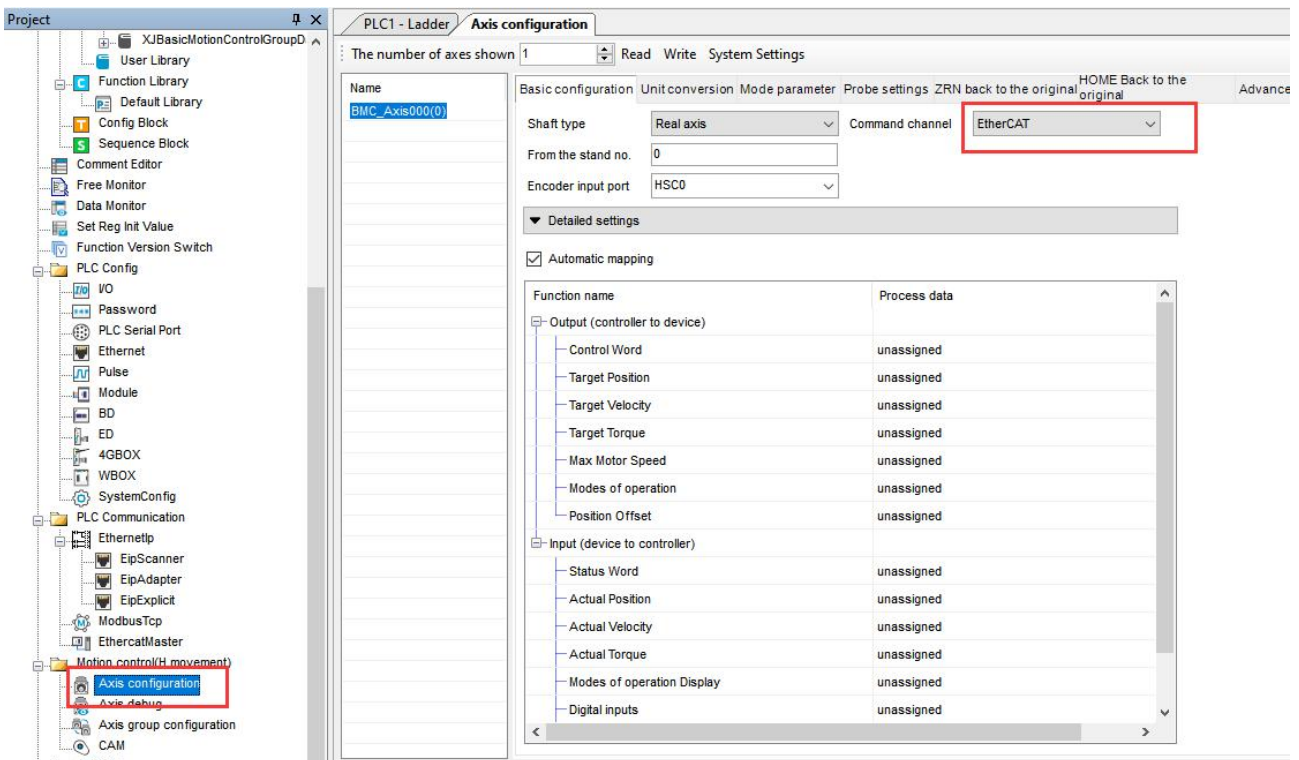

- ⑧ In CSP mode, the current given position can be monitored through HD10002 (mapping of 607Ah), the current actual position of the motor can be monitored through HD10012 (mapping of 6064h), and the current actual speed can be monitored through HD10014 (mapping of 606Ch).

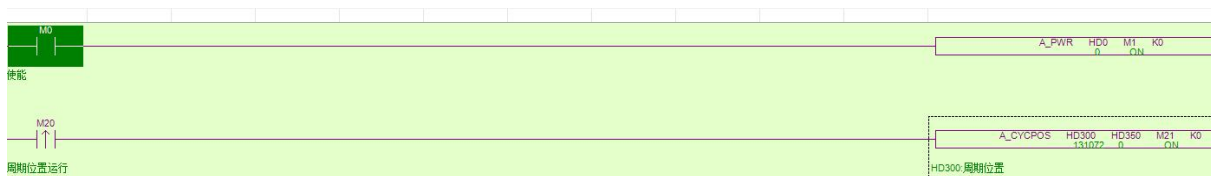

PLC1-自由监控1

监控窗口 | 添加 | 修改 | 删除 | 全部删除 | 上移 | 下移 | 置顶 | 置底

名称	监控值	类型	映射地址/字长	注释
M0	ON	BIT	位	使能
M20	OFF	BIT	位	周期位置运行
HD300	131072	LREAL	四字	周期位置
HD10002	131072	DINT	双字	Station ID:0,#x607A:0,Target position
HD10008	8	INT	单字	Station ID:0,#x6060:0,Modes of operation
HD10012	131072	DINT	双字	Station ID:0,#x6064:0,Position actual value
HD10004	0	DINT	双字	Station ID:0,#x60FF:0,Target velocity
SFD811	1	INT	单字	运动控制功能: 0-简单型; 1-入门实用型;

- ◆ When M20 goes from OFF to ON, perform periodic position control on the axis specified by HD300. After successful execution, M21 is set to ON to indicate that the axis is in a periodic control state. By periodically assigning values to HD300, control of the axis is achieved.
- ◆ Before triggering the command, please ensure that the value of HD300 is the same as the current position, otherwise the position will generate a step.
- ◆ Periodic position control requires periodic writing of the target position value into the register, with no significant changes in position, to avoid causing the axis to fly due to a large difference between the given cycle position and the previous cycle position.

2) CSV mode operation example

Register	Explanation	Unit
RXPDO[0x60FF]	Target velocity	Command unit/s
TXPDO[0x6064]	Position actual value	Command unit
TXPDO[0x606C]	Velocity actual value	Command unit /s
RXPDO[0x6080]	Max motor speed ,can be modified online through COE-Online	r/min
RXPDO[0x6060]	Set to 9	-

① Click **【scan】** or **【add】** in the EtherCAT interface, **【general】** interface please use default settings.

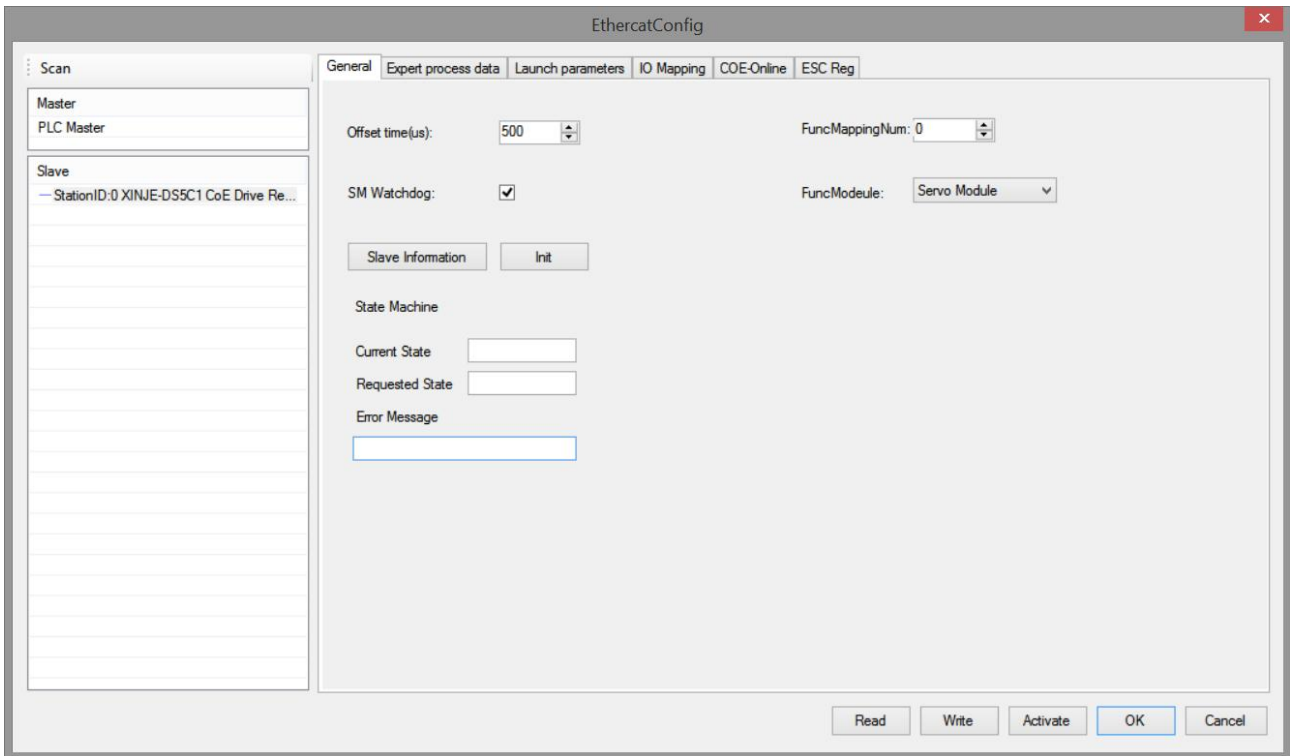

② Click **【Expert process data】** → **【PDO list】**, select 1600, 1A00. (The default configuration can meet the basic use of CSV. If necessary, other PDO parameters can be added.)

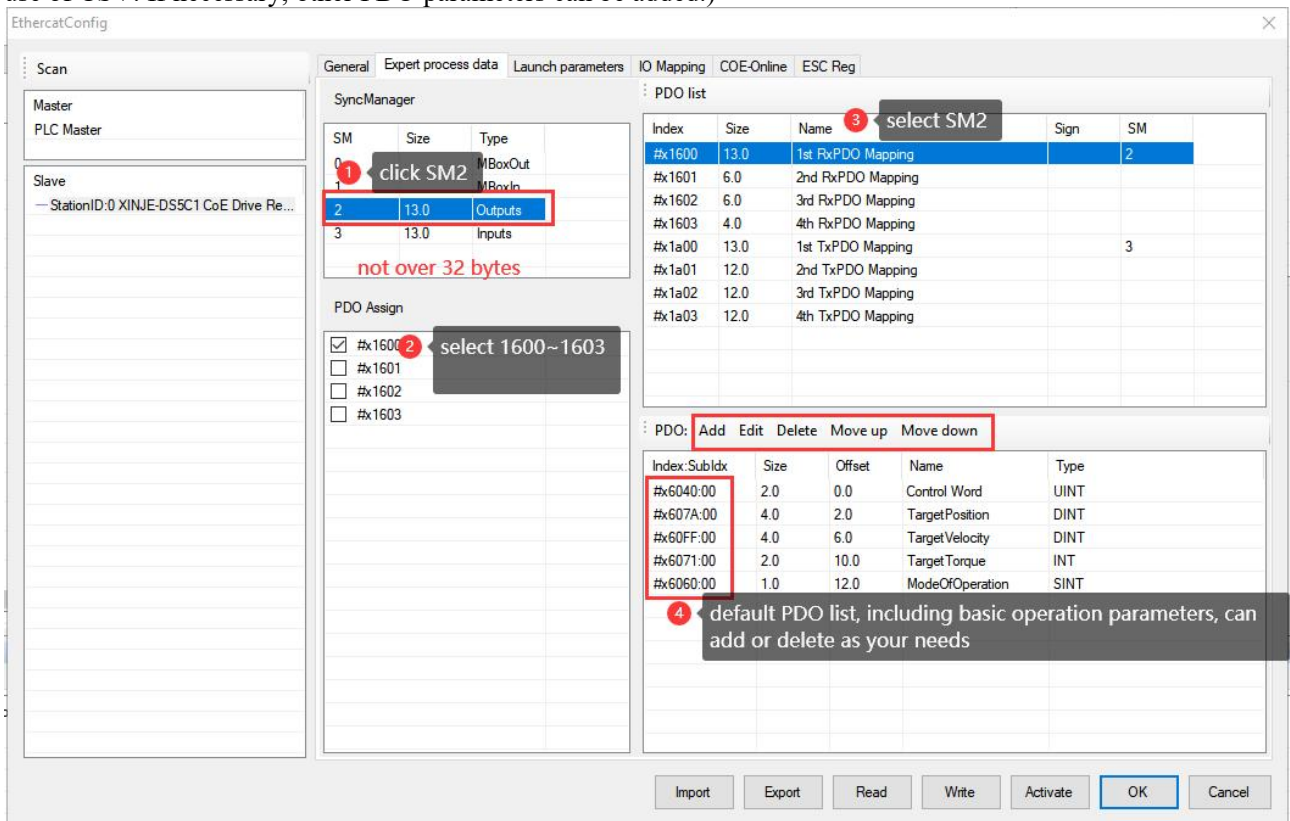

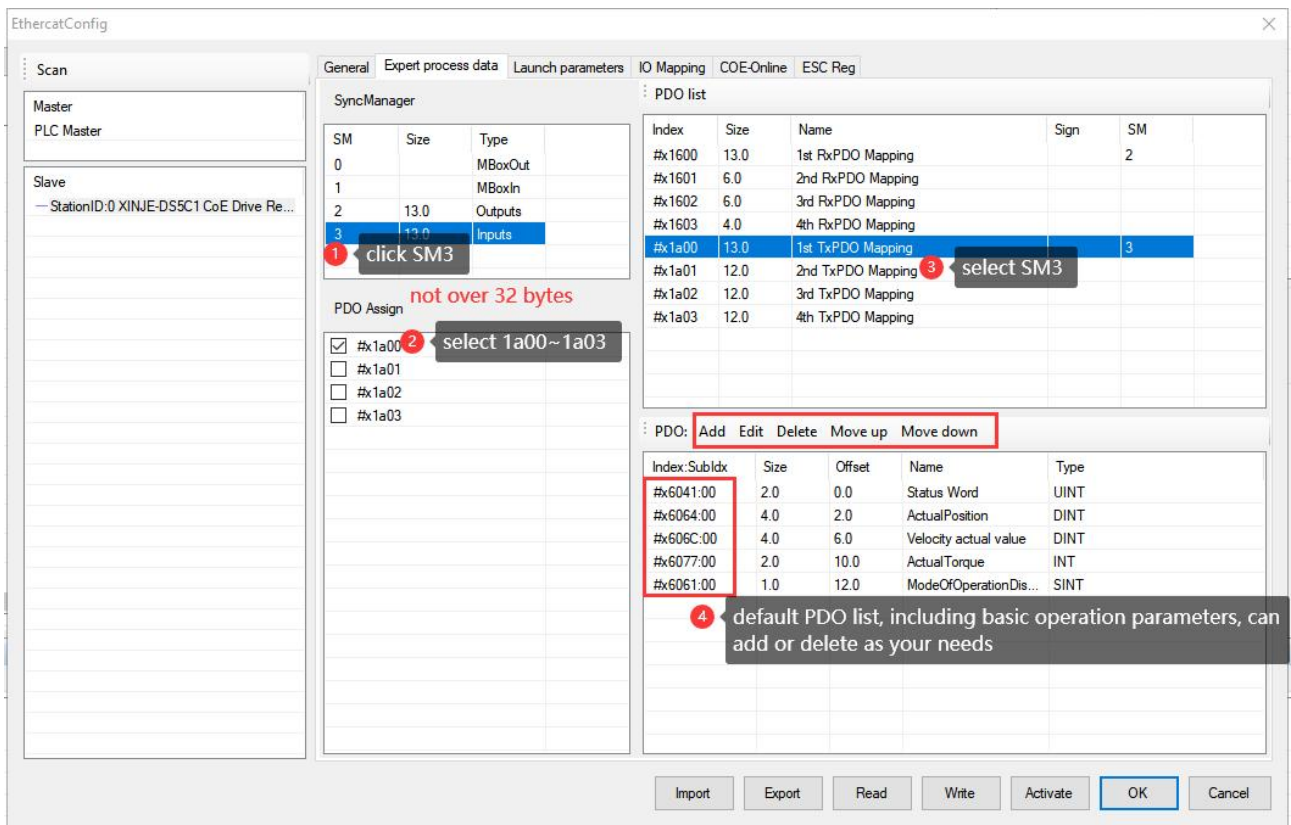

③ Confirm 6060h value in 【Launch parameters】 is 9.

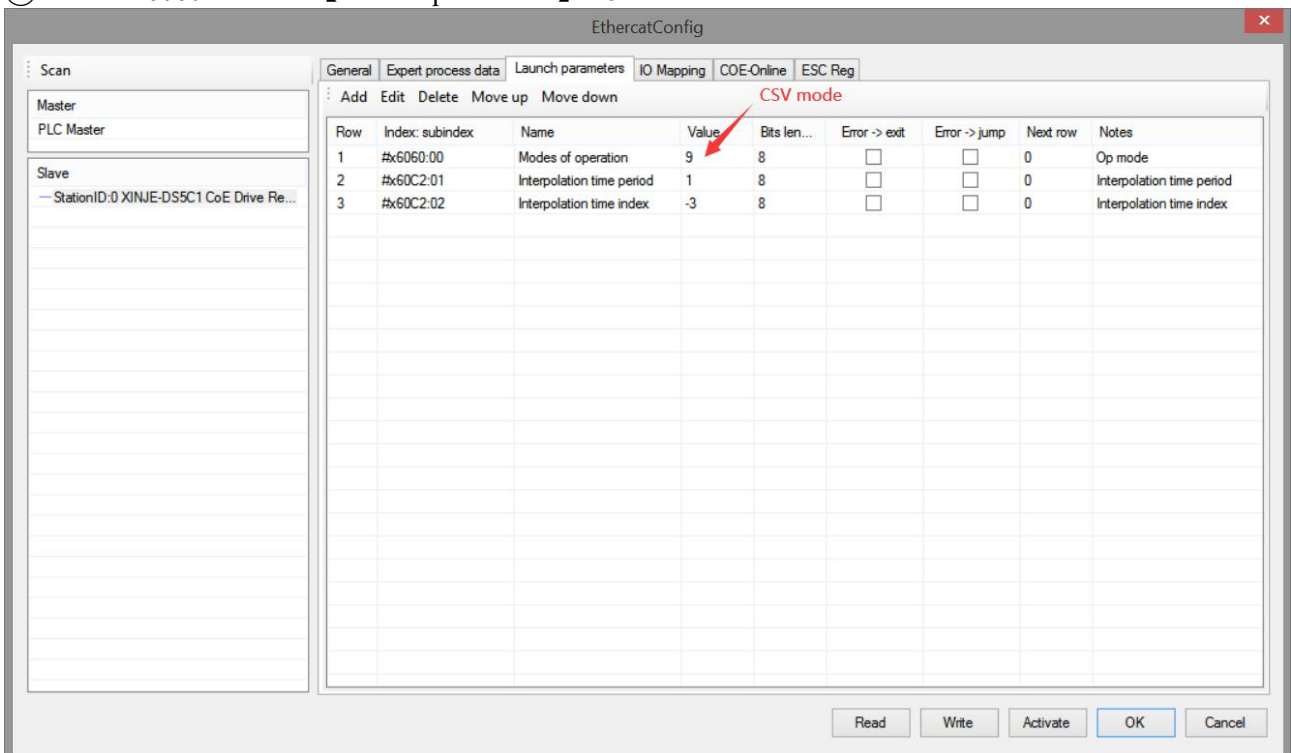

④ 【IO mapping】 default start address is HD10000, which can be changed if necessary.

⑤ After setting all the parameters, click 【write】 → 【activate】 → 【OK】 . The parameters will take effect after the activation is successful.

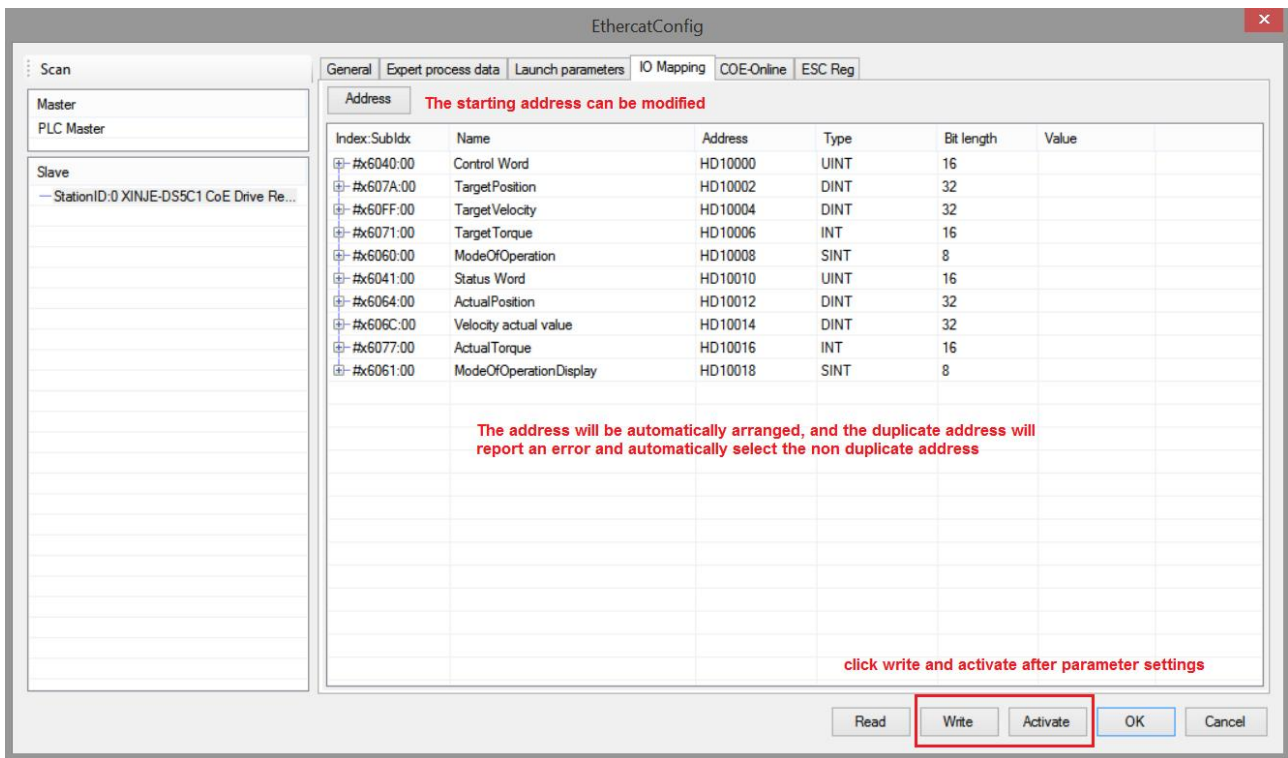

⑥ After the activation is completed, the slave station state machine (SD8021) will change state from 1 → 2 → 4 → 8, 8 means OP state. At this time, both SDO and PDO can receive and send messages. After the state is switched to OP, 6080h (maximum motor speed) can be modified through COE-Online.

⑦ After enabling ON, HD10000 (mapping of 6040h) will indicate the slave enable status from 6 → 7 → 15, which can be assigned a value to HD10004 (mapping of 60FFh) as the given speed in CSV mode (real-time speed interpolation can be achieved by modifying HD1004 in I9900 interrupt).

⑧ In CSV mode, the current given speed can be monitored through HD10004 (mapping of 60FFh), the current actual position of the motor can be monitored through HD10012 (mapping of 6064h), and the current actual speed can be monitored through HD10014 (mapping of 606Ch).

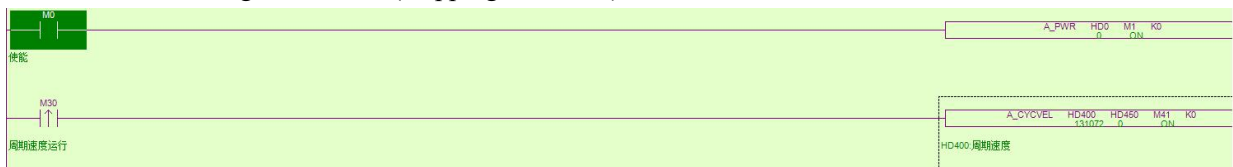

名称	监控值	类型	映射地址/字长	注释
M0	ON	BIT	位	使能
M30	OFF	BIT	位	周期速度运行
HD400	131072	LREAL	四字	周期速度
HD10002	43691646	DINT	双字	Station ID:0,#x607A:0,Target position
HD10004	131072	DINT	双字	Station ID:0,#x60FF:0,Target velocity
HD10008	9	INT	单字	Station ID:0,#x6060:0,Modes of operation
HD10014	130722	DINT	双字	Station ID:0,#x606C:0,Velocity actual value
HD10012	43691122	DINT	双字	Station ID:0,#x6064:0,Position actual value
SFD811	1	INT	单字	运动控制功能: 0-简单型; 1-入门实用型;

3) CST mode operation example

Register	Explanation	Unit
RXPDO[0x6071]	Target torque	0.1%
TXPDO[0x6064]	Position actual value	Command unit
TXPDO[0x606C]	Velocity actual value	Command unit/s
TXPDO[0x6077]	Torque actual value	0.1%
RXPDO[0x6080]	Max motor speed	r/min
RXPDO[0x6060]	Set to 10	-

① Click **scan** or **add** in the EtherCAT interface, **general** interface please use default settings.

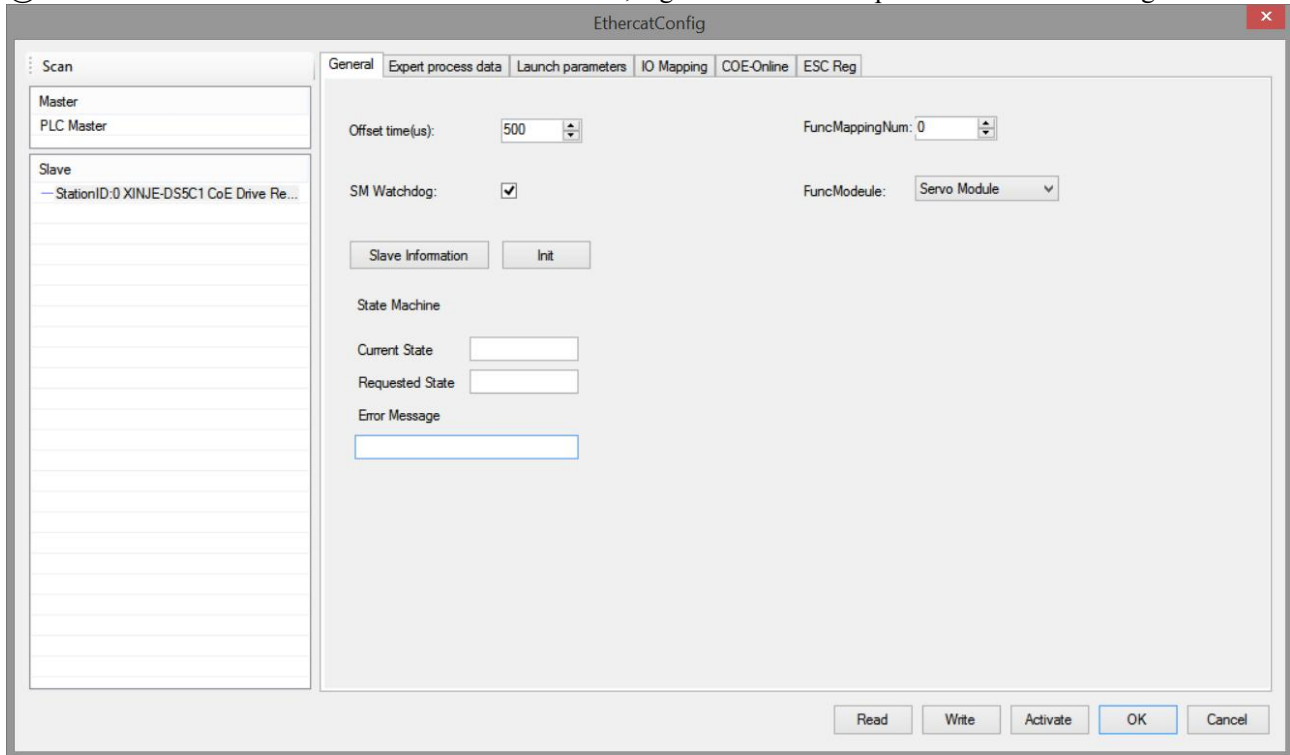

② Click **Expert process data** → **PDO list** , select 1600, 1A00. The default configuration can meet the basic use of CST. If necessary, other PDO parameters can be added. For example, add 6080h to modify max motor speed and limit the torque.

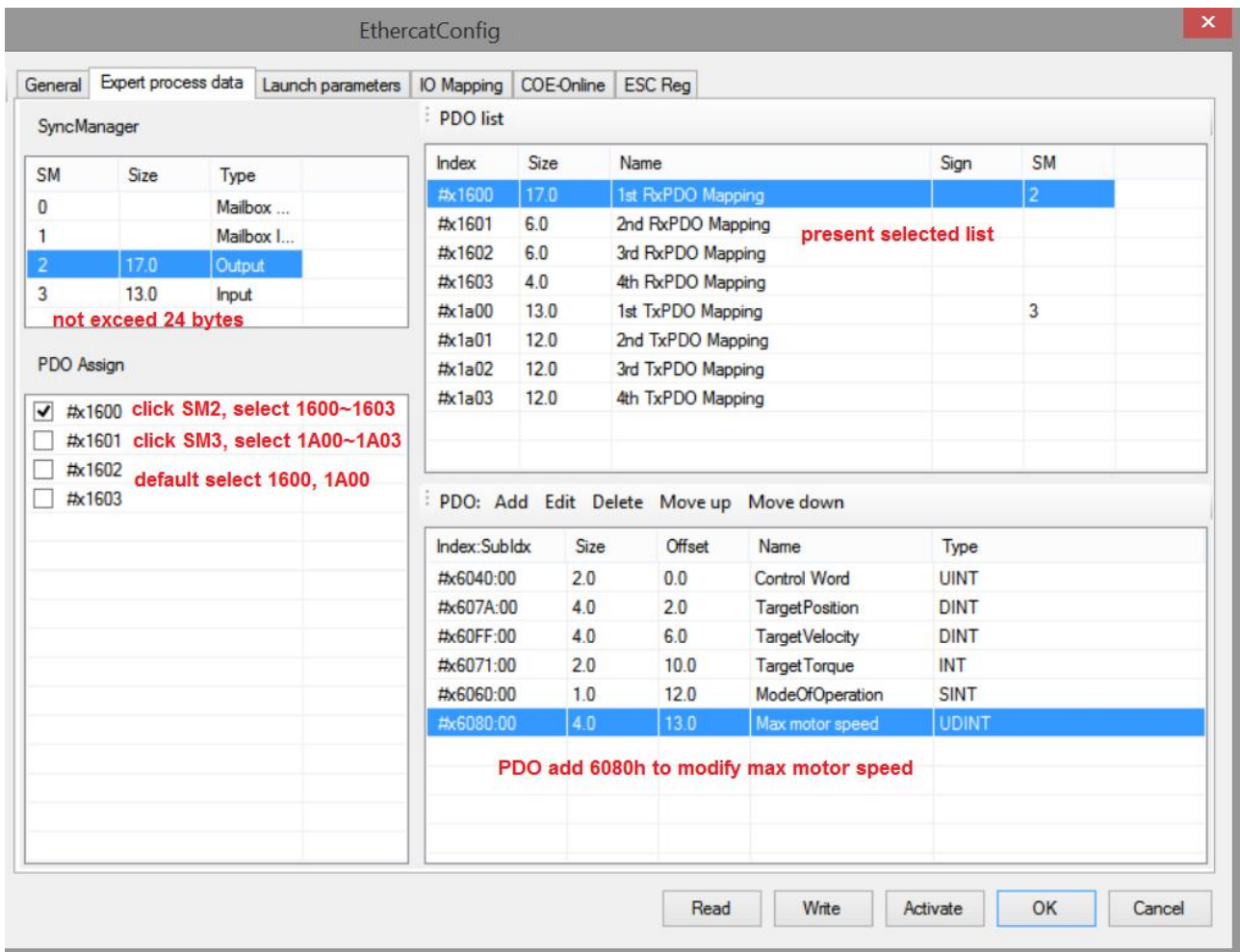

③ Confirm 6060h value in 【Launch parameters】 is 10.

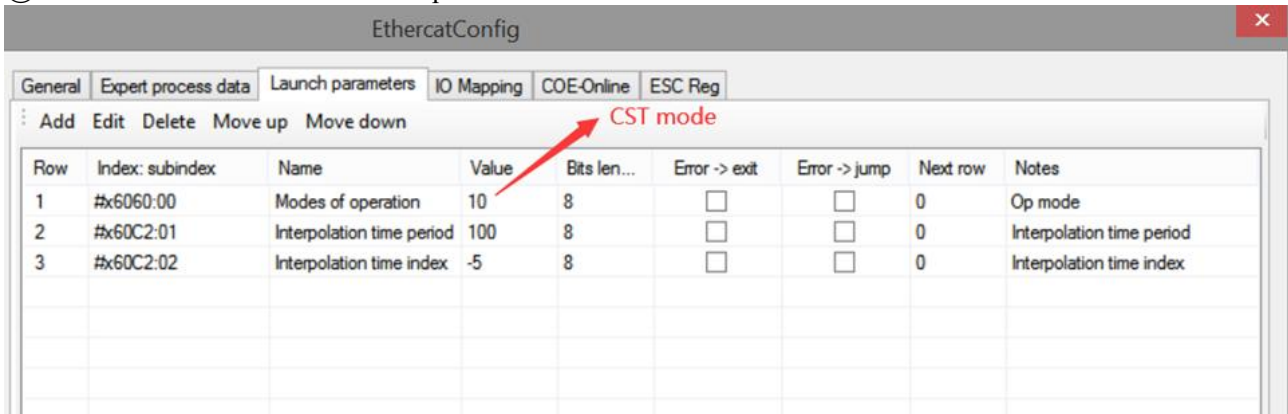

④ 【IO mapping】 default start address is HD10000, which can be changed if necessary.

⑤ After setting all the parameters, click 【write】 → 【activate】 → 【OK】 . The parameters will take effect after the activation is successful.

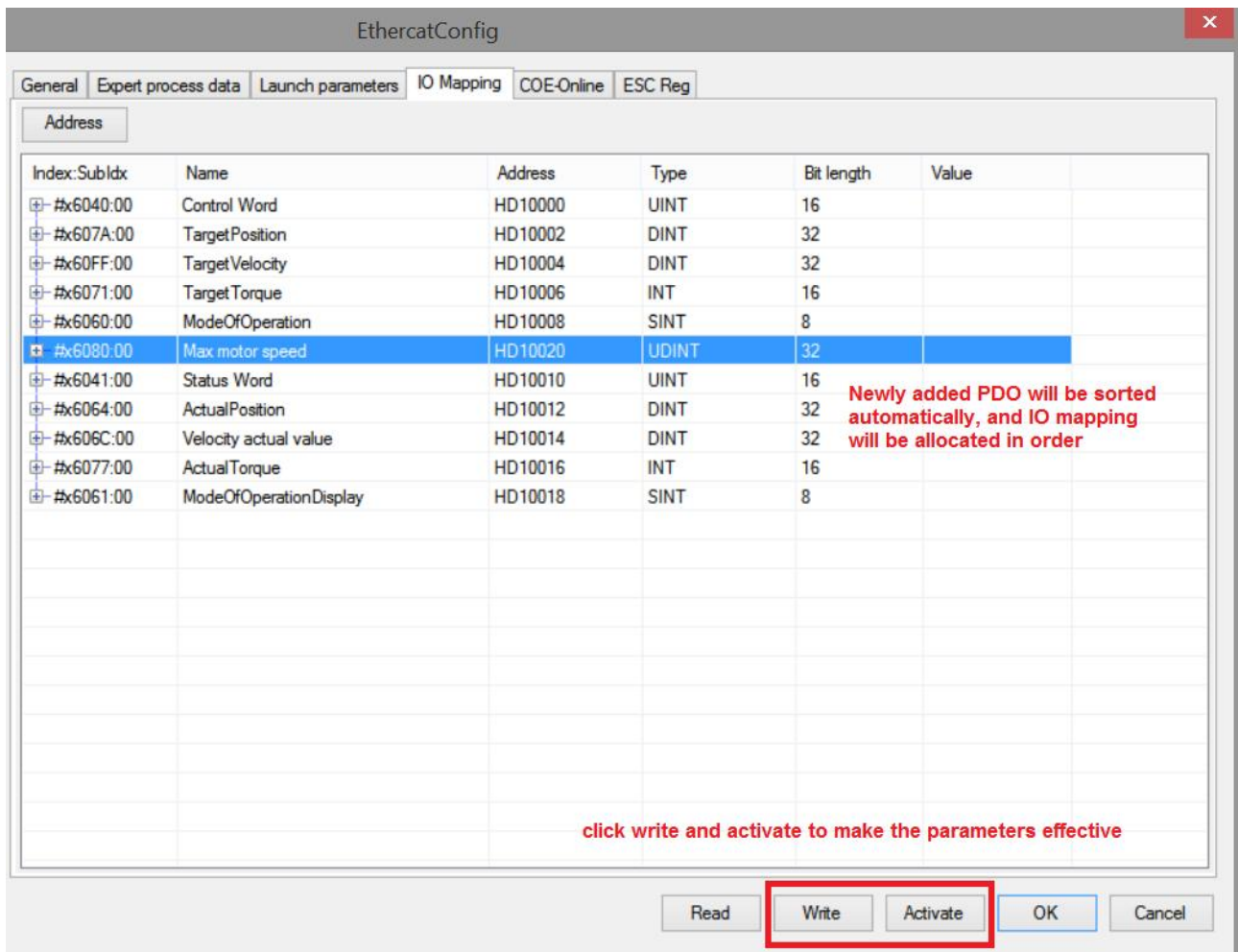

⑥ After the activation is completed, the slave station state machine (SD8021) will change state from 1 → 2 → 4 → 8, 8 means OP state. At this time, both SDO and PDO can receive and send messages.

⑦ After enabling ON, HD10000 (mapping for 6040h) will indicate the slave enable state from 6 → 7 → 15, which can be assigned a value to HD10006 (mapping for 6071h) as the given torque in CST mode.

⑧ In CST mode, the current given torque can be monitored through HD10006 (mapping of 6071h), the current actual position can be monitored through HD10012 (mapping of 6064h), the current actual speed can be monitored through HD10014 (mapping of 606Ch), the current actual torque can be monitored through HD10016 (mapping of 6077h), and the maximum motor speed can be limited through 6080h.

Note: After adding the speed limit parameter, ensure that the speed limit is within the appropriate range during operation.

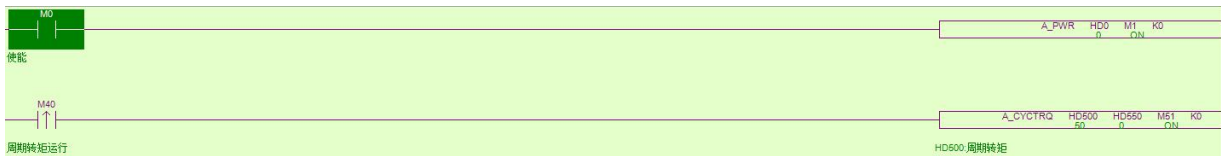

名称	监控值	类型	映射地址/字长	注释
M0	ON	BIT	位	使能
M40	OFF	BIT	位	周期转矩运行
HD500	50	LREAL	四字	周期转矩
HD10020	10	DINT	双字	Station ID:0,#x6080:0,Max motor speed
HD10002	3150984	DINT	双字	Station ID:0,#x607A:0,TargetPosition
HD10004	0	DINT	双字	Station ID:0,#x60FF:0,TargetVelocity
HD10008	10	INT	单字	Station ID:0,#x6060:0,ModeOfOperation
HD10014	21816	DINT	双字	Station ID:0,#x606C:0,Velocity actual value
HD10012	3150939	DINT	双字	Station ID:0,#x6064:0,ActualPosition
SFD811	1	INT	单字	运动控制功能: 0-简单型; 1-入门实用型;

4) HM mode operation example

HM control mode related objects

Register	Explanation	Unit
RXPDO[0x6040]	Control word, modify control word to enable homing	-
RXPDO[0x6098]	Homing mode	-
RXPDO[0x609A]	Homing acceleration speed	Command unit/s ²
RXPDO[0x6060]	The control mode is HM mode (i.e. homing mode), and its value is set to 6 when the motor is not enabled	-
SDO[0x6099]	Homing speed, modify online through COE-Online	Command unit/s

① Terminal assignment is performed. P5-22 is the positive limit setting address, and the default value is 1, related to servo terminal SI1. P5-23 is the setting address of the reverse limit, and the default value is 2, related to servo terminal SI2, P5-27 is the origin setting address, and the default value is 3, related to servo terminal SI3.

② Click **scan** or **add** in the EtherCAT interface, **general** interface please use default settings.

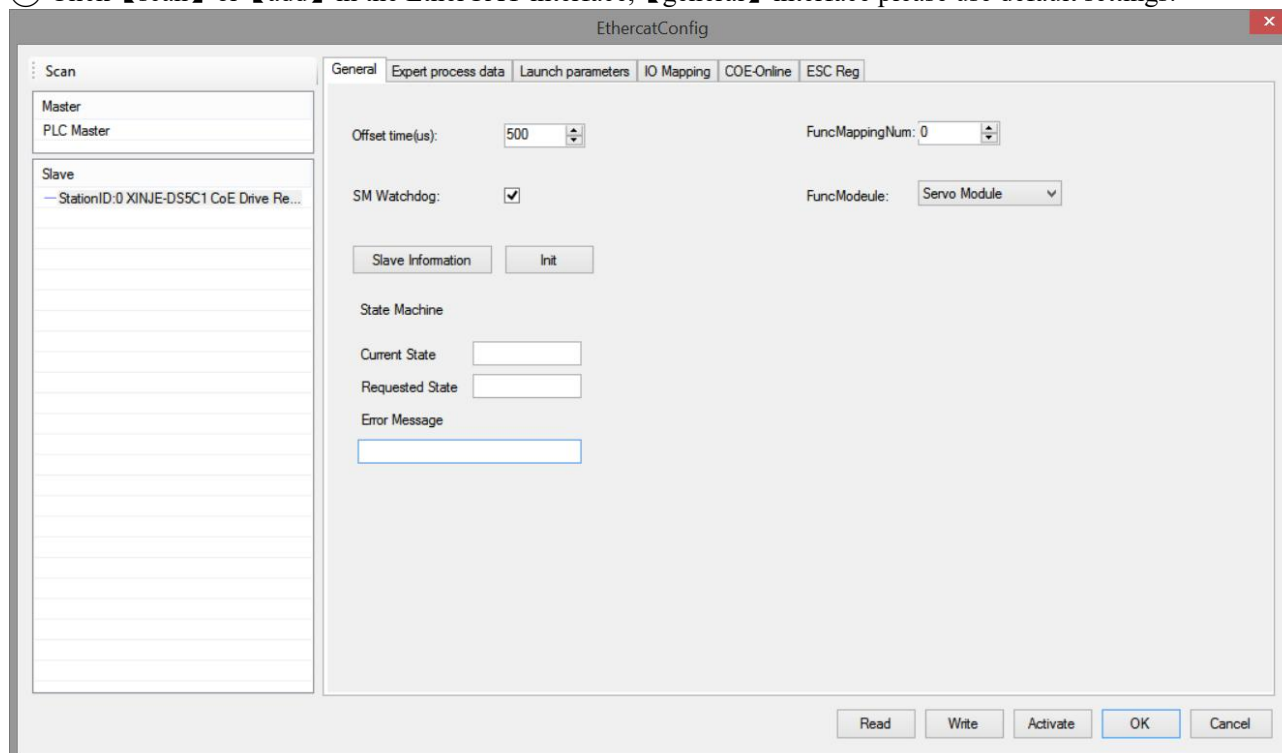

③ **Expert process data** → **PDO list** select 1600, 1A00, add 6098h in 1600.

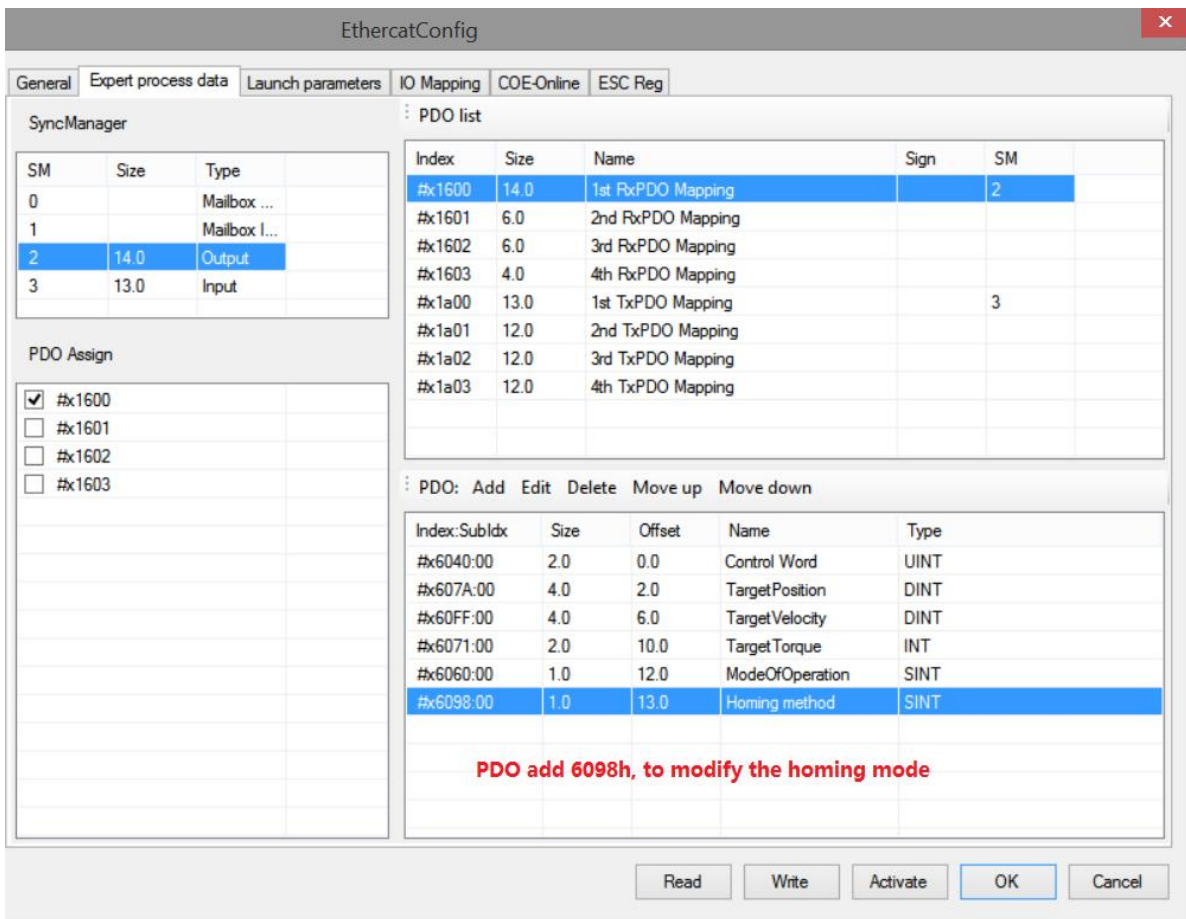

④ Confirm 6060h value in **【Launch parameters】** is 6.

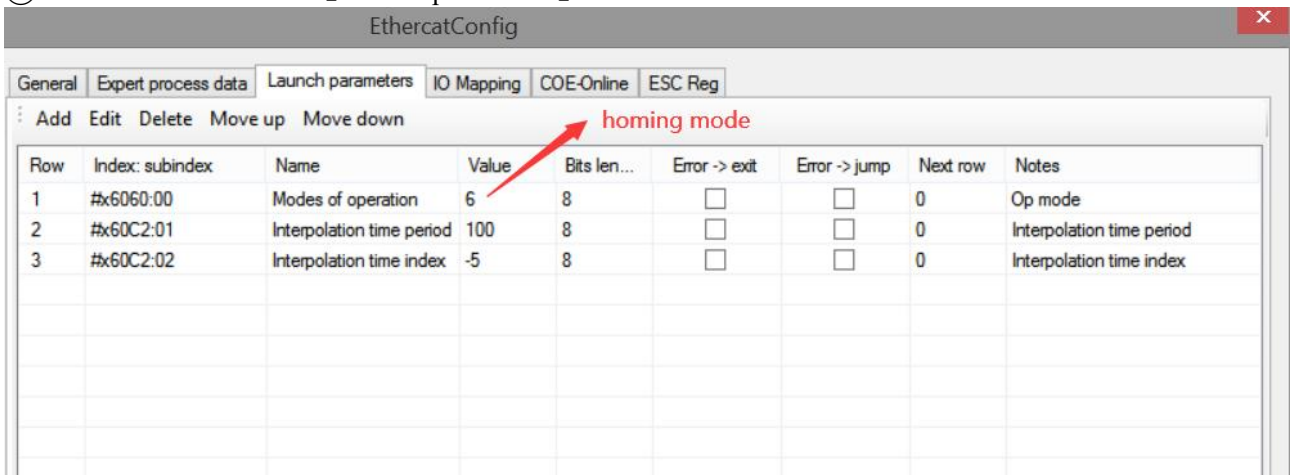

⑤ **【IO mapping】** default start address is HD10000, which can be changed if necessary.

⑥ After setting all the parameters, click **【write】** → **【activate】** → **【OK】** . The parameters will take effect after the activation is successful.

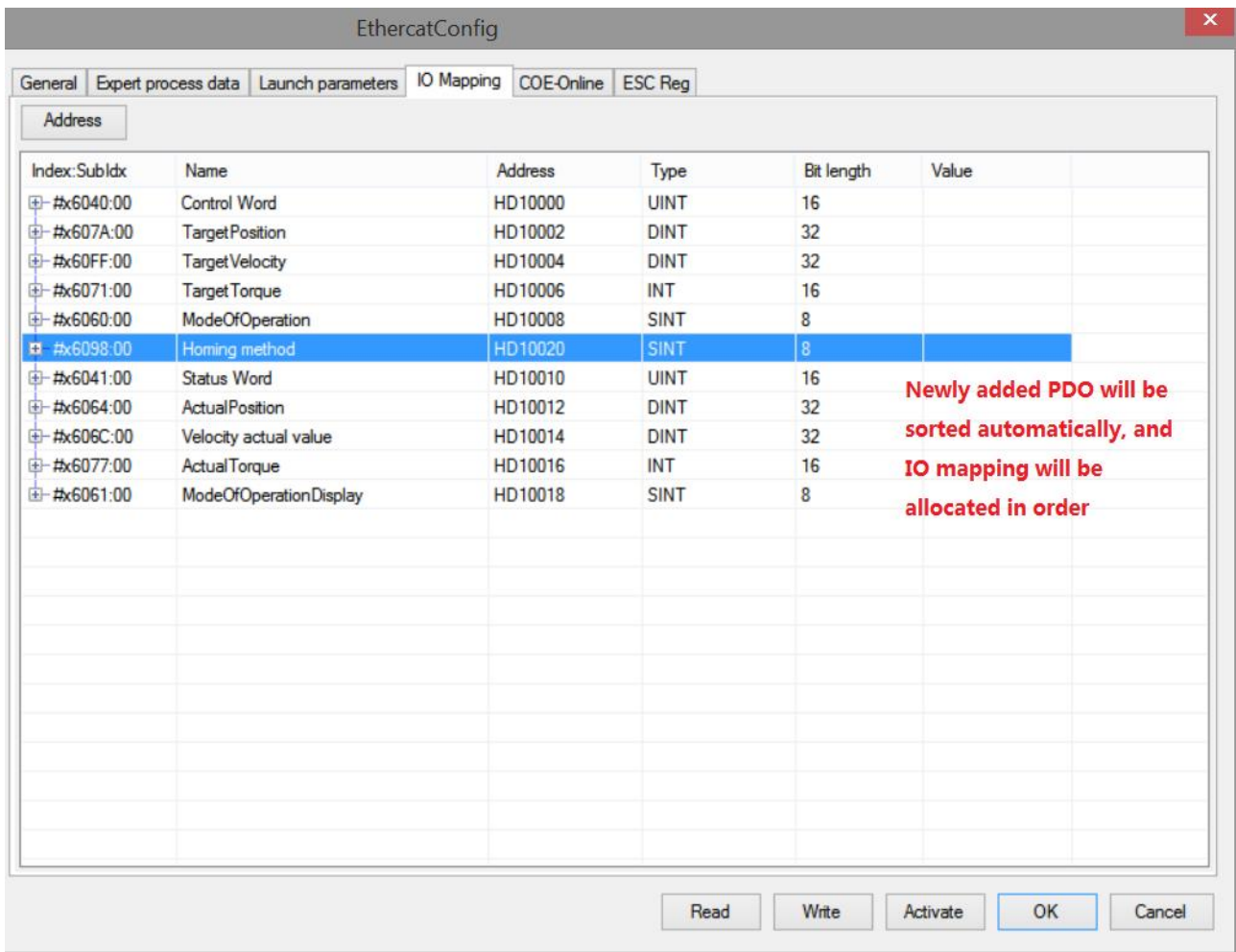

⑦ After the activation is completed, the slave station state machine (SD8021) will be from 1 → 2 → 4 → 8, 8 means OP status. At this time, both SDO and PDO can receive and send messages.

⑧ After the state is switched to OP, the homing speed and acceleration can be modified through COE-Online.

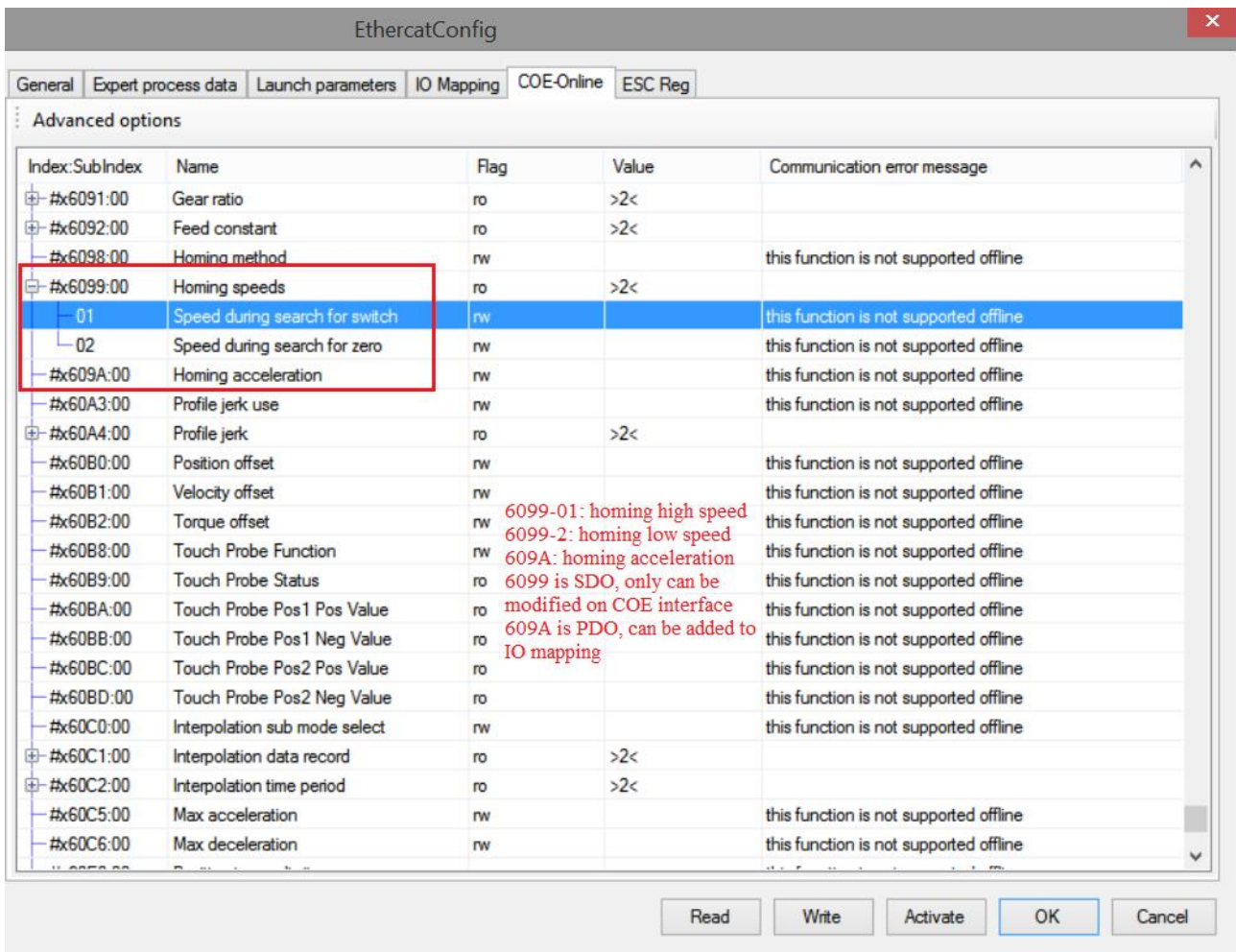

⑨ Set the homing mode (6098h).

This setting range is 1-37 (currently supports methods 1-14, 17-30, 33, 34, 35, 37) (versions before 3791).

This setting range is -2~37 (currently supports methods -2~14, 17~30, 33, 34, 35, 37) (3791 and later versions).

⑩ After enabling ON, HD10000 (6040h mapping) will go from 6 → 7 → 15 to indicate the slave station's enabled state, and then HD10000 (6040h mapping) will go from 15 → 31 to enable the homing. During the homing process, if the origin signal is triggered, it will slow down and stop according to the corresponding way of homing. To homing again, first change 6040h to 15, and then HD10000 (mapping of 6040h) 15 → 31.

5) PP mode operation example

PP control mode related object (command · setting)

Register	Explanation	Unit
RXPDO[0x6040]	Control word	-
RXPDO[0x6060]	Set to 1	-
RXPDO[0x607A]	Target position	Command unit
RXPDO[0x6072]	Max torque	0.1%
RXPDO[0x607F]	Max Profile velocity	Command unit/s
RXPDO[0x6080]	Max motor speed	r/min
RXPDO[0x6081]	Profile velocity	Command unit/s
RXPDO[0x6083]	Profile acceleration	Command unit/s ²
RXPDO[0x6084]	Profile deceleration	Command unit/s ²
RXPDO[0x60C5]	Max acceleration	Command unit/s ²
RXPDO[0x60C6]	Max deceleration	Command unit/s ²
RXPDO[0x6065]	Following error window	Command unit
RXPDO[0x6066]	Following error time out	ms
RXPDO[0x6067]	Position windows	Command unit
RXPDO[0x6068]	Position window time	ms

Note:

- (1) 6081h (profile speed) is limited by the smaller one of 607Fh (maximum internal speed) and 6080h (maximum motor speed).
- (2) Changing the set value of 607Fh (maximum internal speed) or 6080h (maximum motor speed) during the operation is not reflected in the operation.

pp control mode related object (command · monitor)

Register	Explanation	Unit
TXPDO[0x6041]	Status word	-
TXPDO[0x6063]	Position actual internal value	Command unit
TXPDO[0x6064]	Position actual value	Command unit
TXPDO[0x606C]	Speed feedback	Command unit /s
TXPDO[0x6077]	Actual torque	0.1%
TXPDO[0x60F4]	Following error actual value	Command unit

- ① Click **【scan】** or **【add】** in the EtherCAT interface, function module please set to user define in **【general】** interface.

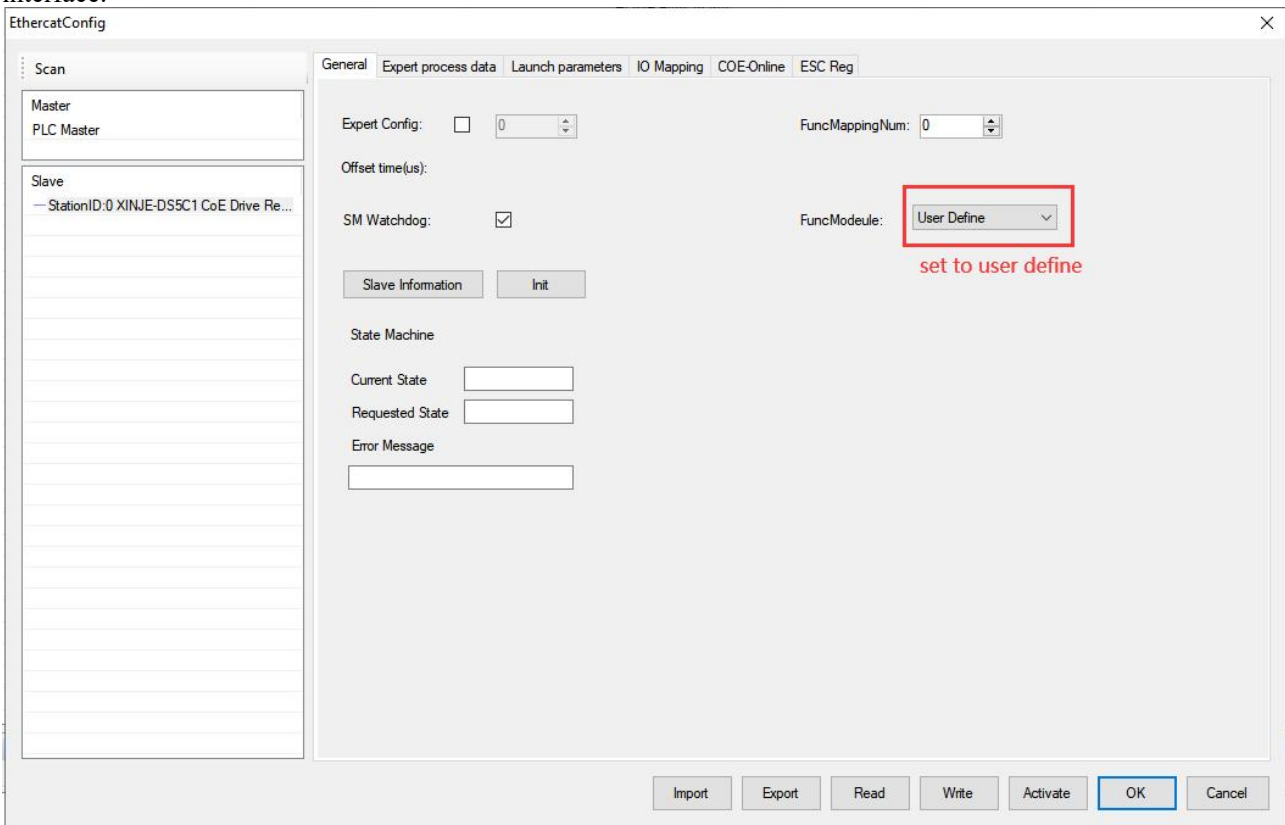

- ② Click **【Expert process data】** → **【PDO list】**, select 1600, 1A00. PDO parameters associated with the mode can be added (1600 and 1A00 can not add more than 32 bytes respectively).

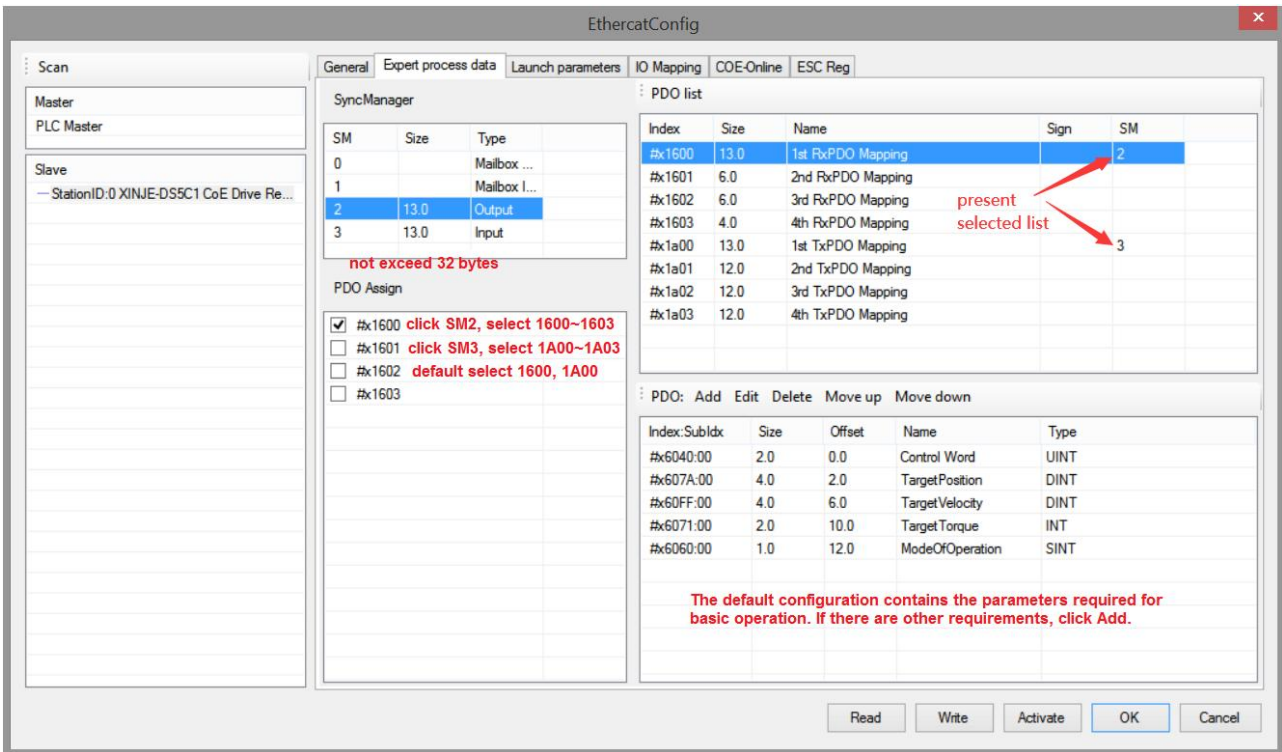

③ Confirm 6060h value 【launch parameters】 is 1.

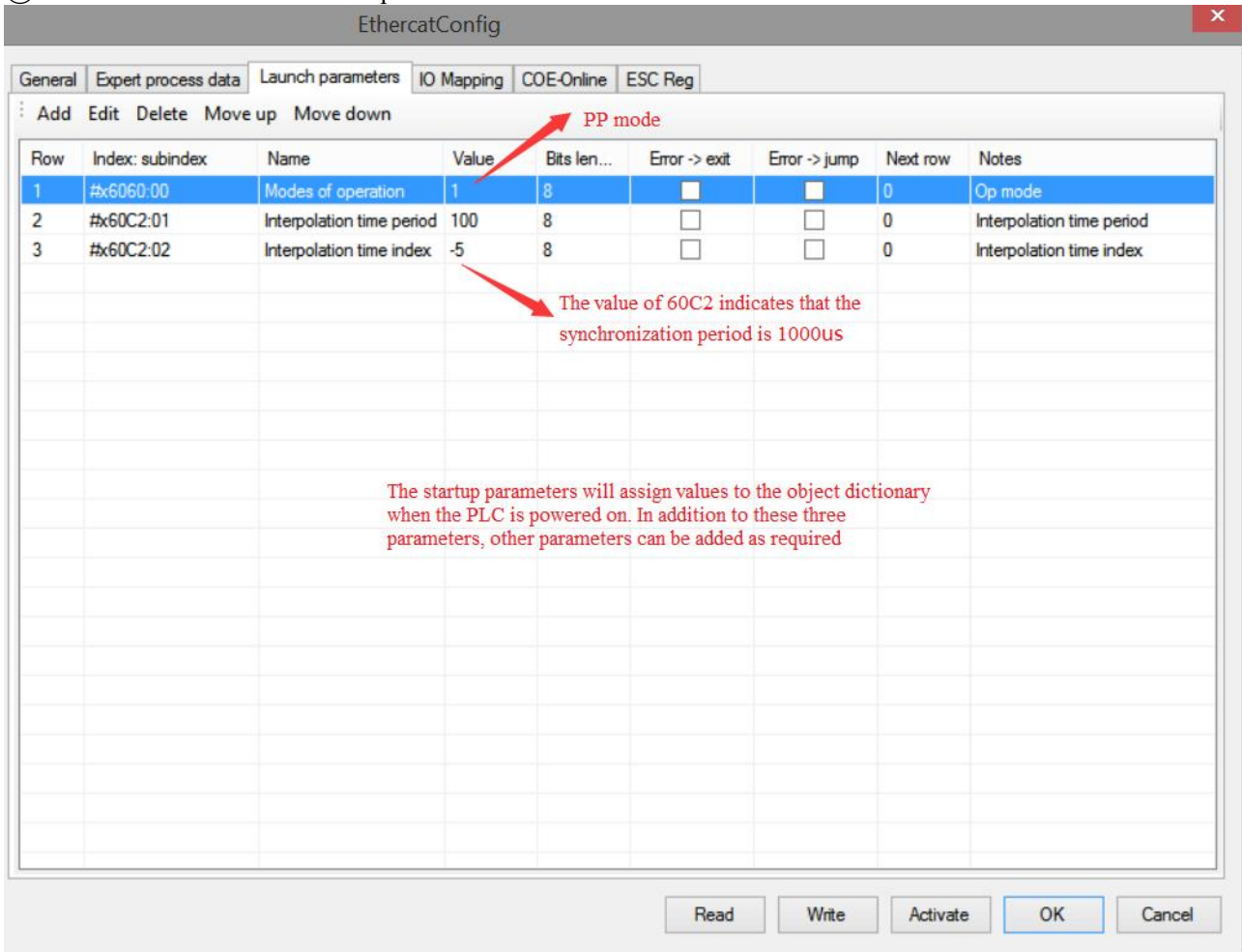

④ 【IO mapping】 default start address is HD10000, which can be changed if necessary.

⑤ After parameter configuration is completed, click **【write】** → **【activate】** → **【OK】** . After activation, the parameters will take effect.

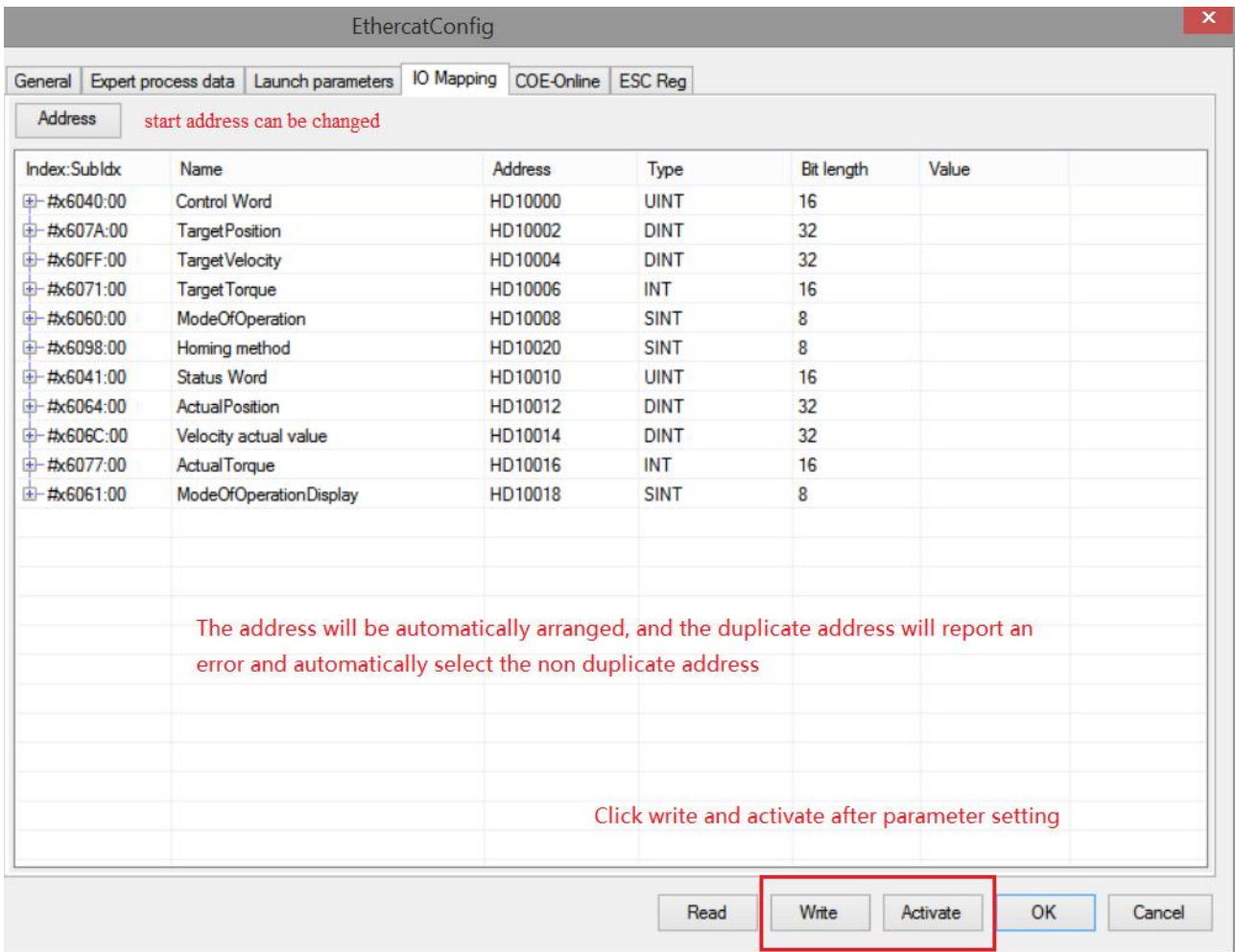

⑥ After the activation is completed, the slave station state machine (SD8021) will from 1 → 2 → 4 → 8, 8 means OP status. At this time, both SDO and PDO can receive and send messages.

⑦ Modify the control word 6040 (absolute mode: 6 → 15 → 31, relative mode: 6 → 79 → 95) to enable the slave station to move the motor by setting the target position, target speed, acceleration and deceleration and other parameters.

⑧ In PP mode, data can be monitored through I/O mapping address setting. For example, the control word of axis 1 can be modified through HD10000 (mapping of 6040h), the motor can be enabled or disabled, and the given position of current axis 1 can be monitored through HD10004 (mapping of 607Ah).

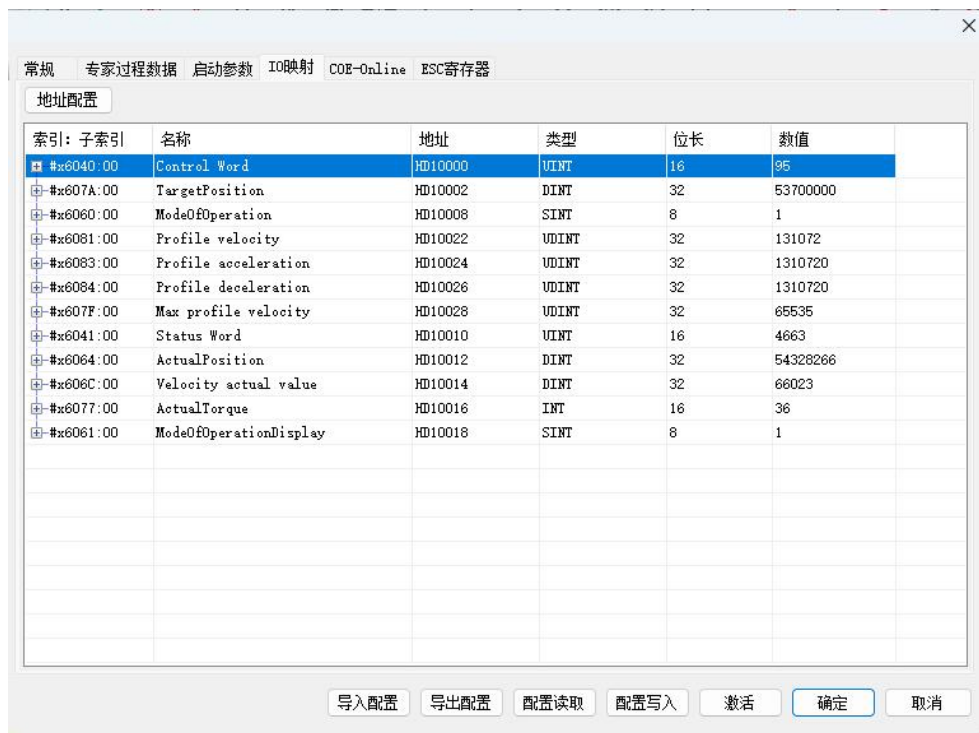

PLC1-自由监控1

监控窗口 ▾ | 添加 修改 删除 全部删除 | 上移 下移 置顶 置底

名称	监控值	类型	映射地址字长	注释
HD10000	95	INT	单字	Station ID:0,#x6040:0,Control ...
HD10002	53700000	DINT	双字	Station ID:0,#x607A:0,Target...
HD10014	65003	DINT	双字	Station ID:0,#x606C:0,Velocit...

6) PV mode operation example

pv control mode related object (command · setting)

Register	Explanation	Unit
RXPDO[0x6040]	Control word	-
RXPDO[0x6060]	Set to 3	-
RXPDO[0x60FF]	Target velocity	Command unit/s
RXPDO[0x6072]	Max torque	0.1%
RXPDO[0x607F]	Max Profile velocity	Command unit /s
RXPDO[0x6080]	Max motor speed	r/min
RXPDO[0x6083]	Profile acceleration	Command unit /s ²
RXPDO[0x6084]	Profile deceleration	Command unit /s ²
RXPDO[0x60C5]	Max acceleration	Command unit /s ²
RXPDO[0x60C6]	Max deceleration	Command unit /s ²
RXPDO[0x606D]	Velocity window	Command unit /s
RXPDO[0x606E]	Velocity window time	ms
RXPDO[0x606F]	Velocity threshold	Command unit /s
RXPDO[0x6070]	Velocity threshold time	ms

pv control mode related object (command · monitor)

Register	Explanation	Unit
TXPDO[0x6041]	Status word	-
TXPDO[0x6064]	Position actual value	Command unit
TXPDO[0x606C]	Velocity actual value	Command unit /s
TXPDO[0x6077]	Torque actual value	0.1%

① Click **【scan】** or **【add】** in the EtherCAT interface, function module please set to user define in **【general】** interface.

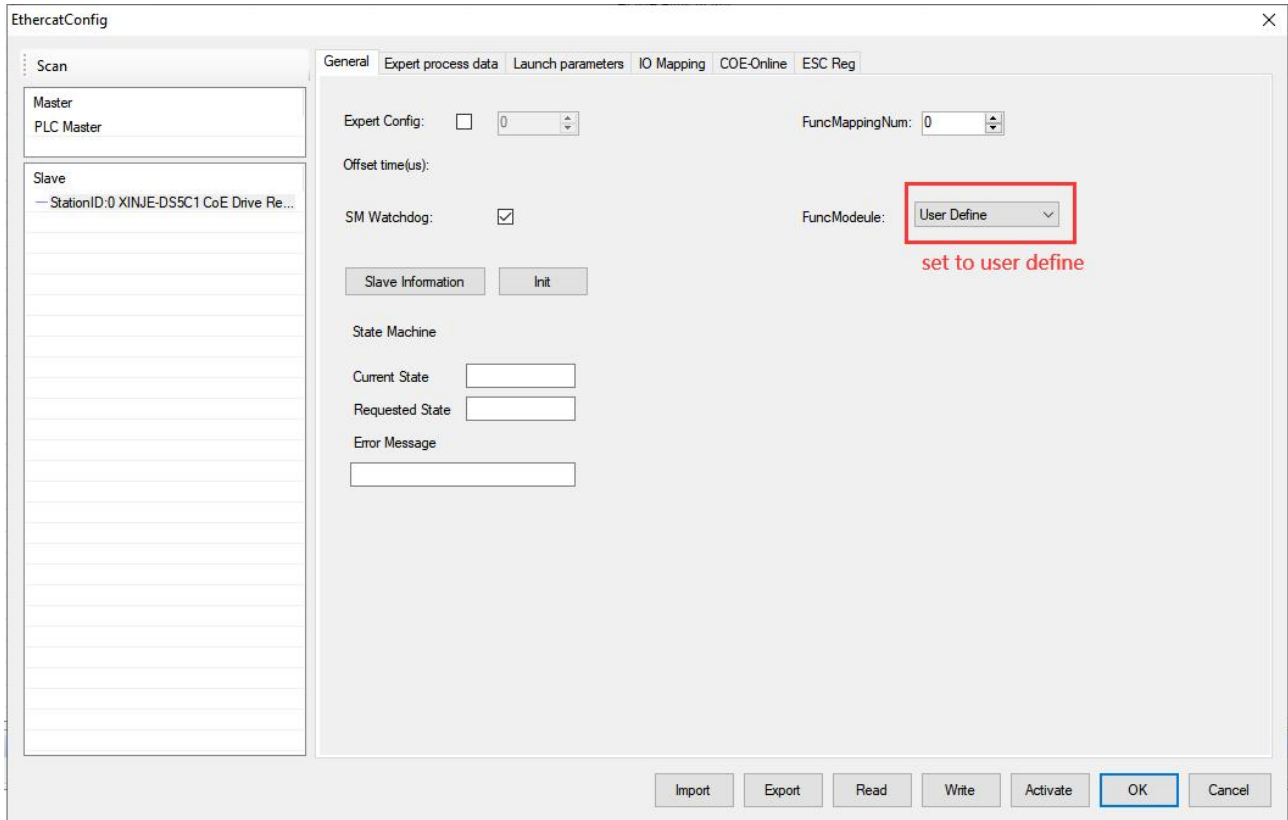

② Click **【Expert process data】** → **【PDO list】**, select 1600, 1A00. PDO parameters associated with the mode can be added (1600 and 1A00 can not add more than 32 bytes respectively)

EthercatConfig

General Expert process data Launch parameters IO Mapping COE-Online ESC Reg

SyncManager

SM	Size	Type
0		Mailbox ...
1		Mailbox I...
2	22.0	Output
3	13.0	Input

not exceed 32 bytes

PDO Assign

#x1600
 #x1601
 #x1602
 #x1603

PDO list

Index	Size	Name	Sign	SM
#x1600	22.0	1st RxPDO Mapping		2
#x1601	6.0	2nd RxPDO Mapping		
#x1602	6.0	3rd RxPDO Mapping		
#x1603	4.0	4th RxPDO Mapping		
#x1a00	13.0	1st TxPDO Mapping		3
#x1a01	12.0	2nd TxPDO Mapping		
#x1a02	12.0	3rd TxPDO Mapping		
#x1a03	12.0	4th TxPDO Mapping		

present selected list

PDO: Add Edit Delete Move up Move down

Index:SubIdx	Size	Offset	Name	Type
#x6040:00	2.0	0.0	Control Word	UINT
#x607A:00	4.0	2.0	TargetPosition	DINT
#x60FF:00	4.0	6.0	TargetVelocity	DINT
#x6060:00	1.0	10.0	ModeOfOperation	SINT
#x6098:00	1.0	11.0	Homing method	SINT
#x6072:00	2.0	12.0	Max torque	UINT
#x6080:00	4.0	14.0	Max motor speed	UDINT
#x607F:00	4.0	18.0	Max profile velocity	UDINT

In addition to the default configuration, add other parameters as required

Read Write Activate OK Cancel

③ Confirm the 6060h value in 【Lanuch parameter】 is 3.

EthercatConfig

General Expert process data Launch parameters IO Mapping COE-Online ESC Reg

Add Edit Delete Move up Move down

Row	Index: subindex	Name	Value	Bits len...	Error -> exit	Error -> jump	Next row	Notes
1	#x6060:00	Modes of operation	3	8	<input type="checkbox"/>	<input type="checkbox"/>	0	Op mode
2	#x60C2:01	Interpolation time period	100	8	<input type="checkbox"/>	<input type="checkbox"/>	0	Interpolation time period
3	#x60C2:02	Interpolation time index	-5	8	<input type="checkbox"/>	<input type="checkbox"/>	0	Interpolation time index

PV mode

The value of 60C2 indicates that the synchronization period is 1000us

The startup parameters will be assigned to the object dictionary when the PLC is powered on. In addition to these three default parameters, other parameters will be added as required

Read Write Activate OK Cancel

- ④ 【IO mapping】 The starting address can be customized and modified.
- ⑤ After configuring the parameters, click 【write】 → 【activate】 → 【OK】 , the parameters will take effect after the activation is successful.

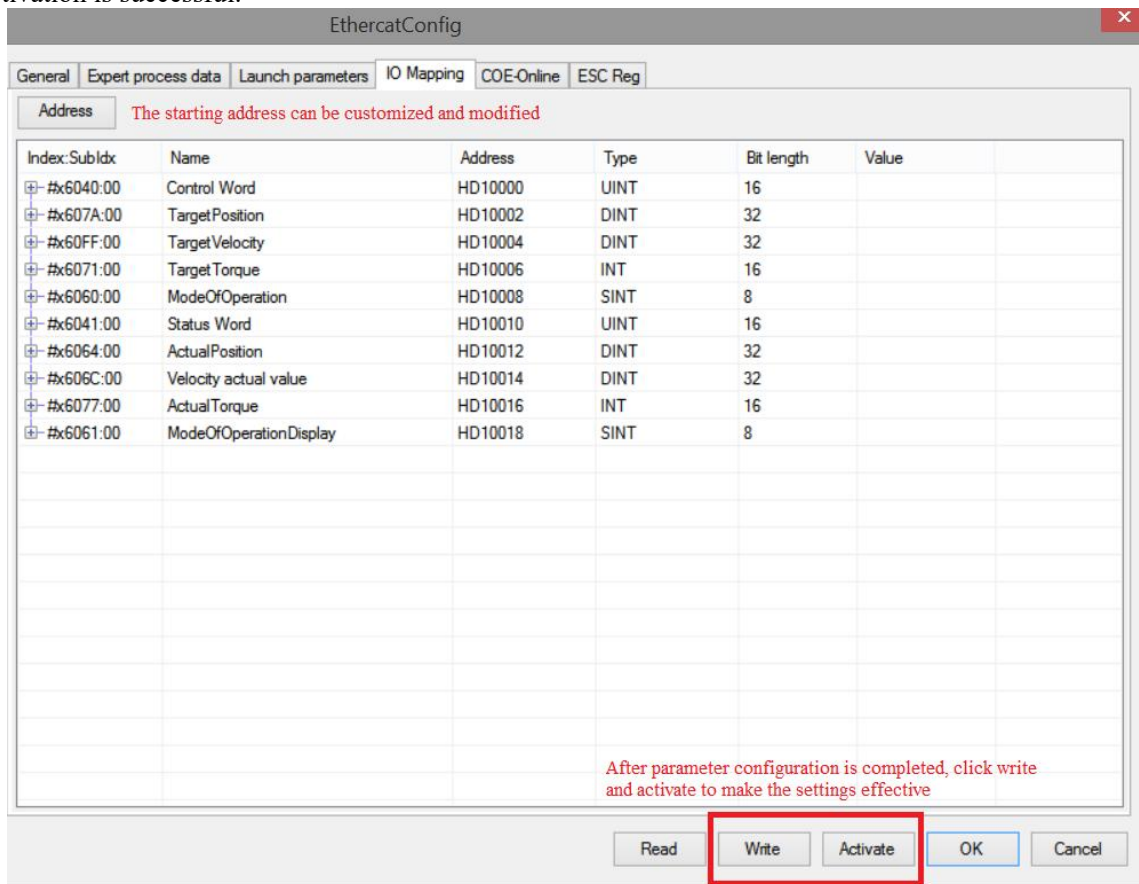

- ⑥ After the activation is completed, the slave station state machine (SD8021) will from 1 → 2 → 4 → 8, 8 means the OP status. At this time, SDO and PDO can receive and send messages
- ⑦ Modify the control word 6040 (6 → 15) to enable the slave station and move the motor by setting the target speed, acceleration and deceleration and other parameters
- ⑧ In PV mode, data can be set and monitored through I/O mapping addresses. For example, the control word of axis 1 can be modified through HD10000 (6040h mapping) to enable or disable the motor. The actual position of the current motor on axis 1 can be monitored through HD10012 (6064h mapping), and the actual speed of axis 1 can be monitored through HD10014 (606Ch mapping).

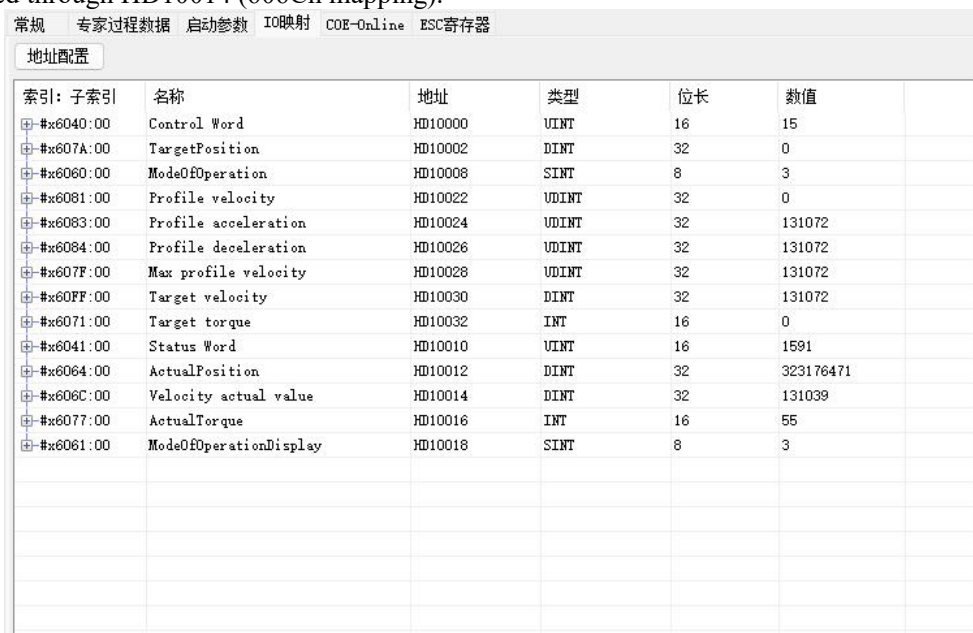

PLC1-自由监控1				
监控窗口 ▾ 添加 修改 删除 全部删除 上移 下移 置顶 置底				
名称	监控值	类型	映射地址字长	注释
HD10000	15	INT	单字	Station ID:0,#x6040:0,Control ...
HD10012	315360395	DINT	双字	Station ID:0,#x6064:0,Actual...
HD10014	130324	DINT	双字	Station ID:0,#x606C:0,Velocit...

7) TQ mode operation example

TQ control mode related objects (command · setting)

Register	Note	Unit
RXPDO[0x6040]	Control word	-
RXPDO[0x6060]	Control mode is tq (Profile torque control mode), set its value to 4	-
RXPDO[0x6071]	Target torque given	0.1%
RXPDO[0x6072]	Max torque	0.1%
RXPDO[0x6080]	Maximum motor speed	r/min
RXPDO[0x6087]	Set torque slope	0.1%/S
RXPDO[0x6088]	Set the type of torque profile to use	-

TQ control mode related objects (command · monitoring)

Register	Note	Unit
TXPDO[0x6041]	Status word	-
TXPDO[0x6064]	Position feedback (actual motor position)	Command unit
TXPDO[0x606C]	Speed feedback	Command unit /s
TXPDO[0x6077]	Actual torque	0.1%

- Click **【scan】** or **【add】** slave on EtherCATconfig interface, function module please set to user define in **【general】** interface.

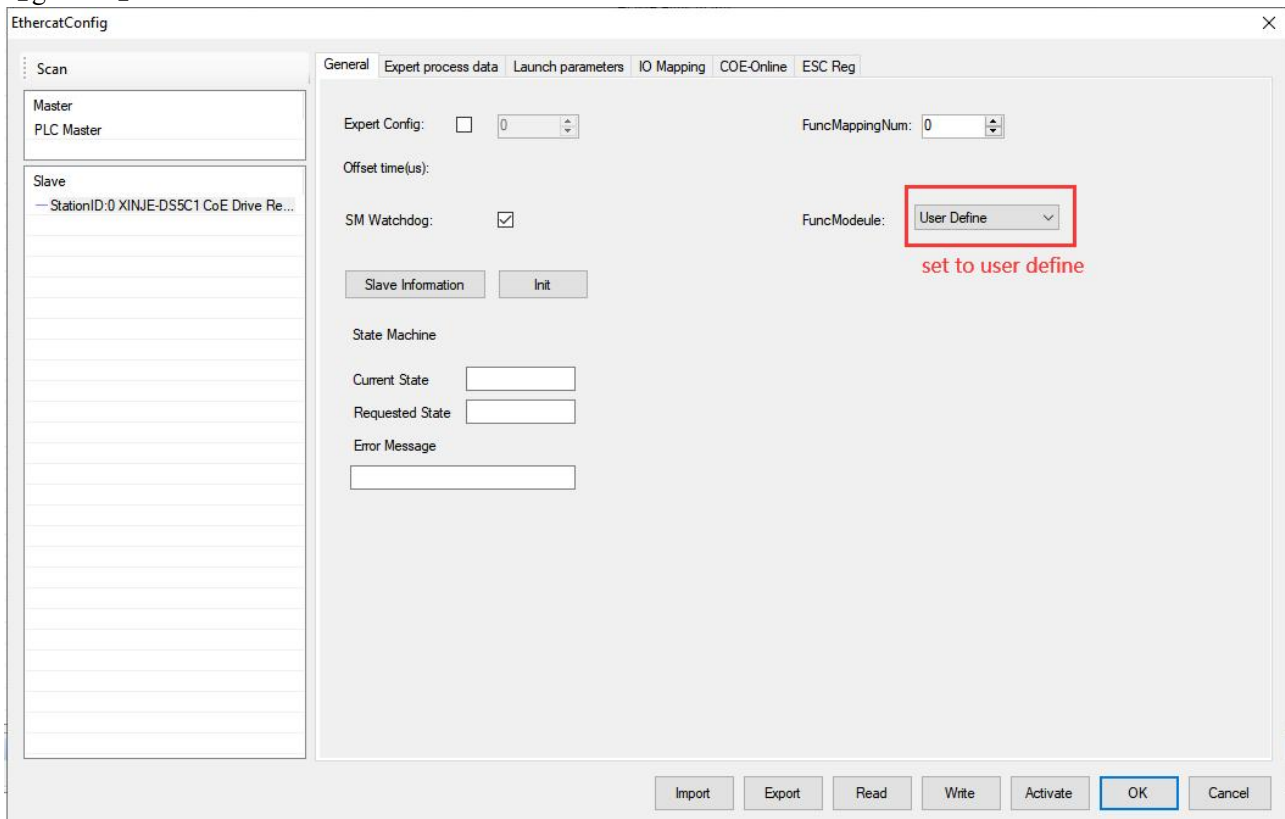

② Select 1600, 1A00 in **【expert process data】** → **【PDO list】**, PDO parameters associated with the mode can be added (1600 and 1A00 cannot add more than 32 bytes respectively).

SyncManager

SM	Size	Type
0		Mailbox ...
1		Mailbox I...
2	22.0	Output
3	13.0	Input

not exceed 32 bytes

PDO Assign

#x1600
 #x1601
 #x1602
 #x1603

PDO list

Index	Size	Name	Sign	SM
#x1600	22.0	1st RxPDO Mapping		2
#x1601	6.0	2nd RxPDO Mapping		
#x1602	6.0	3rd RxPDO Mapping		
#x1603	4.0	4th RxPDO Mapping		
#x1a00	13.0	1st TxPDO Mapping		
#x1a01	12.0	2nd TxPDO Mapping		
#x1a02	12.0	3rd TxPDO Mapping		
#x1a03	12.0	4th TxPDO Mapping		

present selected list

PDO: Add Edit Delete Move up Move down

Index:SubIdx	Size	Offset	Name	Type
#x6040:00	2.0	0.0	Control Word	UINT
#x607A:00	4.0	2.0	TargetPosition	DINT
#x60FF:00	4.0	6.0	TargetVelocity	DINT
#x6060:00	1.0	10.0	ModeOfOperation	SINT
#x6098:00	1.0	11.0	Homing method	SINT
#x6072:00	2.0	12.0	Max torque	UINT
#x6080:00	4.0	14.0	Max motor speed	UDINT
#x607F:00	4.0	18.0	Max profile velocity	UDINT

In addition to the default configuration, add other parameters as required

Read Write Activate **OK** Cancel

③ Confirm 6060h value in **【Launch parameter】** is 4.

Launch parameters

Add Edit Delete Move up Move down

Row	Index: subindex	Name	Value	Bits len...	Error -> exit	Error -> jump	Next row	Notes
1	#x6060:00	Modes of operation	4	8	<input type="checkbox"/>	<input type="checkbox"/>	0	Op mode
2	#x60C2:01	Interpolation time period	1	8	<input type="checkbox"/>	<input type="checkbox"/>	0	Interpolation time period
3	#x60C2:02	Interpolation time index	-3	8	<input type="checkbox"/>	<input type="checkbox"/>	0	Interpolation time index

TQ mode

60C2: Synchronization period: 1000us

The startup parameters will assign values to the object dictionary when the PLC is powered on. In addition to these three default parameters, other parameters can be added as required

④ **【IO mapping】** the starting address can be customized and modified.

⑤ After configuring the parameters, click **【write】** → **【activate】** → **【OK】**, the parameters will take effect after the activation is successful.

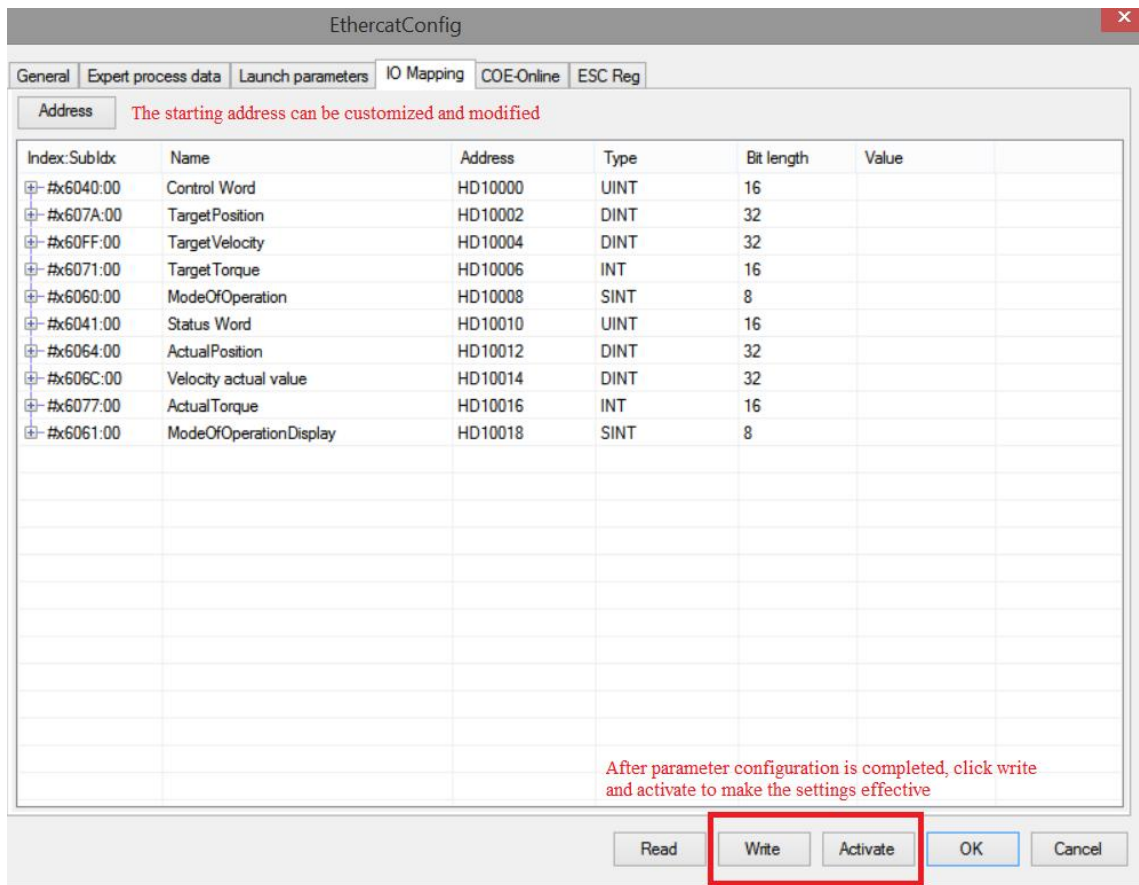

⑥ After activation, the slave station state machine (SD8021) will change from 1 → 2 → 4 → 8, 8 indicating the OP state. At this time, both SDO and PDO can receive and send messages.

⑦ Modify the control word 6040 (6 → 15) to enable the slave station to move the motor by setting the target torque, torque slope and other parameters.

⑧ In TQ mode, data can be set and monitored through I/O mapping addresses. For example, the control word of axis 1 can be modified through HD10000 (6040h mapping) to enable or disable the motor. The actual torque of the current motor on axis 1 can be monitored through HD10016 (6077h mapping), and the torque slope of axis 1 can be set through HD10038 (6087h mapping).

名称	监控值	类型	映射地...	注释
HD10000	15	INT	单字	Station ID:0,#x6040:0,Control Word
HD10016	41	INT	单字	Station ID:0,#x6077:0,ActualTorque
HD10038	50	UDINT	双字	Station ID:0,#x6087:0,Torque slope
HD10012	38084204	DINT	双字	Station ID:0,#x6064:0,ActualPosition
HD10014	132188	DINT	双字	Station ID:0,#x606C:0,Velocity actual ...

8) Probe function example (take DS5C1-20P4-PTA as an example)

Probe function related object

Index	Sub index	Name	Unit
60B8h	00h	Probe function settings	-
60B9h	00h	Indicates the status of the Touch probe function	-
60BAh	00h	Indicates the clamping position of the rising edge of Touch probe1	Command unit
60BBh	00h	Indicates the clamping position of the falling edge of Touch probe1	Command unit
60BCh	00h	Indicates the clamping position of the rising edge of Touch probe2	Command unit
60BDh	00h	Indicates the clamping position of the falling edge of Touch probe2	Command unit

- ① External wiring and probe terminal assignment: P5-62 and P5-63 are used for terminal assignment of probe function, probe 1 is assigned to SI1, probe 2 is assigned to SI2, 1 is written in P5-62 when SI1 is assigned, and 2 is written in P5-63 when SI2 is assigned.
- ② Click **scan** or **add** slave on EtherCATconfig interface, use default settings for **general** interface.

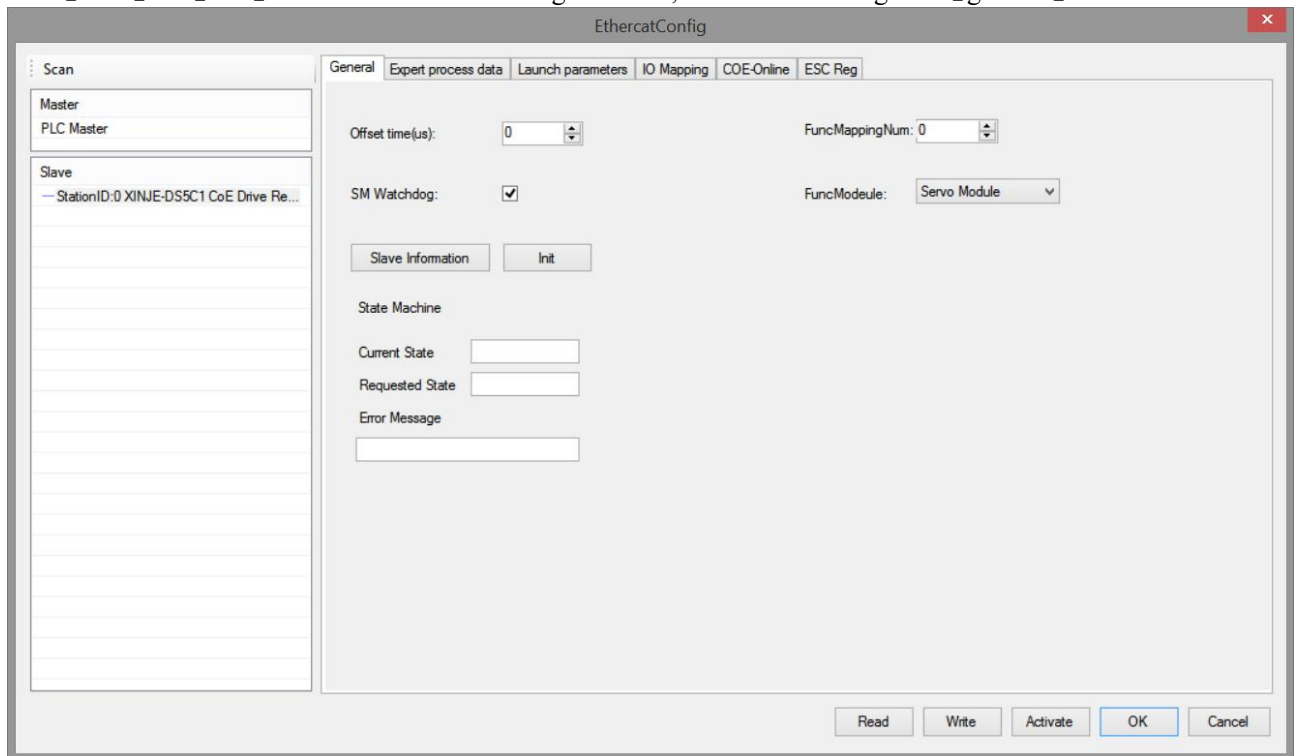

- ③ When the level signal connected to the driver SI1 or SI2 jumps, the probe function is triggered, and the probe value is locked in the corresponding COE object words 0x60BA to 0x60BD. When reading the probe value, you need to add the corresponding probe value object (0x60BA-0x60BD) to TxPDO to facilitate data collection.

Select 1600, 1A00 in **Expert process data** → **PDO list**, add 60B8h in 1600, add 60BAh in 1A00, 60BCh (take the rising edge of the two probe signals as an example. If the falling edge is collected, 60BBh and 60BDh can be added).

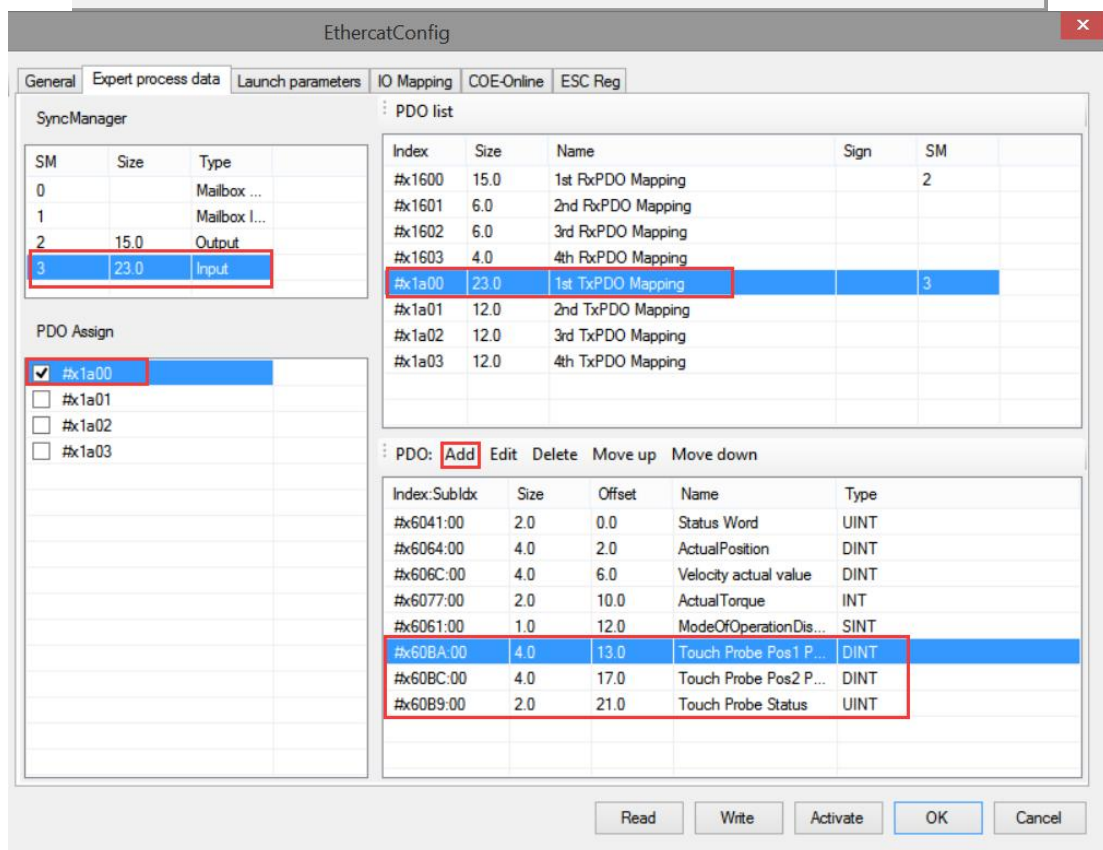
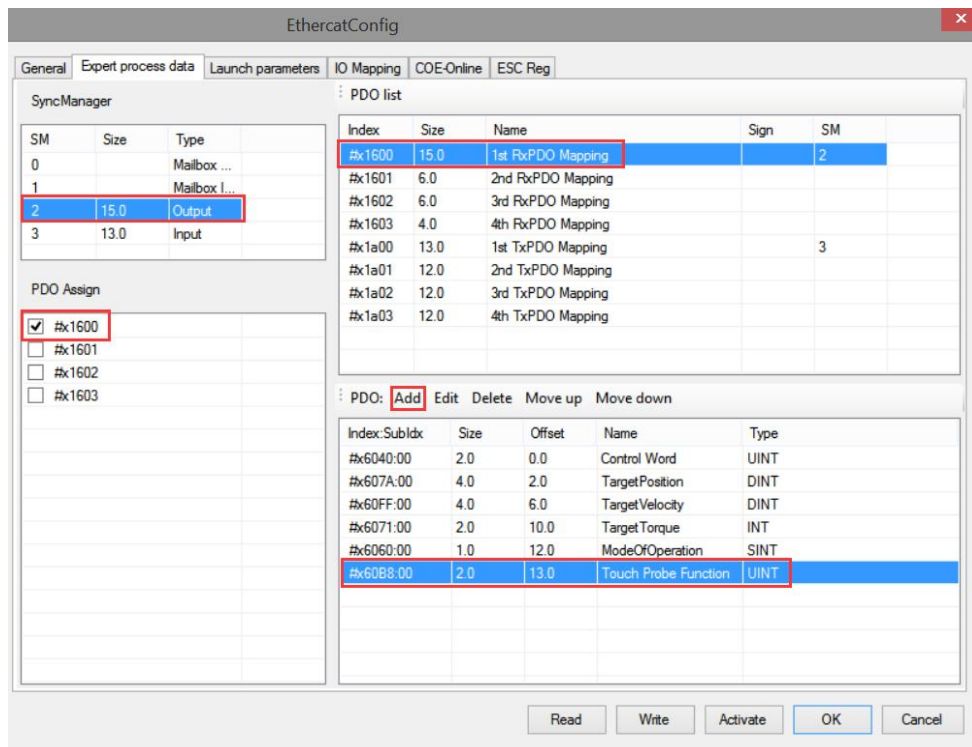

④ 【IO mapping】 The default starting address is HD10000, which can be changed if necessary

⑤ After configuring the parameters, click 【write】 → 【activate】 → 【OK】 , the parameters will take effect after the activation is successful.

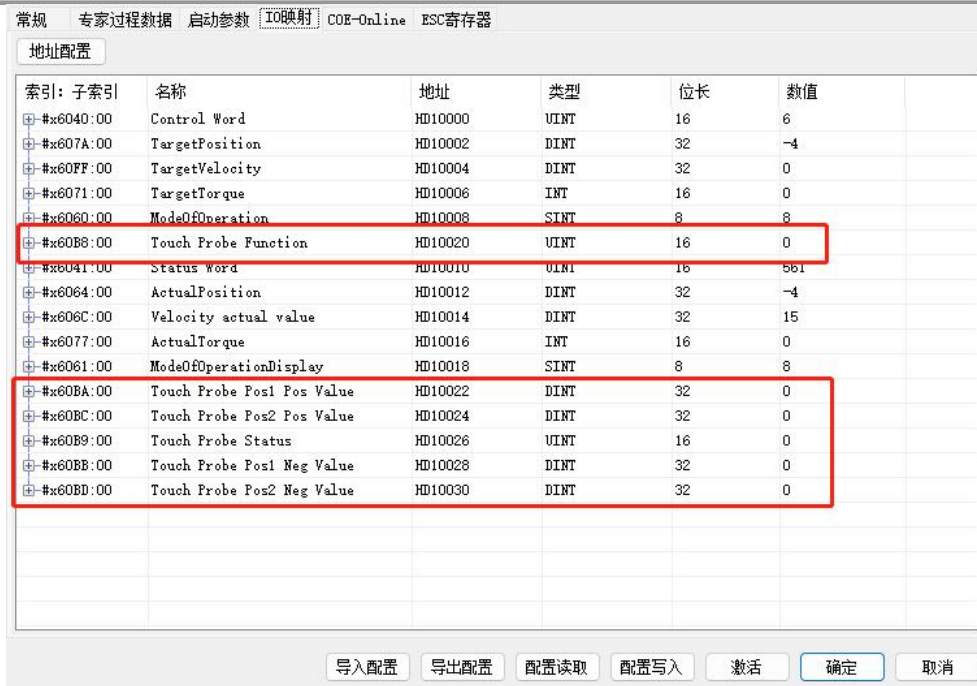
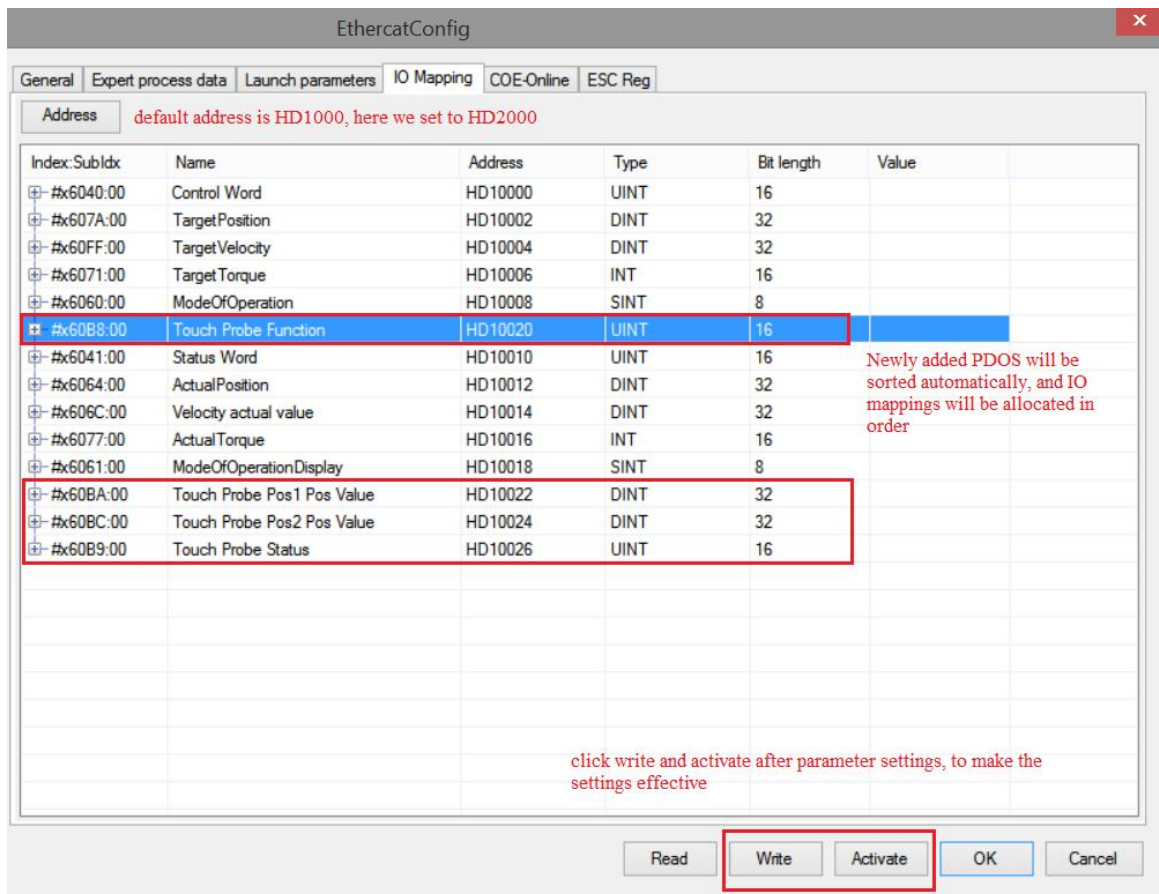

- ⑥ After activation, the slave station state machine (SD8021) will change from 1 → 2 → 4 → 8, 8 indicating the OP state. At this time, both SDO and PDO can receive and send messages.
- ⑦ After enabling the slave station, the probe function can be activated by modifying HD10024 (60B8h mapping).
- ⑧ After activating the probe function, the rising edge clamping value of probe 1 can be monitored through HD10022 (60BAh mapping), the rising edge clamping value of probe 2 can be monitored through HD10024 (60BCh mapping), the current probe status can be monitored through HD10026 (60B9h mapping), the current actual position of the motor can be monitored through HD10012 (6064h), and the current actual speed can be

monitored through HD10014 (606Ch mapping).

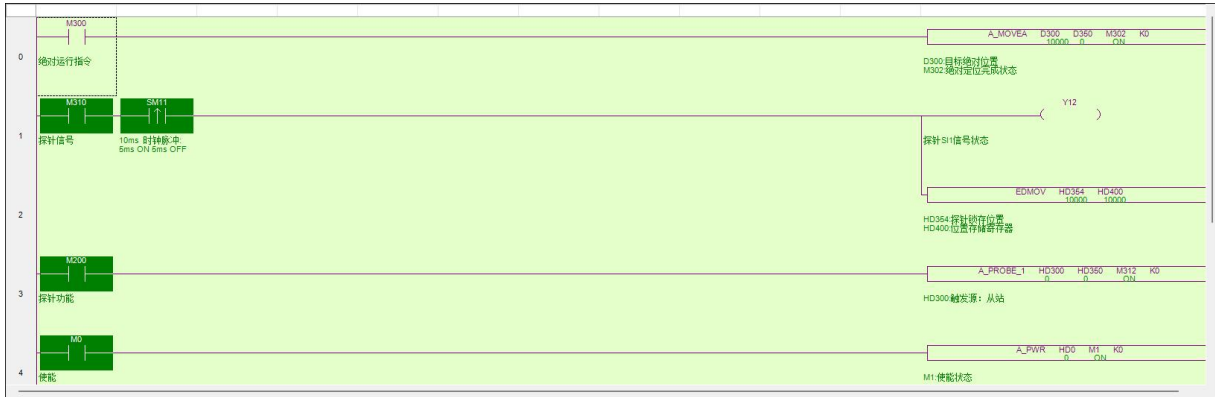

PLC1-自由监控1					
监控窗口 ▾ 添加 修改 删除 全部删除 上移 下移 置顶 置底					
名称	监控值	类型	映射地址/字长	注释	
M0	ON	BIT	位	使能	
M1	ON	BIT	位	使能状态	
D10	0	UINT	单字	控制模式	
M300	OFF	BIT	位	绝对运行指令	
D300	1000000000	LREAL	四字	目标绝对位置	
D304	10000	LREAL	四字	目标速度	
D308	5000	LREAL	四字	加速度	
D312	5000	LREAL	四字	减速度	
D316	100	LREAL	四字	加加速度	
M302	OFF	BIT	位	绝对定位完成状态	
M200	ON	BIT	位	探针功能	
M310	ON	BIT	位	探针信号	
Y12	OFF	BIT	位	探针S11信号状态	
SM11	ON	BIT	位	10ms 时钟脉冲: 5ms ON 5ms...	
M310	ON	BIT	位	探针信号	
HD354	99140	LREAL	四字	探针锁存位置	
HD358	9965	LREAL	四字	探针锁存速度	
HD400	99140	LREAL	四字	位置存储寄存器	
HD10012	466533	DINT	双字	Station ID:0,#x6064:0,Actual...	

11.2 Beckhoff TWINCAT and Xinje DS5C1

Beckhoff TwinCAT control software is used as the master station and Xinje servo is used as the slave station to realize EtherCAT motion control.

11.2.1 System configuration

Name	Model	Quantity	Explanation
Upper computer software	TWINCAT XAE(VS 2013)	1	Application version used in this example: TC31-FULL-Setup.3.14022.27
Xinje servo	DS5C1-20P4-PTA	1	
Network cable	JC-CA-3	some	For connection between computer and servo driver

11.2.2 System topology

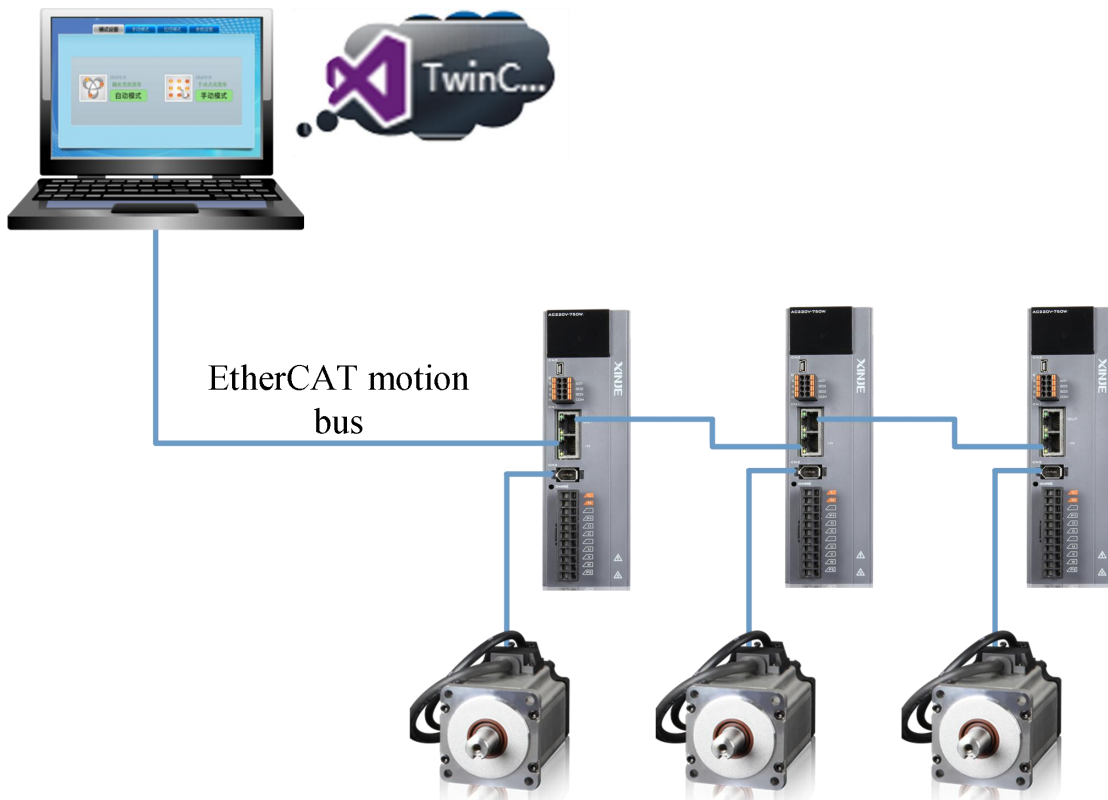

DS5C1 servo driver has two communication network ports, which follow the principle of "bottom in and top out" shall be followed when connecting. The master station must be connected with the network port under the CN1 port of the first servo, and then the network port above the first servo is connected with the network port below the second servo, and so on.

11.2.3 Commissioning steps:

1) Add XML file

Before opening the software operation, we need to copy the XML file to the TwinCAT installation directory, and the default path is C:\TwinCAT3.1\Config\Io\EtherCAT.

2) New project

Open the TwinCAT XAE(VS 2013) software and new a project.

(1)FILE—NEW—Project:

(2)Select TwinCAT Project, enter the project name and the project saving path, and click OK.

The following interface will appear:

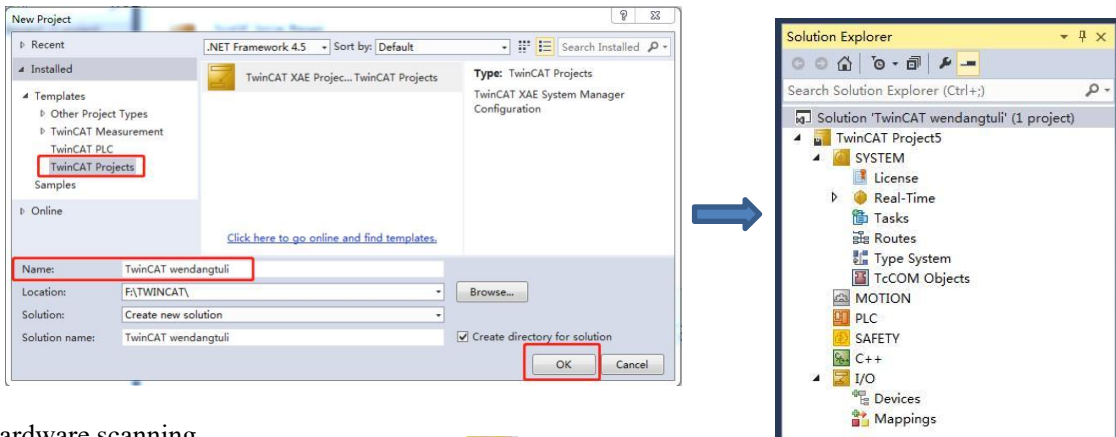

3) Hardware scanning

If the controller is not in config mode, click  to switch the controller to config mode first. Then right click "Device" and click "Scan" to scan the slave station of EtherCAT.

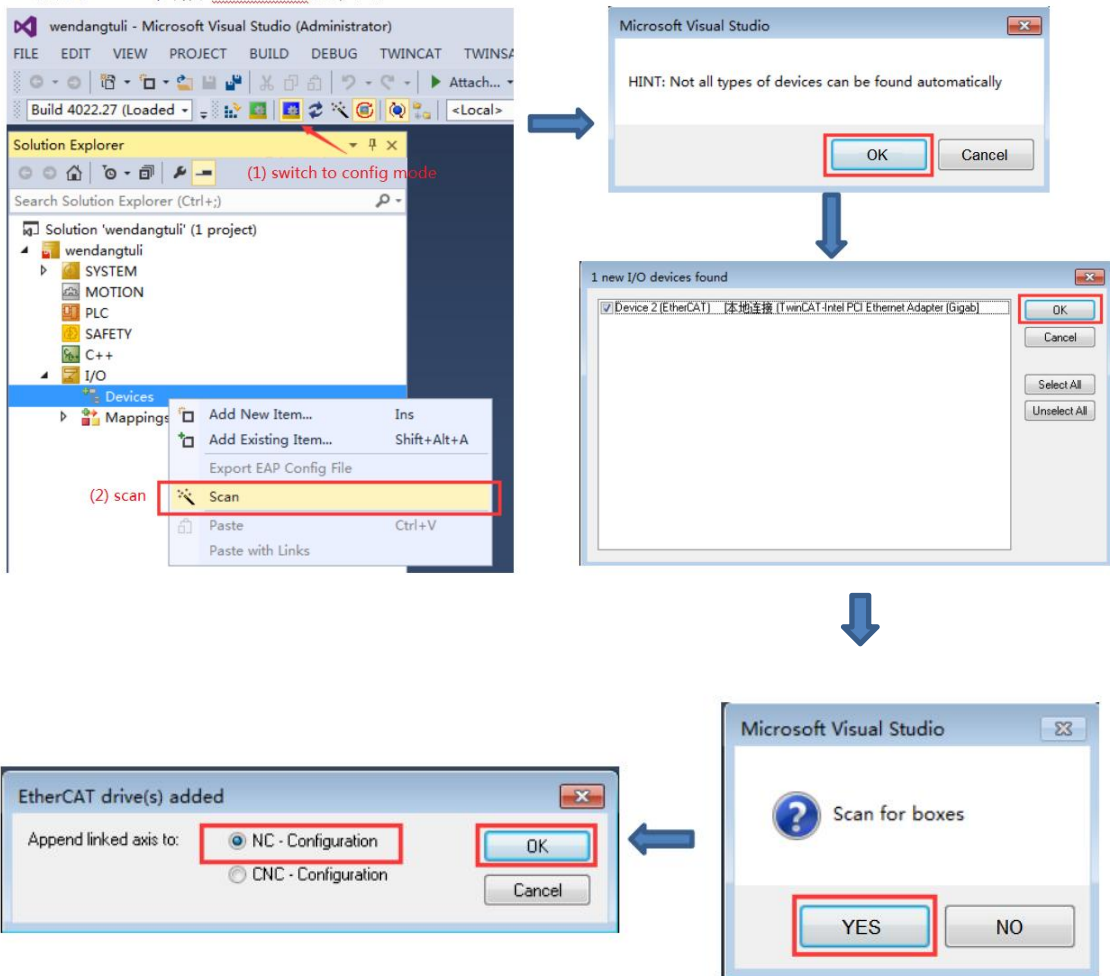

Click "NC Configuration".

After the scanning is completed, Axis1 can be seen in "Motion-NC axis", corresponding to the servo motor connected to the servo driver, and DS5C1 can be seen in the "Device".

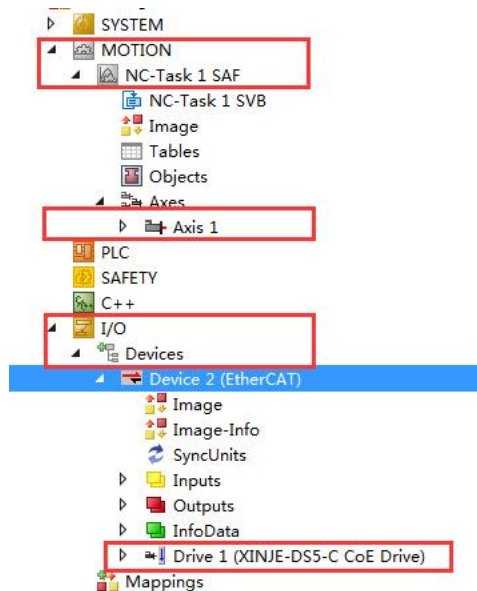

4) Connect NC axis and physical axis

Method 1: Click “Axis1-Settings-Link to I/O ...” to select the physical axis associated with the NC axis. This link will be automatically added when scanning the hardware.

Method 2: Manually right click Axis and click Append axis. Link the NC axis to the physical axis manually.

In this window, you can see the corresponding relationship between the NC axis and the physical axis

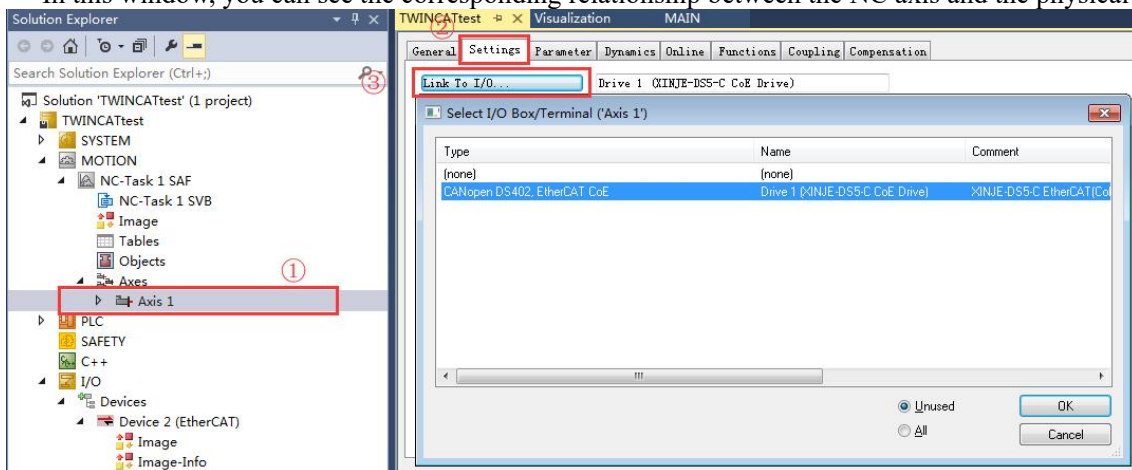

5) Debugging through NC-Online interface

(1) Switch TwinCAT to the running mode, and then click “MOTION- Axis1- Online” to debug the servo axis.

(Note: if you don't see the current position of the shaft in the “Online”, please make sure that the motor model addition and activation configuration are completed normally.)

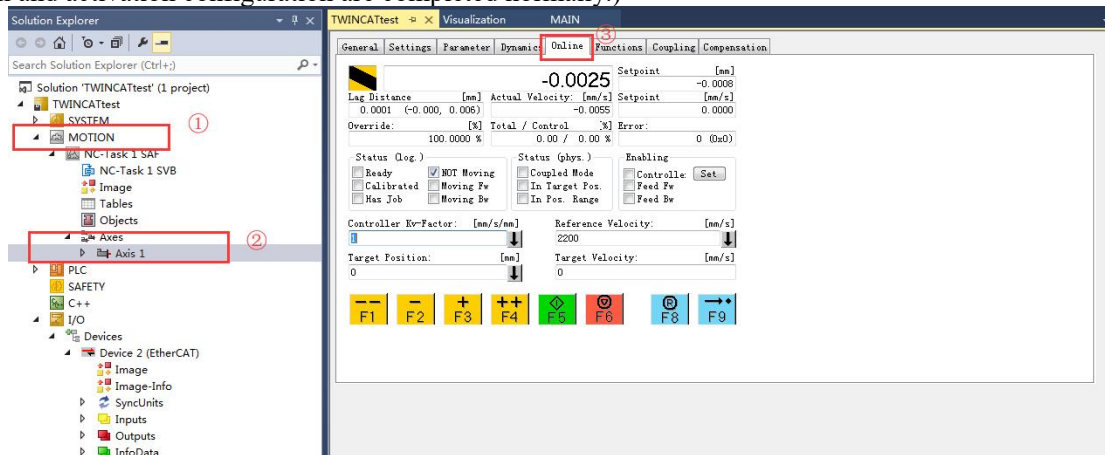

(2) Click Set, manually check Controller, Feed Fw, Feed Bw and set Override(%), then click OK.
Or directly click "All" to enable the axis, and automatically set the Override to 100%.

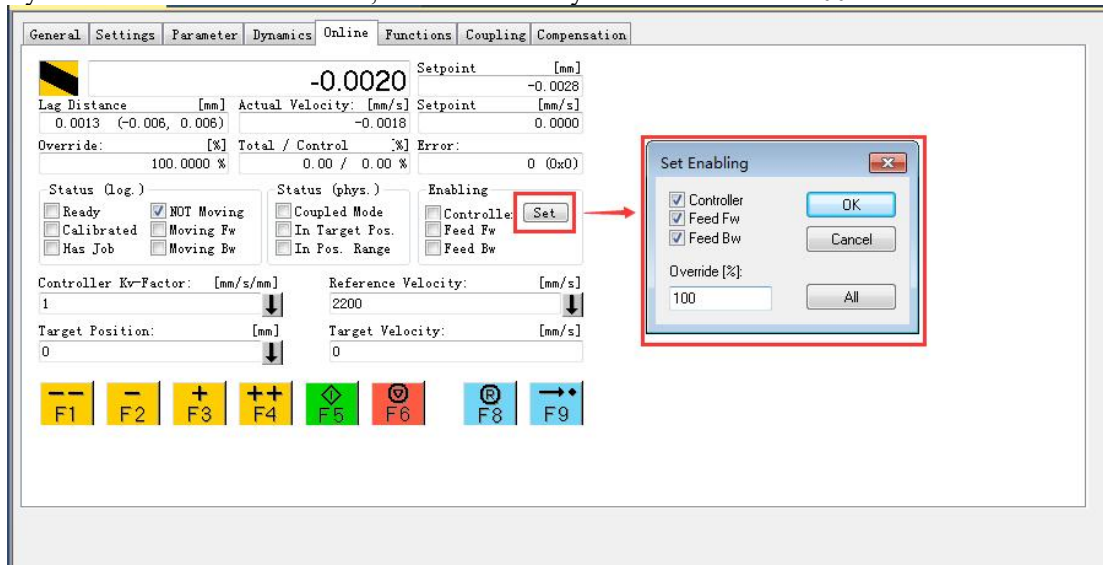

(3) If the Ready status is checked, it means that the motor is enabled. Then the axis can be inched through F1 ~ F4. The inching speed is set in the "Manual Velocity" in the "Parameter". The default speed is 100mm/s and 600mm/s, respectively corresponding to slow inching and fast inching.

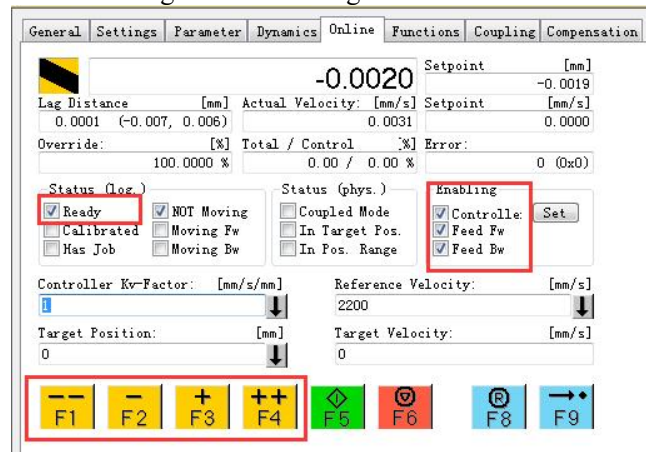

(4) After setting "Target position" and "Target Velocity", press F5 to realize position control. The motor will move to the target position with the set target. This positioning is absolute position positioning, and F6 can be used to stop during positioning.

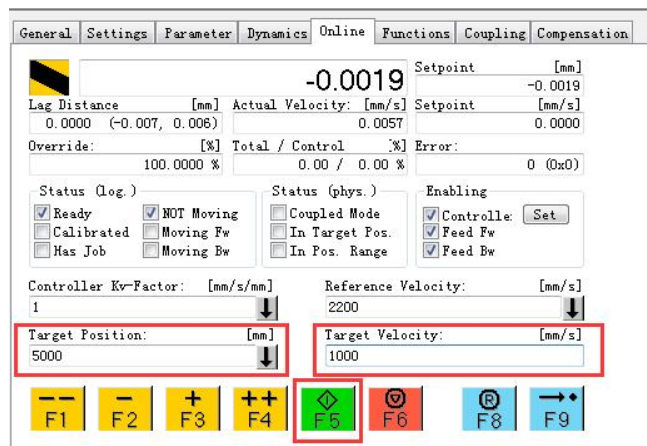

(5) When the NC reports an error, there will be an error code in the "Error".

F8 is the reset button. Press F8 to reset the error.

F9 is the origin finding button. After pressing F9, the axis position will change to 99999... And move slowly. However, the origin signal requires external hardware signal, which cannot be captured in the Online window. Therefore, F9 is not used to return to the origin generally, but realized through programming in the program.

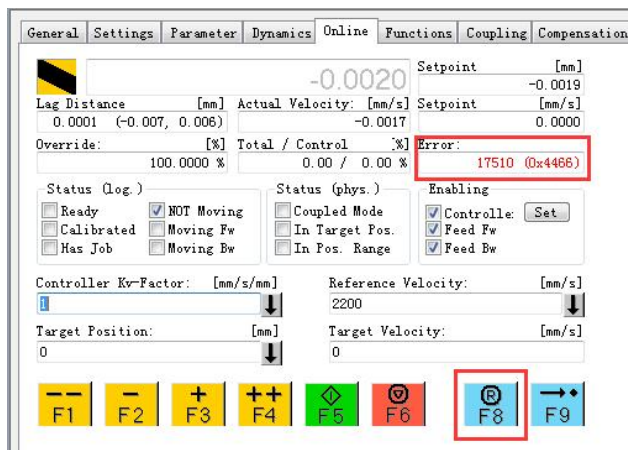

Note: Refer to "TC3 training material V1.1.0" for more single axis debugging functions.

6) Control DS5C1 servo motor by PLC control programming

(1) Add motion control library files and axis type variables

Create a new project under PLC and click "PLC-References-Add library...". In the pop-up dialog box, find "Motion -- PTP -- TC2_MC2" and select Add.

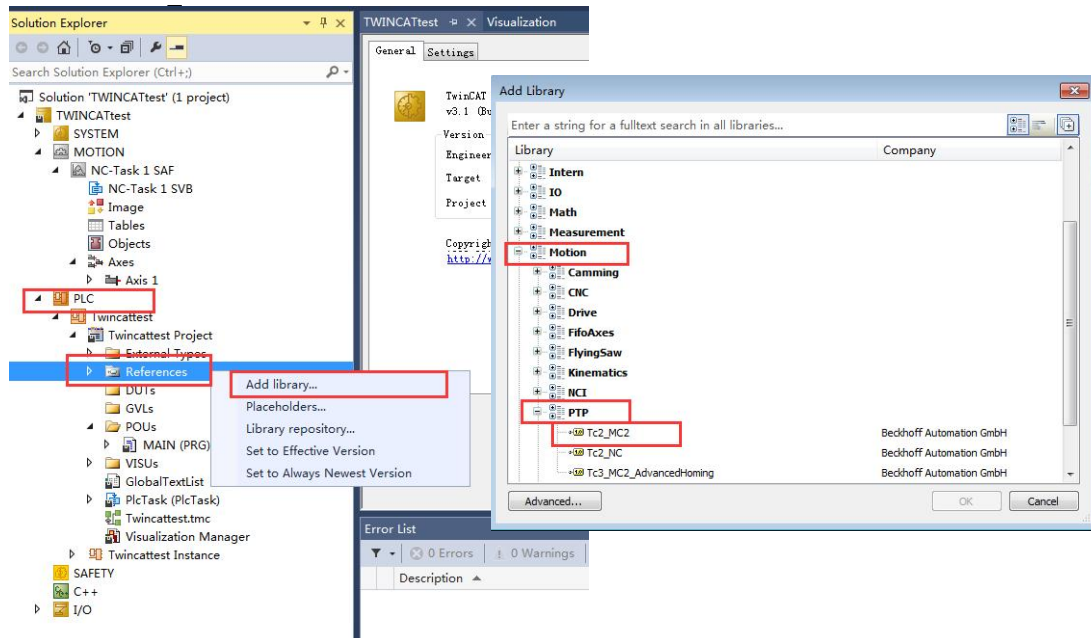

Click POU's -MAIN(PRG), create an Axis_ref type at the main program. Axis_Ref is a structure, mainly used for data exchange between NC and PLC. It also contains some other structures. We call this Axis_ref variable the axis variable.

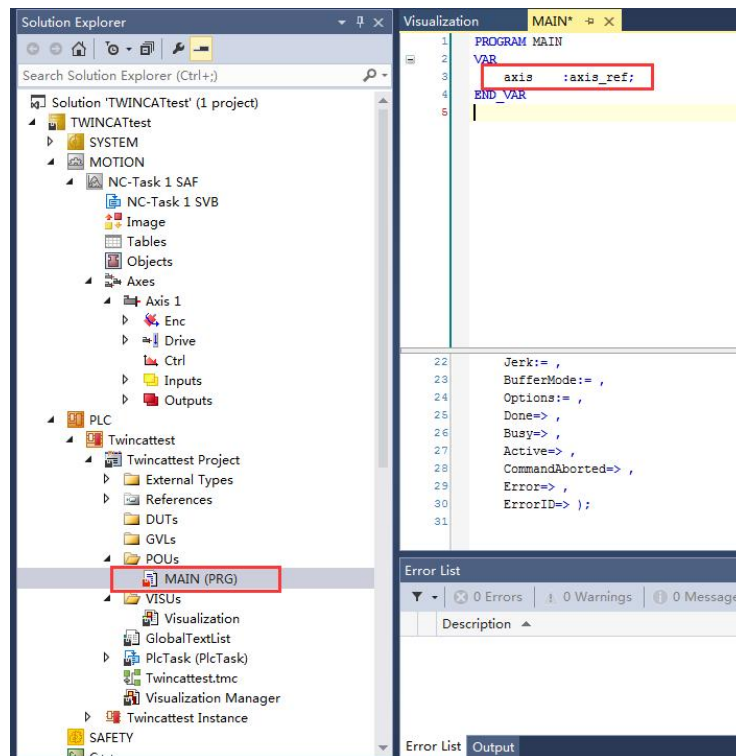

After the program is written, compile it to see if it is wrong. The project of this instance is named Twincattest, so find Twincattest project, right-click it, and then select “Build” and click it.

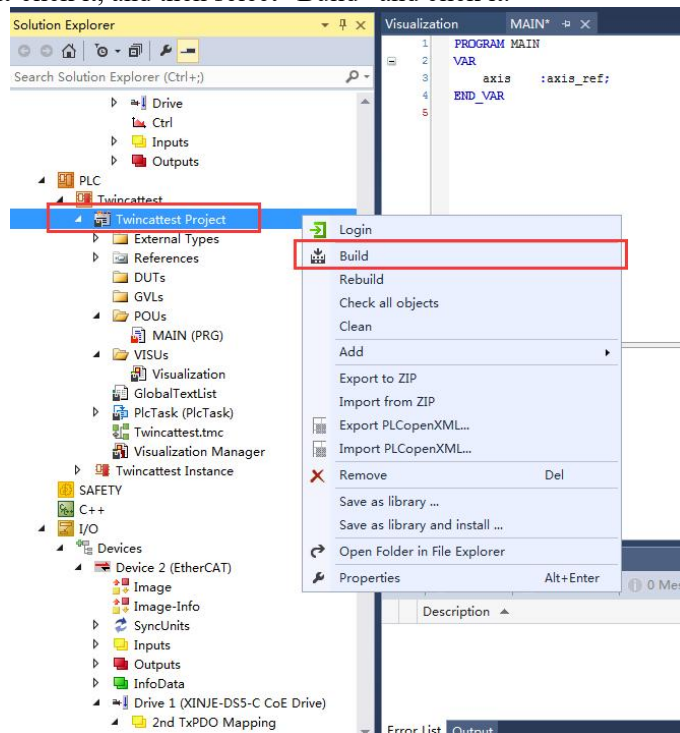

The corresponding variables can be seen in the Instance directory after compile successfully.

After **Build** successful compilation, you can bind two variables under PlcTask Inputs and PlcTask Outputs respectively.

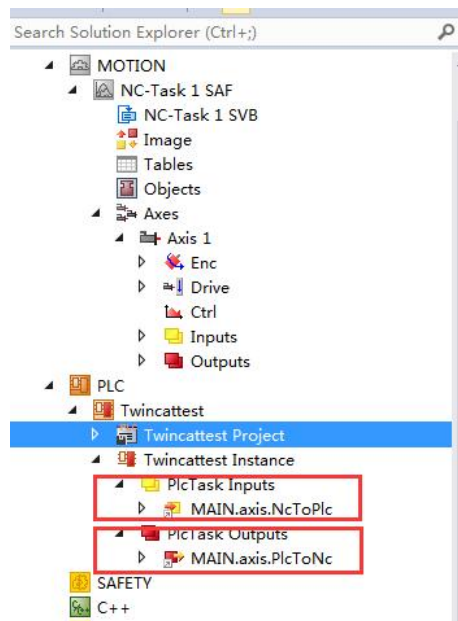

(2) Connect variable between NC and PLC

Click “Motion-Axes”, double click Axis 1, find “Settings-Link to PLC...” from the interface on the right. Link Axis1 to the corresponding PLC, and then NC and PLC can interact with each other through this link.

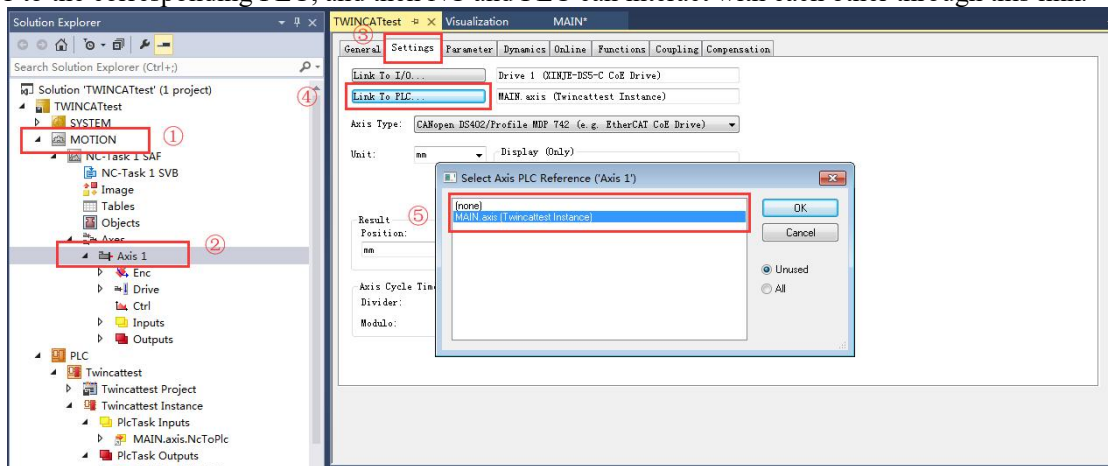

(3) Call function block to control the axis motion

On the POU-MAIN (PRG) interface, declare one MC_POWER function block and one MC_MoveAbsolute function block, where MC_Power is used to control shaft enable, MC_Moveabsolute is used to control the absolute position of the axis.

```

PROGRAM MAIN
VAR
    axis          :axis_ref;
    power         :MC_POWER;
    move_absolute :MC_MoveAbsolute;

```

Press F2 in the program writing window and select power and move_absolute in “Categories—Instance Calls” to call the defined function block into the program.

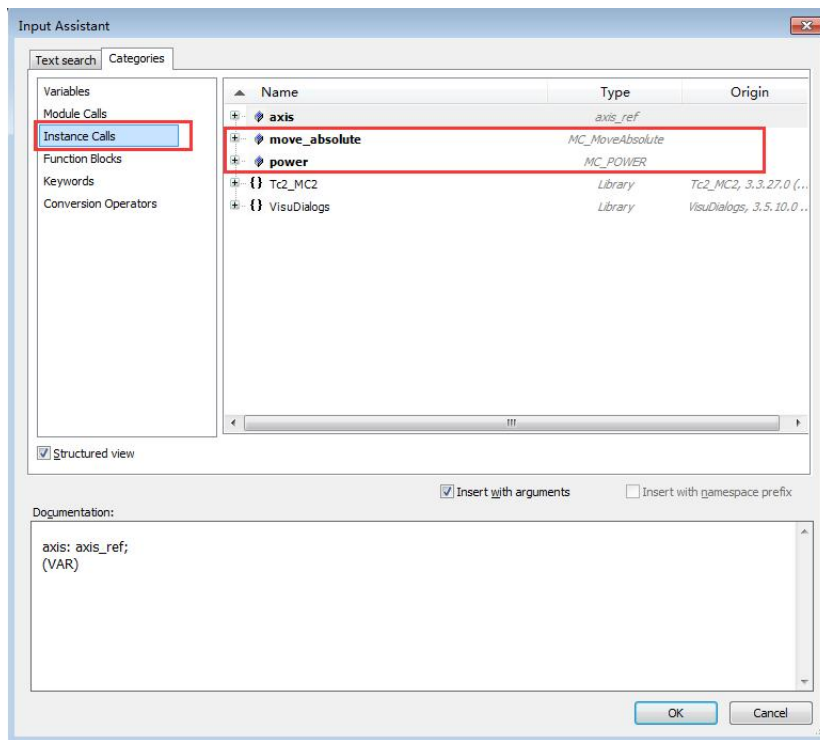

Complete the parameters in the function block.

In addition, declare two bool type variables `power_do` and `move_do` used as the trigger bit of the enable and absolute position motion function block, and the Lreal type variable is declared as the position, speed, acceleration and deceleration of the absolute position motion.

```

MAIN  → X
1    PROGRAM MAIN
2    VAR
3    axis          :axis_ref;
4    power         :MC_POWER;
5    move_absolute :MC_MoveAbsolute;
6
7    power_do      :BOOL;
8    move_do       :BOOL;
9    move_position : LREAL;
10   move_velocity : LREAL;
11   move_ac       : LREAL;
12   move_de       : LREAL;
13 END_VAR
14

```

```

move absolute(
Axis:= axis ,
Execute:= move_do ,
Position:= move_position,
Velocity:= move_velocity,
Acceleration:= move_ac,
Deceleration:= move_de,
Jerk:= ,
BufferMode:= ,
Options:= ,
Done=> ,
Busy=> ,
Active=> ,

```

```

power(
Axis:= axis,
Enable:= power_do,
Enable_Positive:=TRUE ,
Enable_Negative:=TRUE , |
Override:= ,
BufferMode:= ,
Options:= ,
Status=> ,
Busy=> ,
Active=> ,
Error=> ,
ErrorID=> );

```

Right click “PLC-VISUs”, click Add from the pop-up menu, and then select Visualization from the new menu to create a visual interface.

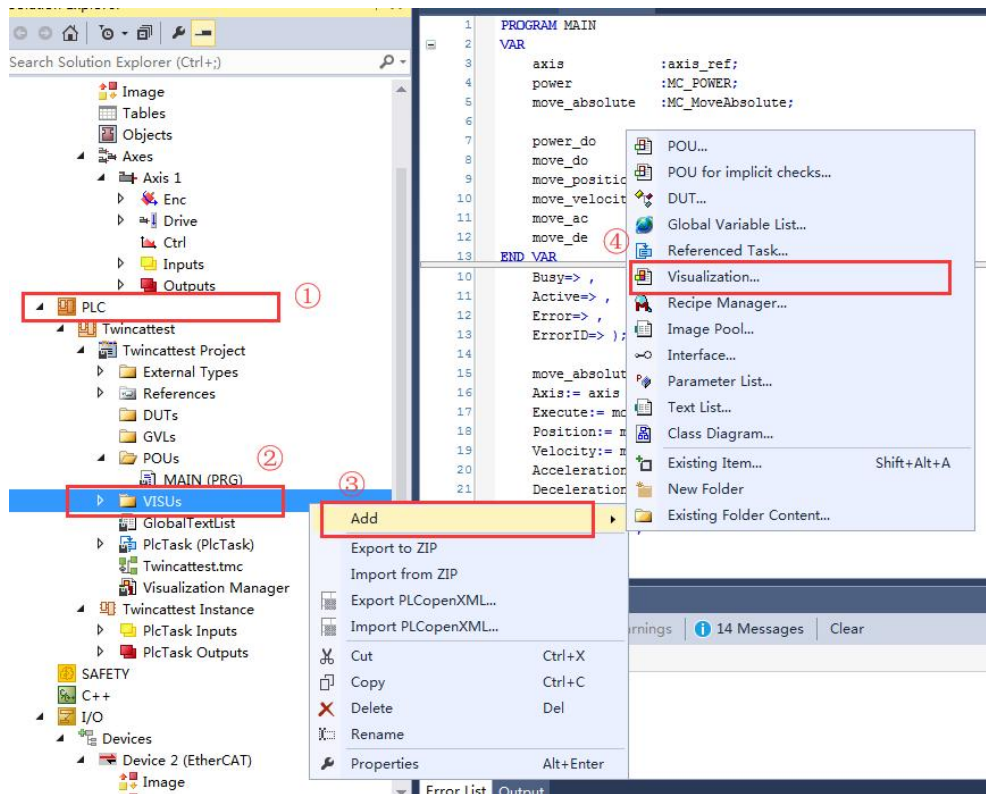

Select the rectangle in the toolbar of the added VISU interface and drag a control.

Double click the rectangle box control to set.

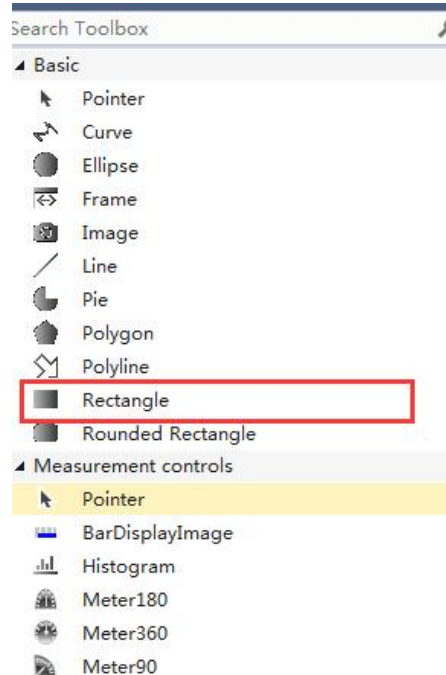

Double click the control, and set parameters in Property as shown in the figure.

Set Texts——Text-axis_pos: %.2f, %.2f represents the data type of floating-point number, display the value of the associated variable (that is, the variable pointed to by “Text variables——Text variable”, and only two decimal places are reserved.

Enter MAIN.axis.NcToPlc.ActPos in Text variable, indicating that the control points to the actual position in the axis variable.

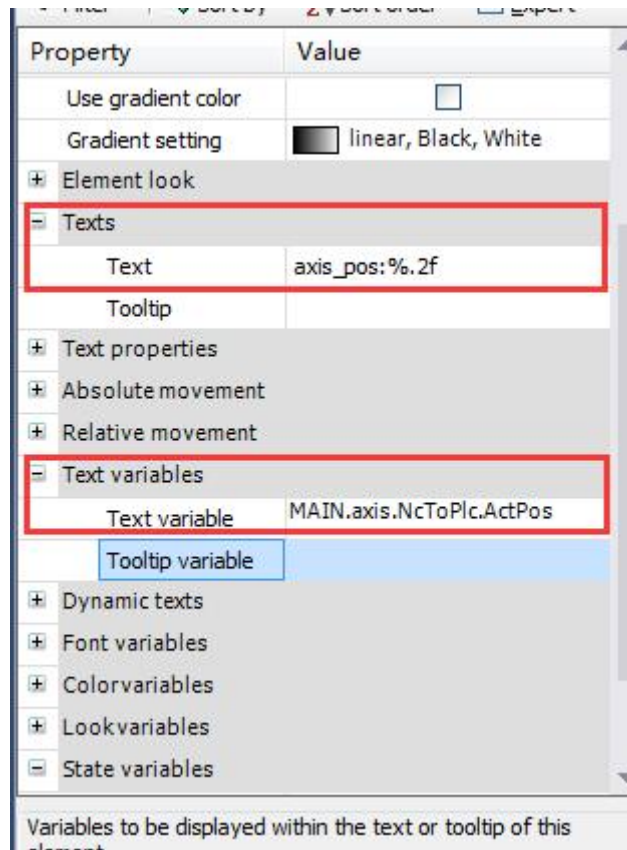

Make another control to represent the current speed of the shaft, enter MAIN.axis.NcToPlc.ActVelo in Text variable.

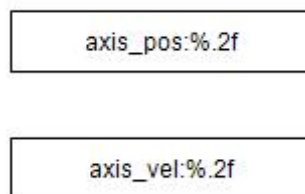

Add a rectangular control to input the target position value of the absolute position movement. The specific operations are as follows: create a rectangular control, and enter MAIN.move_position in Text variable (lreal type variable added in the program), click “Inputconfiguration - OnMouseClicked”, select “Write a Variable” in the pop-up interface, click “>” to add the function, and select “Use another variable” on the right to point to the variable MAIN.move_position.

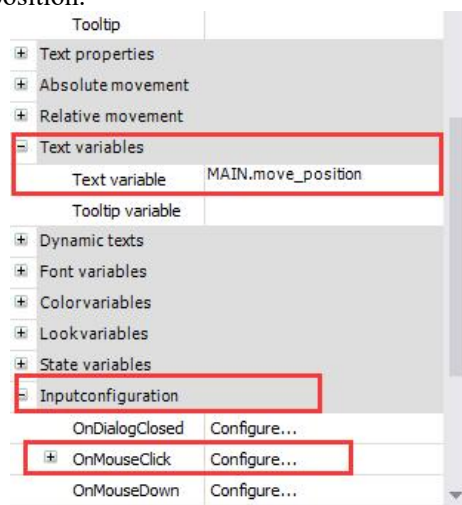

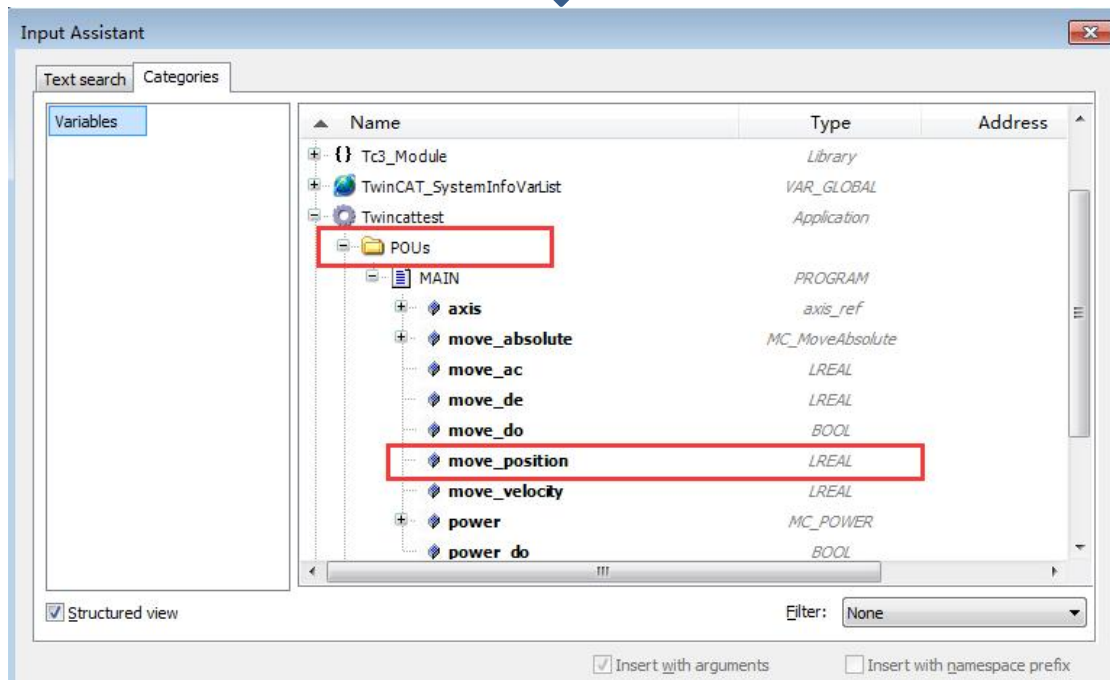
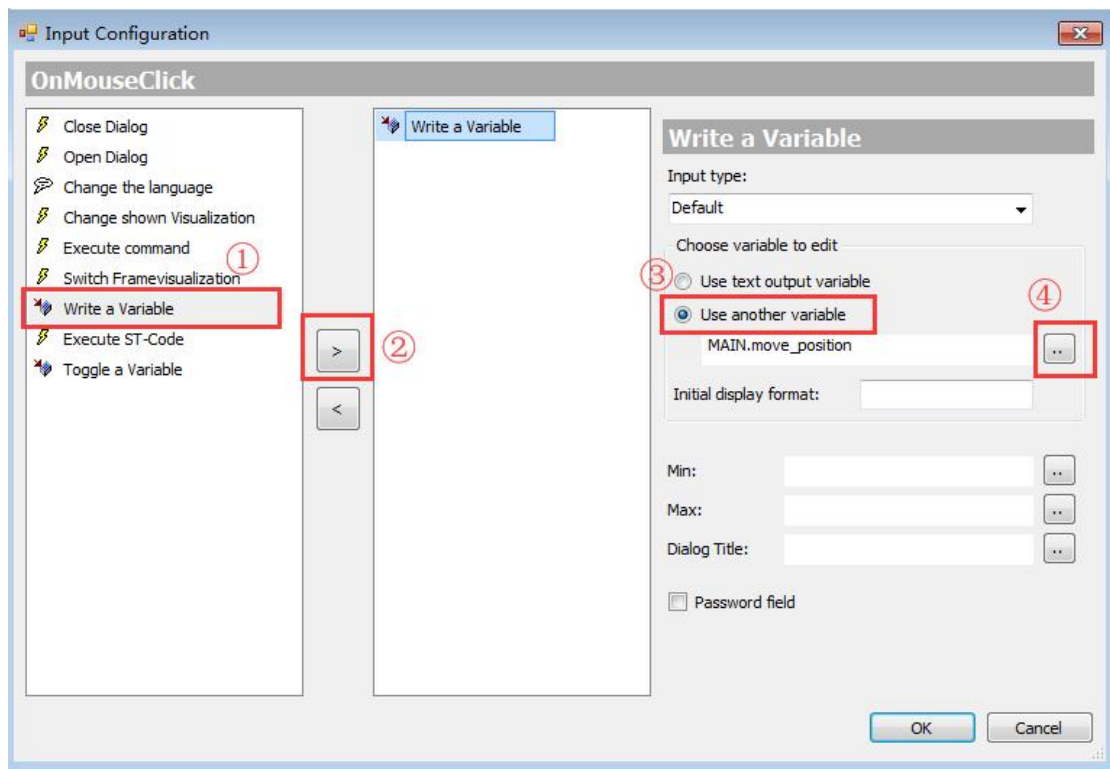

In the same way, create the controls of speed, acceleration and deceleration pointing to the absolute position.

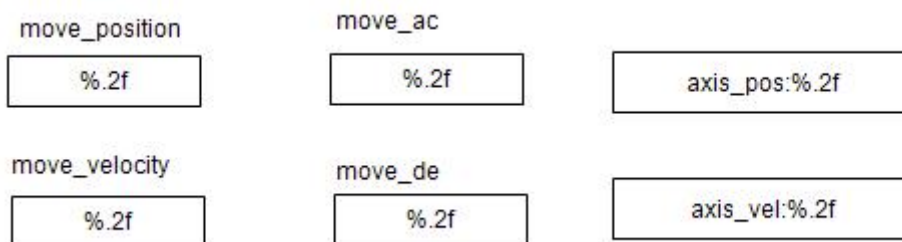

Create two button controls to control the enable and axis motion.

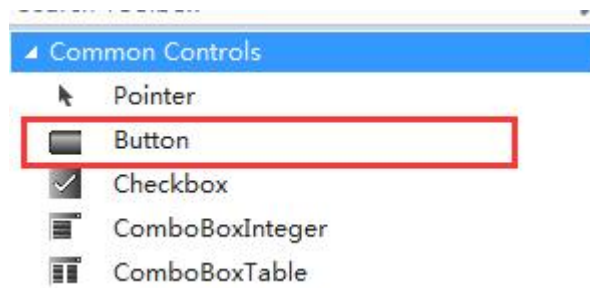

Enter “MAIN.power_do” in “Inputconfiguration—Toggle—Variable”, click once to set 1, and click again to set 0.

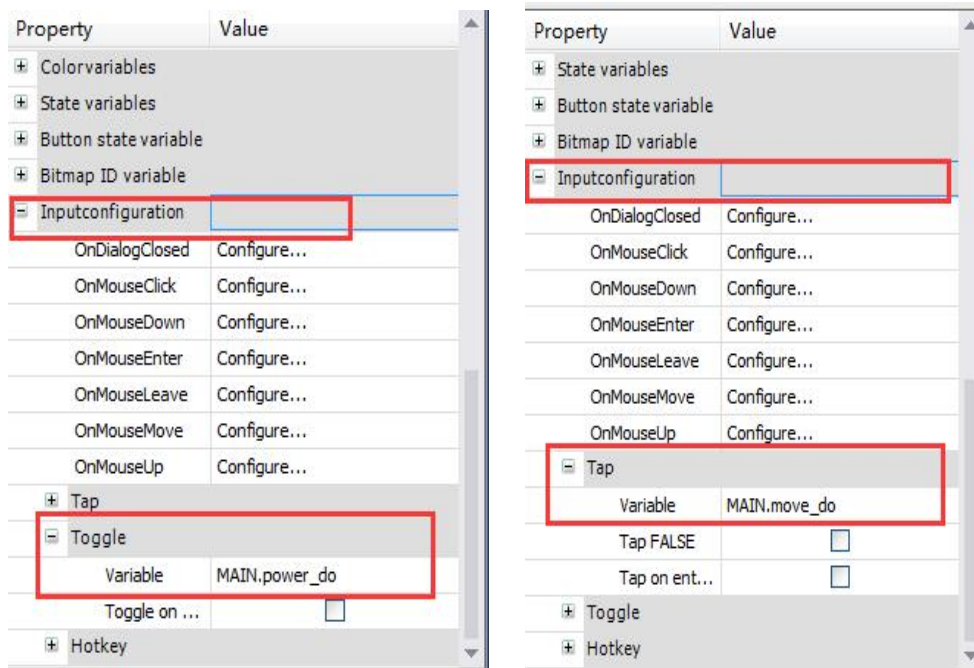

Enter “MAIN.move_do” in “Inputconfiguration—Tap—Variable” of the trigger control of axis motion_ Do, set 1 only when clicked, and 0 when released.

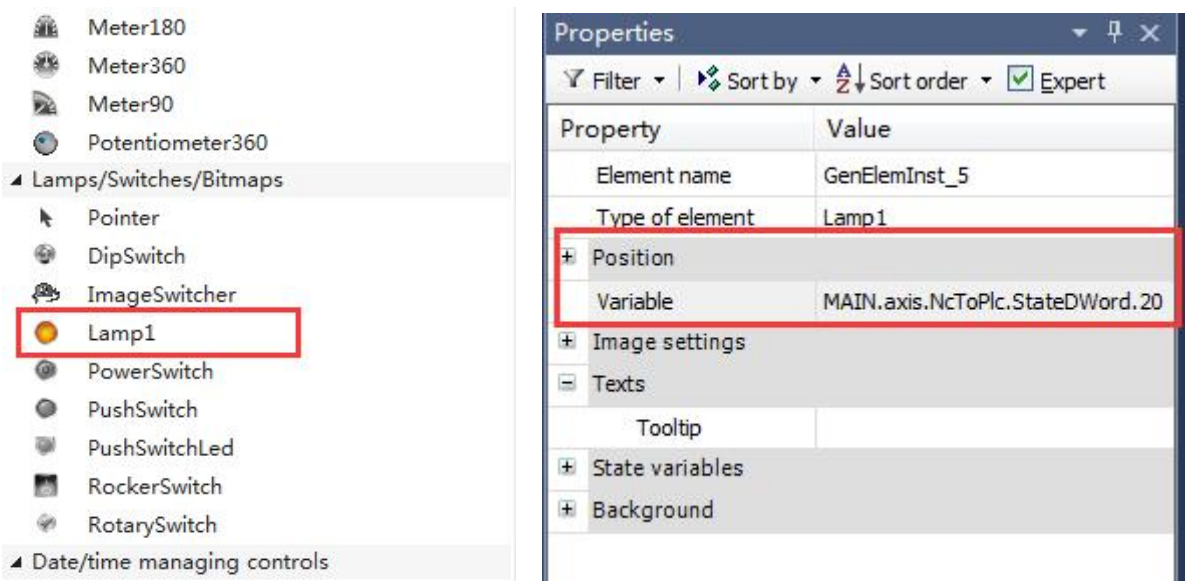

Create an indicator control to show whether the power function block is enabled successfully.

First, drag an LED icon from the Toolbox on the right, and then bind the “Position—Variable” to the MAIN.axis.NcToPlc.StateDWord.20 variable, where StateDWord “.20” represents the enabled state of the axis variable.



After the program is written, it needs to be activated, and then click Login  to run the program. Click the run  button to see the value of the specified variable in the visual interface.

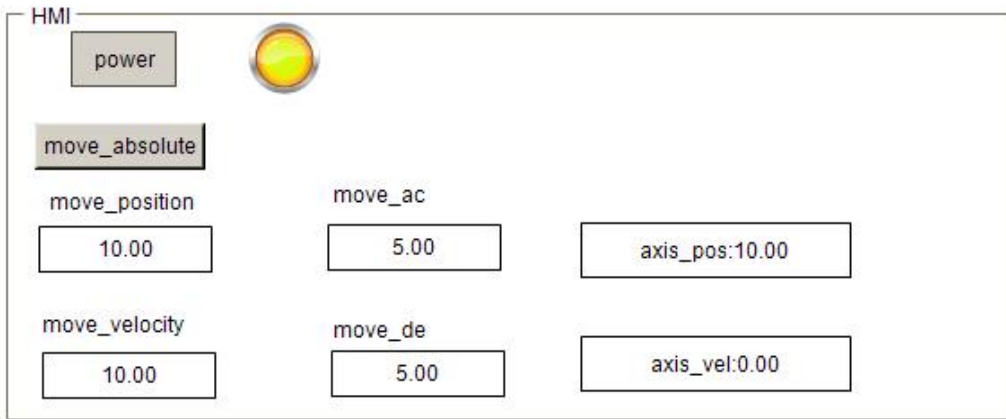

Click move_ Position and other input type controls can modify the value of the variable in real time.

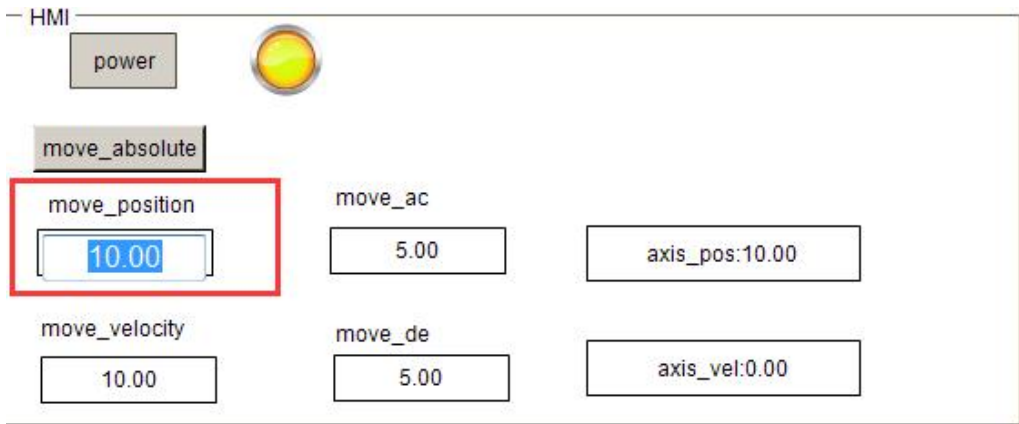

11.3 CODESYS and XINJE DS5C1 Ethercat communication example

This example will explain how Codesys motion control software realizes EtherCAT motion control when it is used as EtherCAT master station (Xinje XG3 series PLC is only used as a hardware platform) and Xinje DS5C1 series servo is used as slave station.

11.3.1 System topology

Name	Model	Quantity	Note
Software	CODESYS	1	Software version: V3.5 SP13 Patch 1
Hardware	XG3 series PLC	1	
Servo	DS5C1-20P4-PTA	3	
Network cable	JC-CA-3	Some	Connect PC and servo

11.3.2 System topology

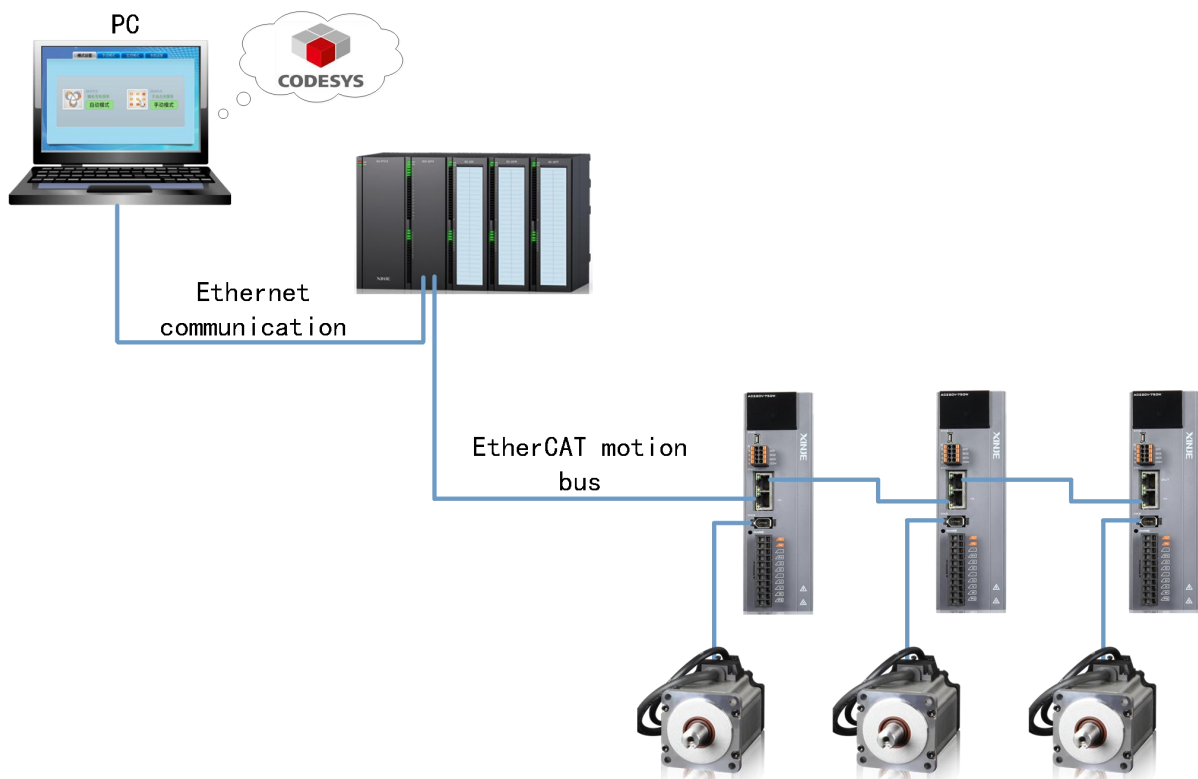

This is a Codesys control system based on traditional hard PLC. In this scheme, the PLC development system generally runs on an ordinary PC, while the traditional hard PLC only serves as a hardware platform. The real-time core of the soft PLC is installed in the traditional hard PLC, and the system program compiled by the development system is downloaded into the hard PLC. The control system diagram is shown in the above figure.

XG3 series PLC has upper and lower network ports. The upper network port is Ethernet/IP, which is used to connect the Codesys upper computer. The lower network port is an EtherCAT connection port, which is used to connect Xinje DS5C1 series servo to realize EtherCAT communication. The two communication network ports of Xinje DS5C1 series servo drivers should follow the principle of "bottom in and top out".

11.3.3 Debugging steps

1) New project

Double click  to open Codesys. Click New Project, input project name and save path.

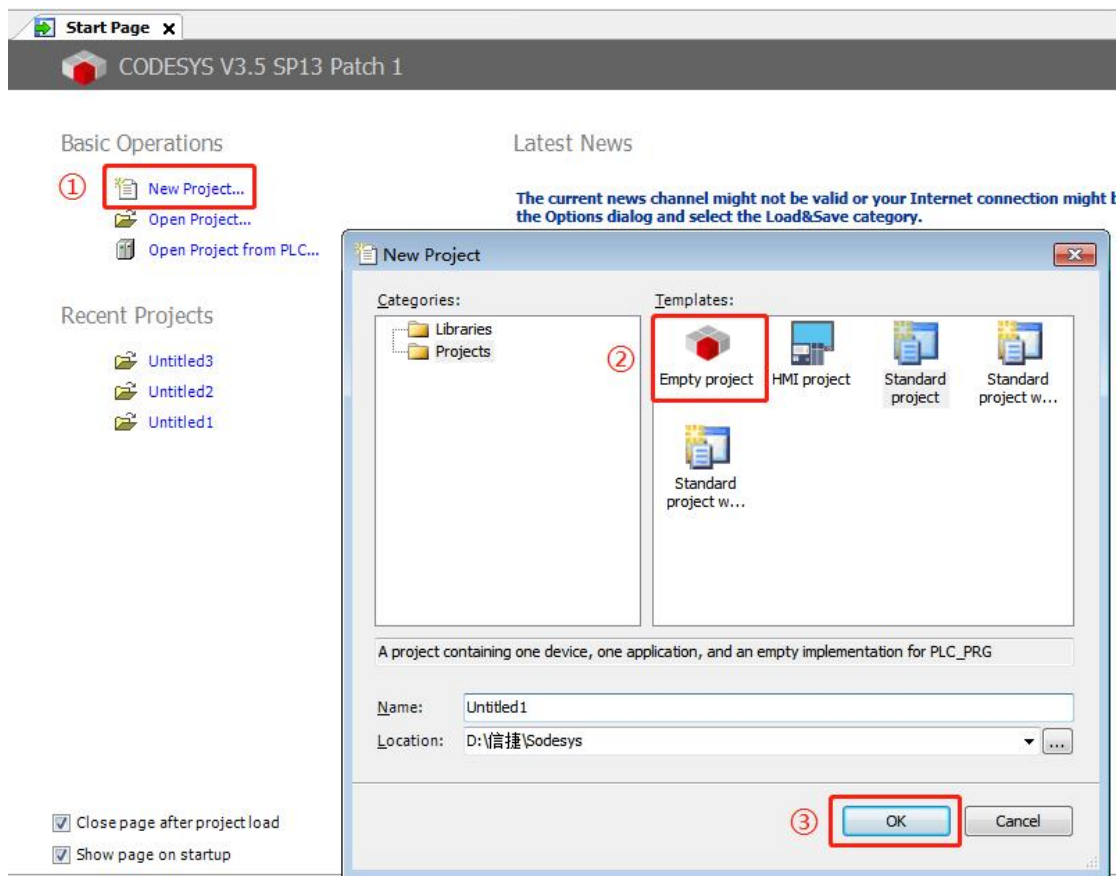

2) Add XML file

Open Tools/device repository, add XML file of master and slave station. First, add the XML file of the master station device. Click Tools -- device repository in turn, click install in the pop-up dialog box, select the path where the XML file is located, find the XML file, select it, and click open.

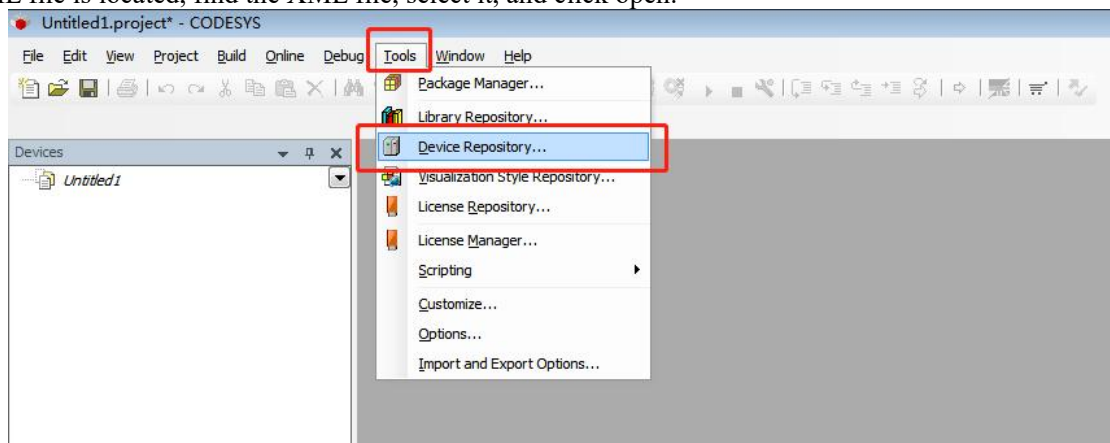

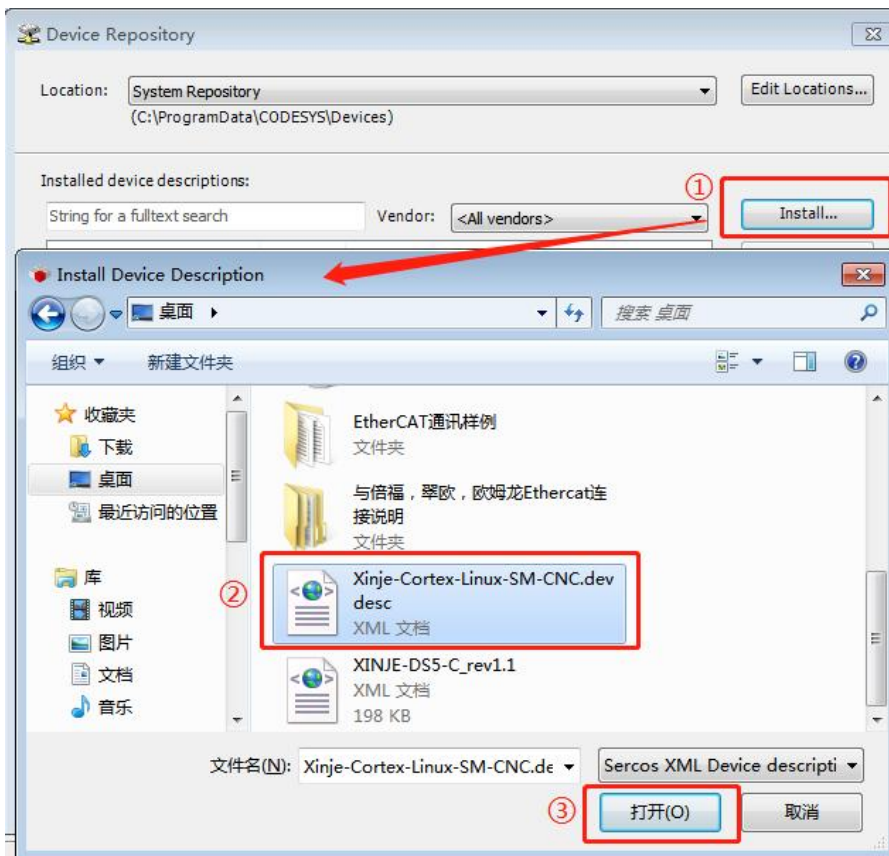

After opening, the installation is completed, as shown in the following figure. Similarly, install the slave XML file (Xinje-DS5-C_rev1.1) in the same way.

After opening, the installation is completed, as shown in the following figure. Similarly, install the slave XML file (Xinje-DS5-C_rev1.1) in the same way.

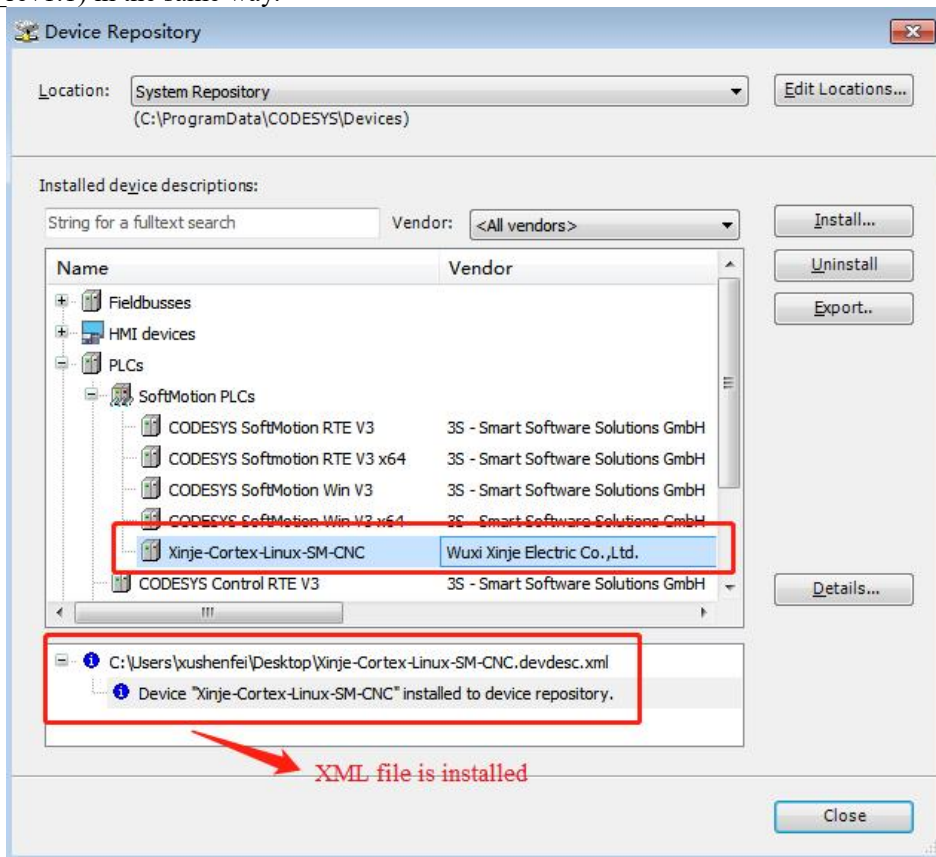

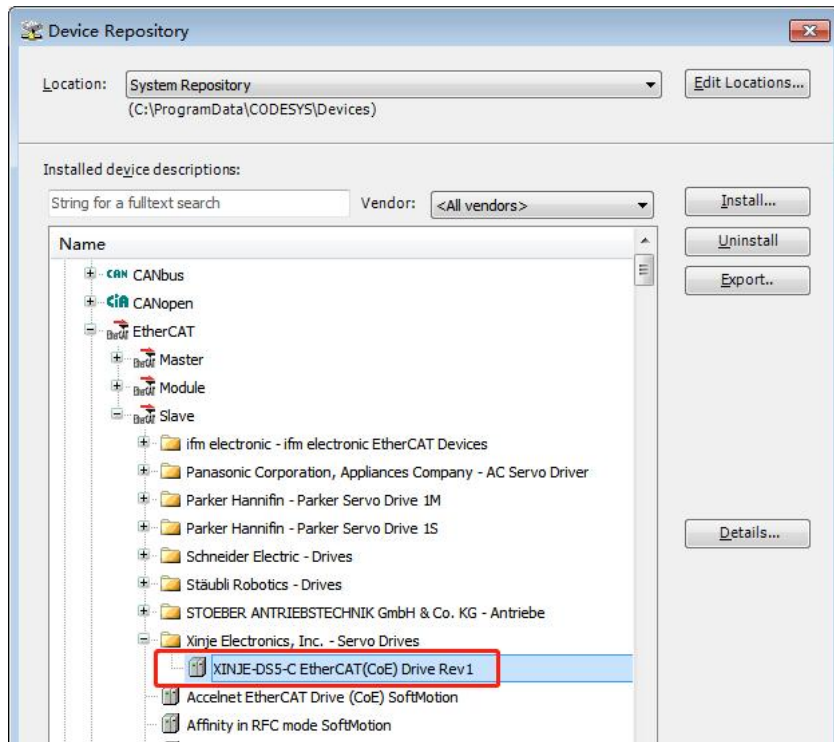

3) Add master station device

Right click Untitled, click Add Device, select PLCs--SoftMotion PLCs--Xinje –Cortex-Linux-SM-CNC, click Add Device to add the PLC.

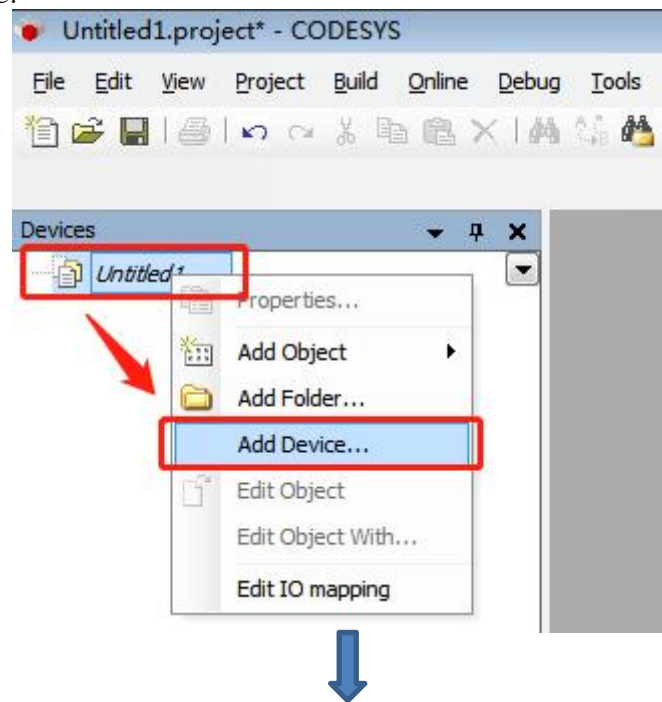

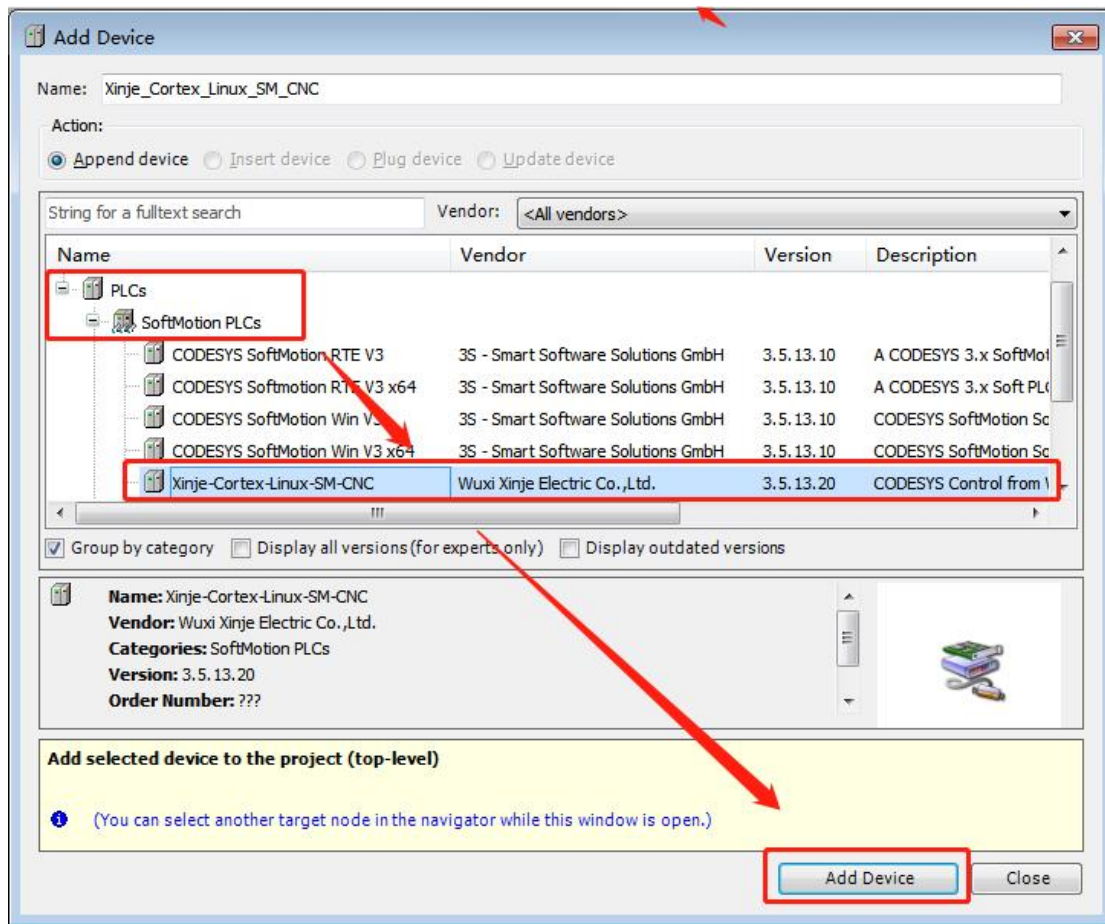

After adding a PLC, the device manager will appear on the right side of the interface. Select Xinje – Cortex Linux SM CNC, right-click, and click Add device.

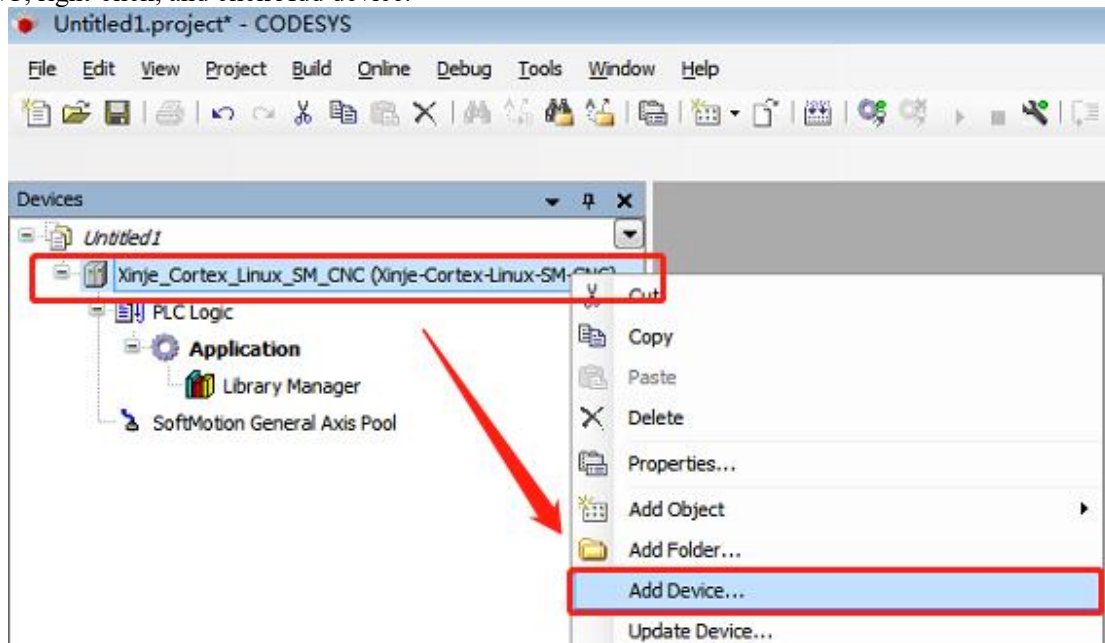

Select "EtherCAT / master/ EtherCAT master" in the "add device" dialog box, and finally click Add device.

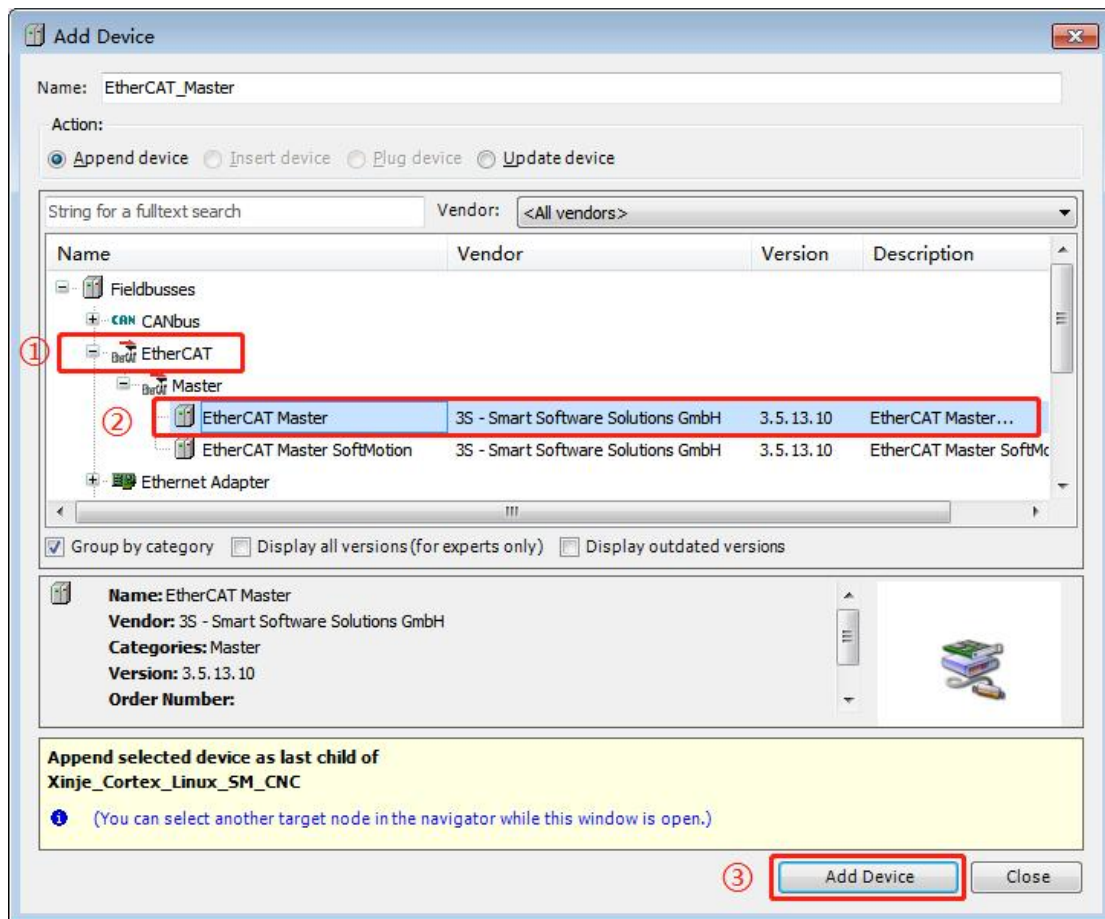

Add the device, as shown in the following figure:

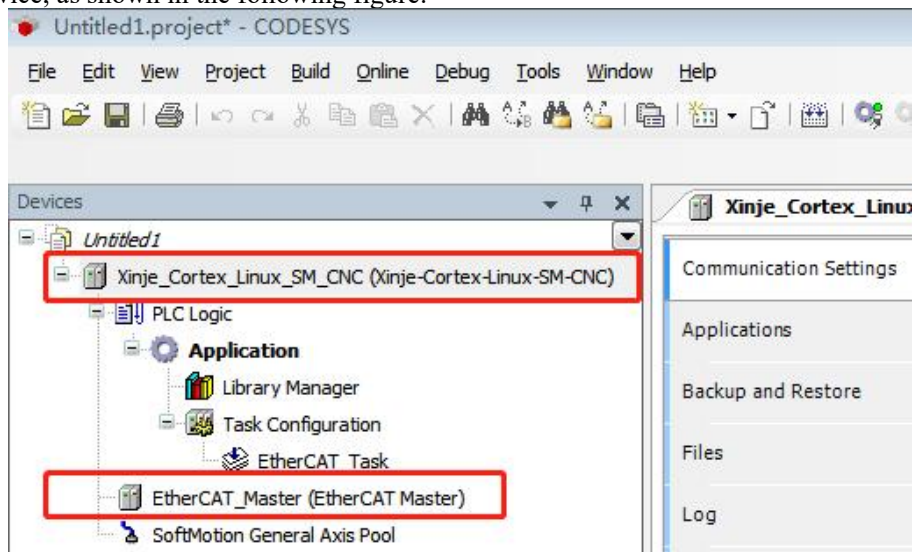

4) Gateway communication settings

Double click Xinje_Cortex_Linux_SM_CNC, click Scan network in the communication settings tab, search for PLCs in the same network segment, and click OK after finding them. As shown in the figure below, the equipment name of the PLC is XINJE-XS3.

Note: Ethernet connection requires that the IP address of the connected device (PC) and the IP address of the PLC are in the same network segment, so confirm whether the IP address setting of the PC meets the requirements before connecting.

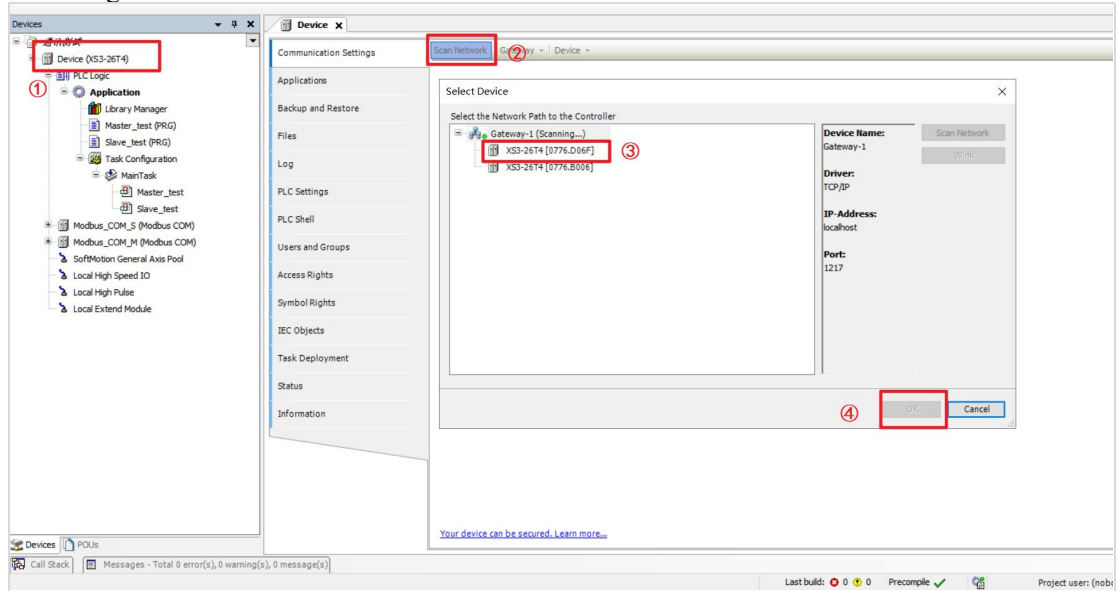

After successful communication, see the following figure:

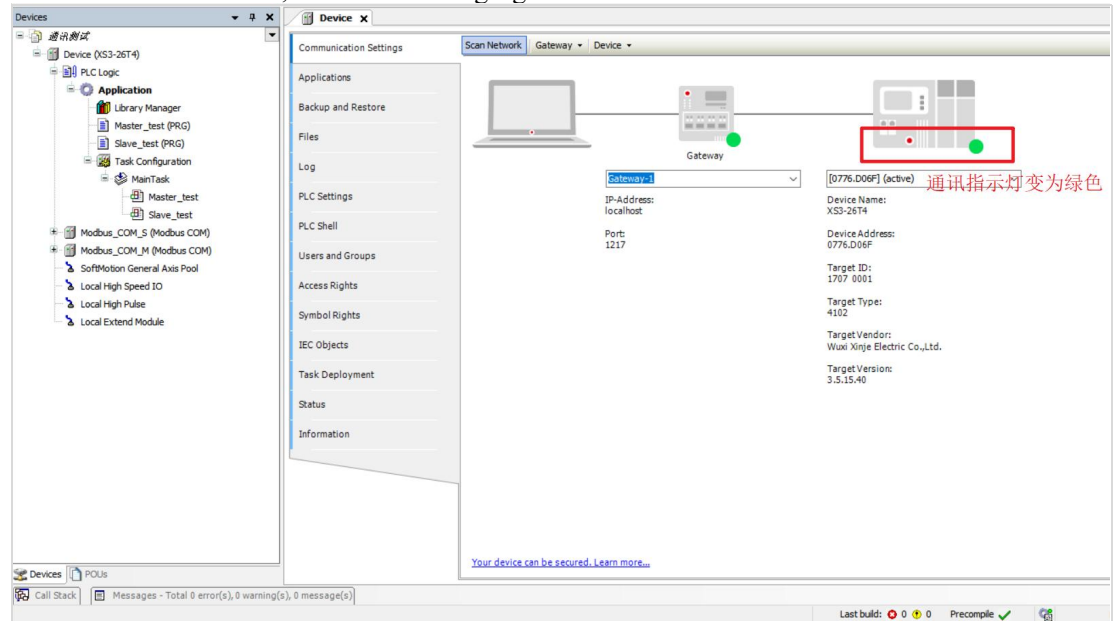

5) Scan the slave station device

In the device engineering bar, right-click EtherCAT_Master, click Scan for devices.

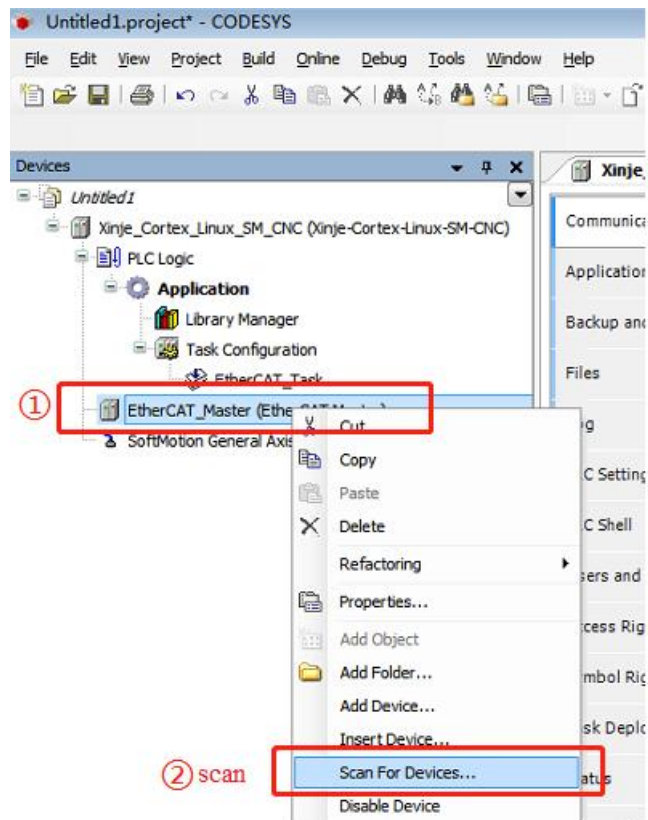

In this example, three DS5C1 series servos are connected. The scanning results are shown in the figure below. Click Copy All to Project to add all the slave stations scanned to the project.

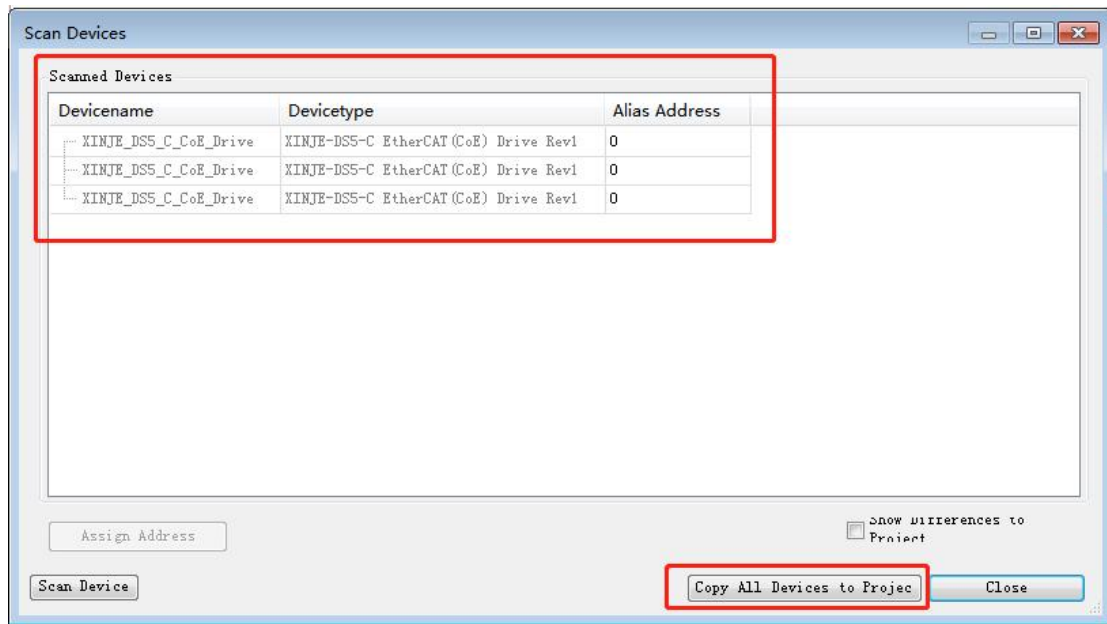

After the slave station equipment is successfully added, the "devices" is shown in the following figure.

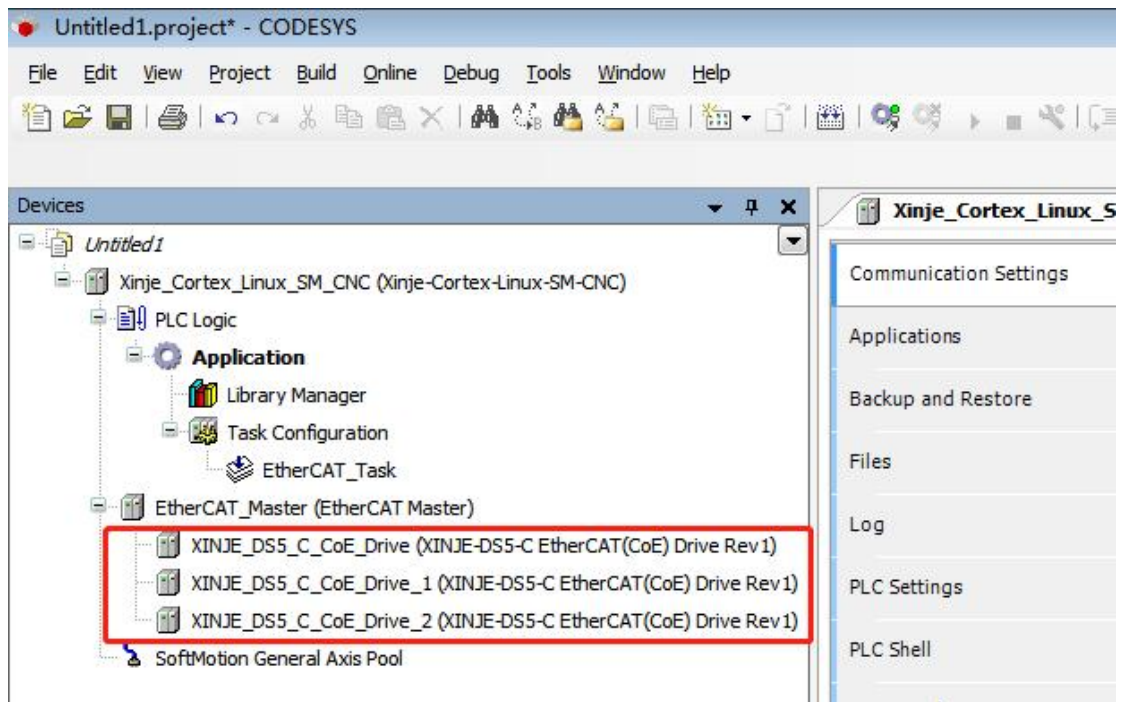

6) Add motion control axis

Select slave axis device XINJE_DS5_C_CoE_Drive, right-click, click Add SoftMotion CiA 402 Axis.

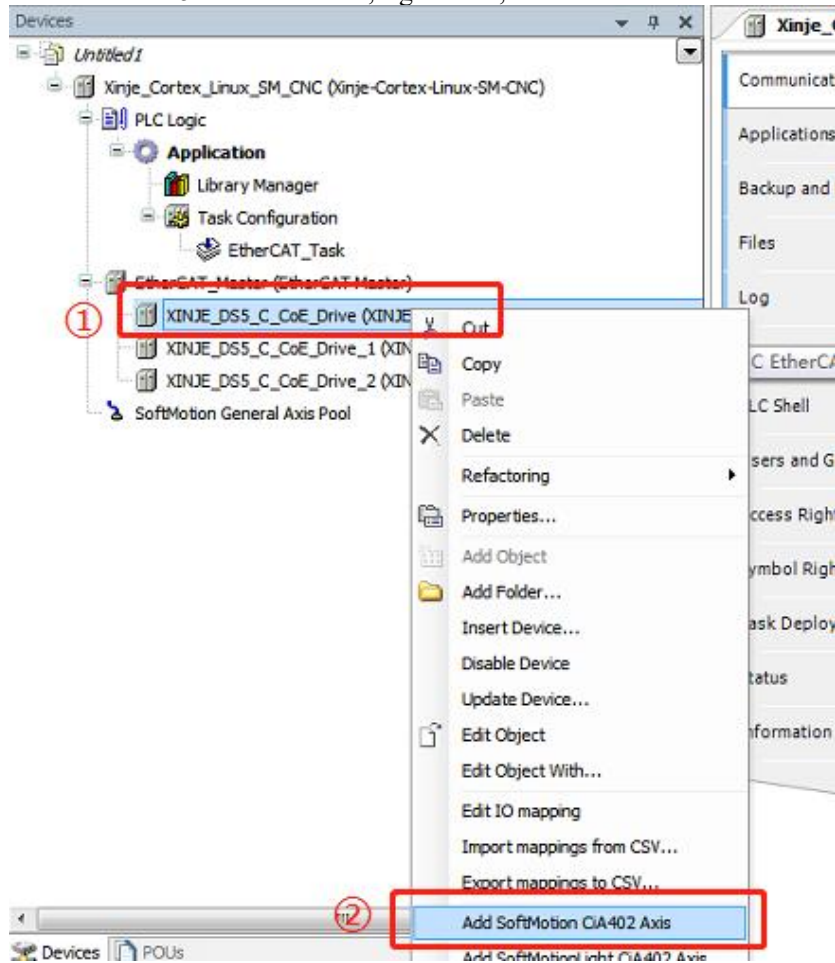

Similarly, add an axis for each slave station. After adding, it is shown in the following figure:

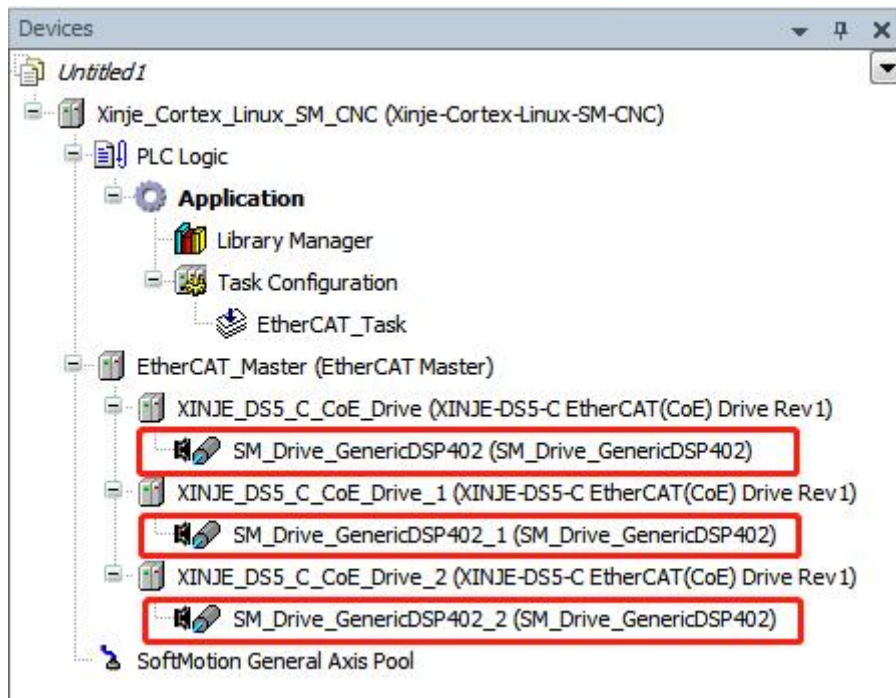

7) Master station device select source address

Double click “EtherCAT_Master”, click Browse... in general tab, select corresponding MAC address, click OK, now the source address is selected.

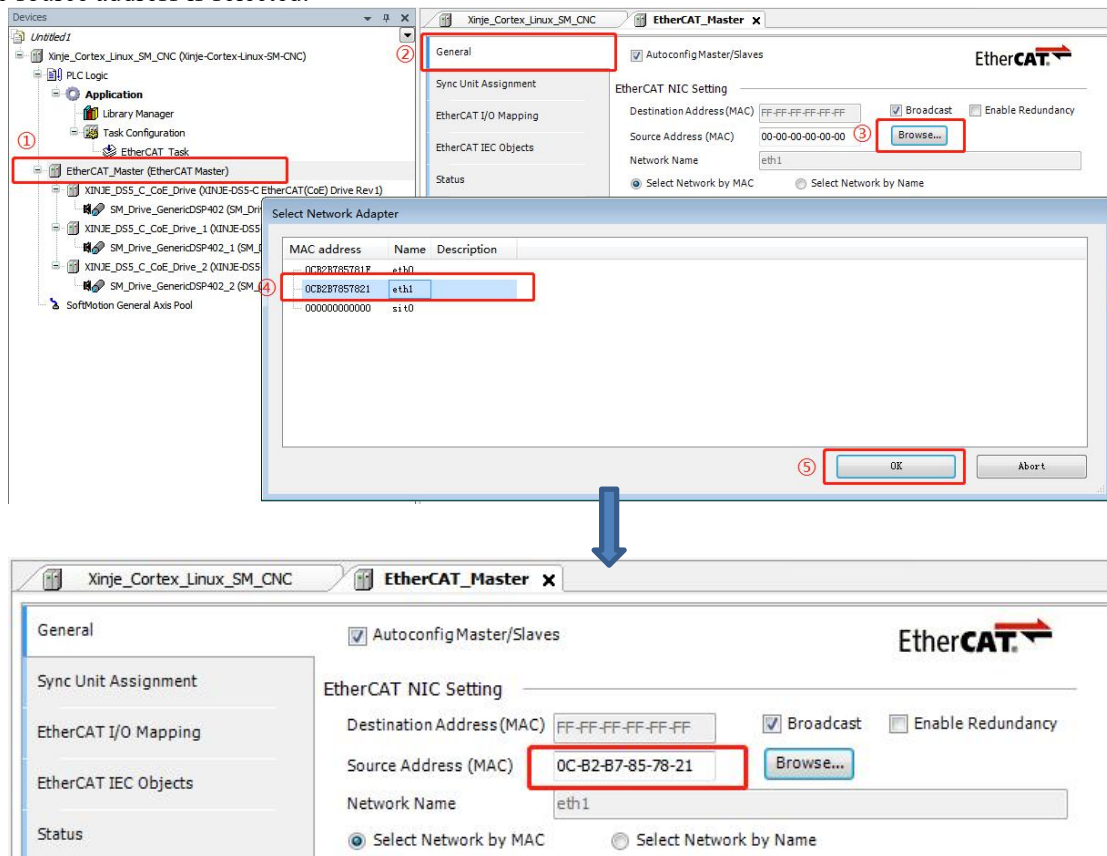

8) Make the program

Add POU. Right click application in the devices column and select Add object -- POU. Name the POU to be added and select the programming method, then click Add. In this example, the form of continuous function diagram (CFC) is selected for programming.

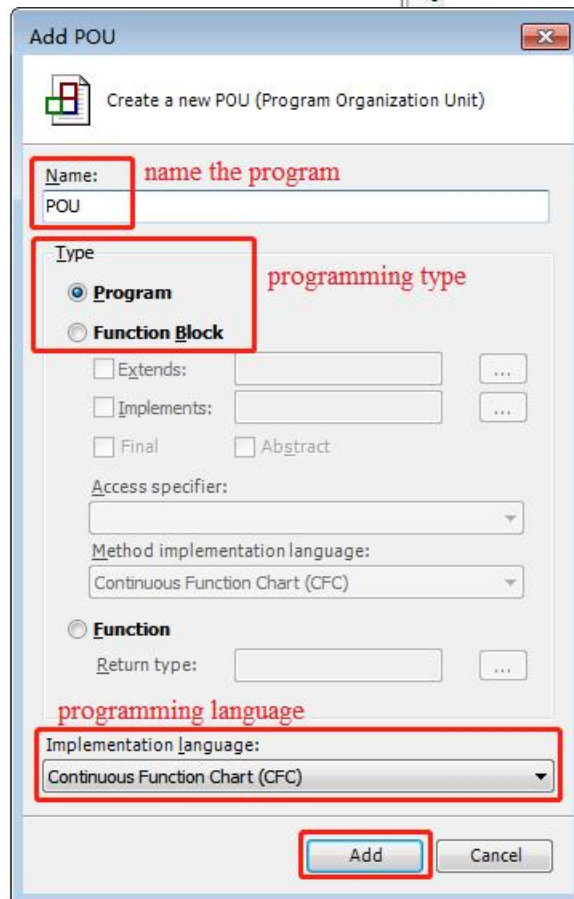
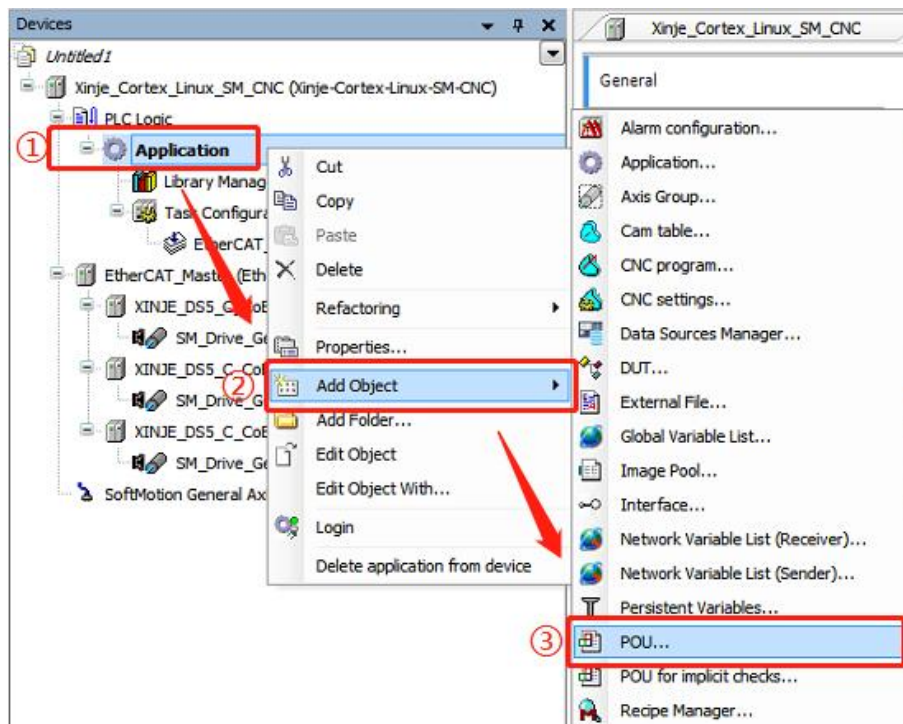

Double click the added POU to program in the POU interface.

Note: POU should be added to the task, because subsequent compilation commands only compile the programs added to the task. If the created POU is not added to the task, the compile command does not perform syntax check for the POU. Right click EtherCAT_ Task, select Add object -- Program call, fill in "POU" in the dialog box "Add Program Call", and finally click Add.

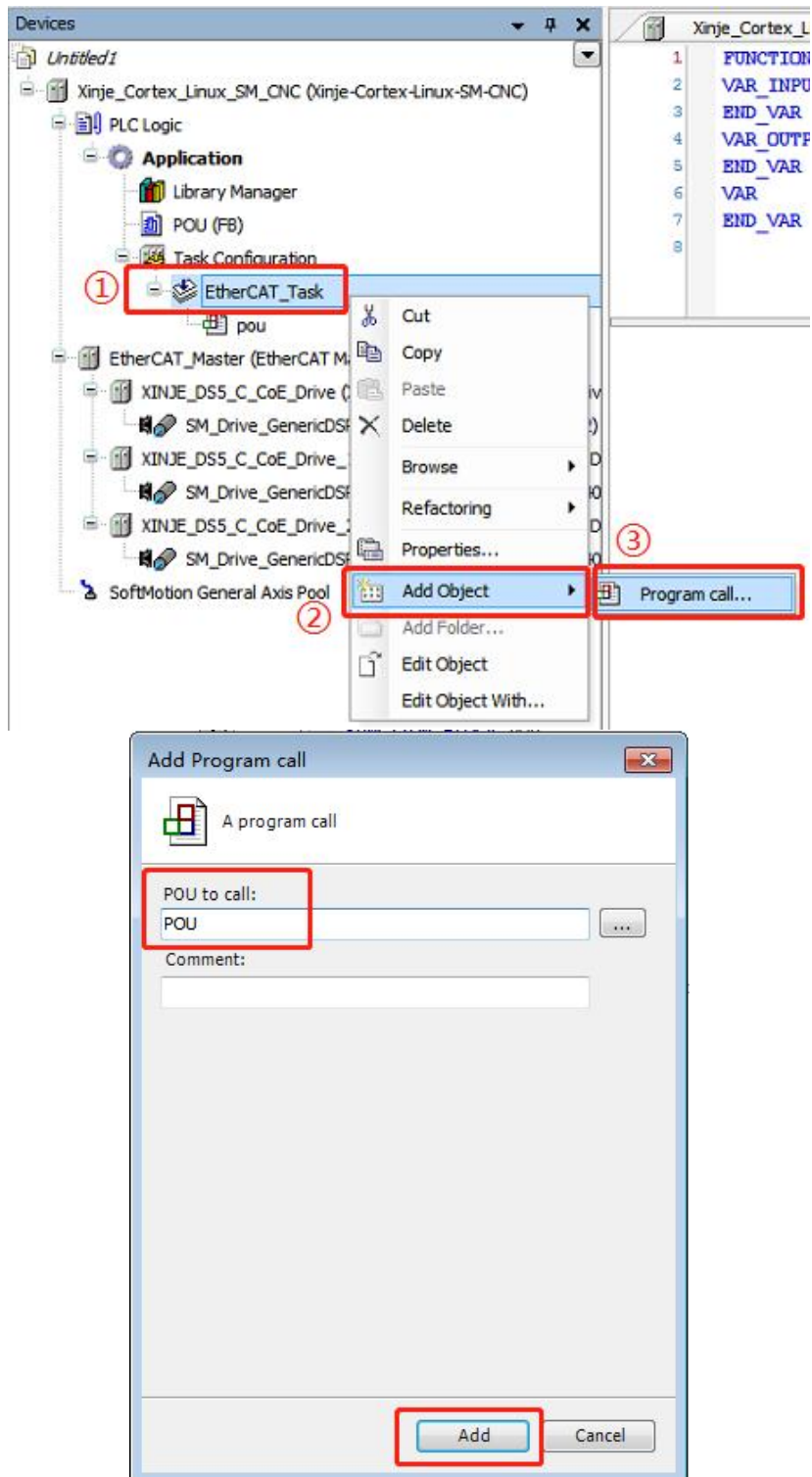

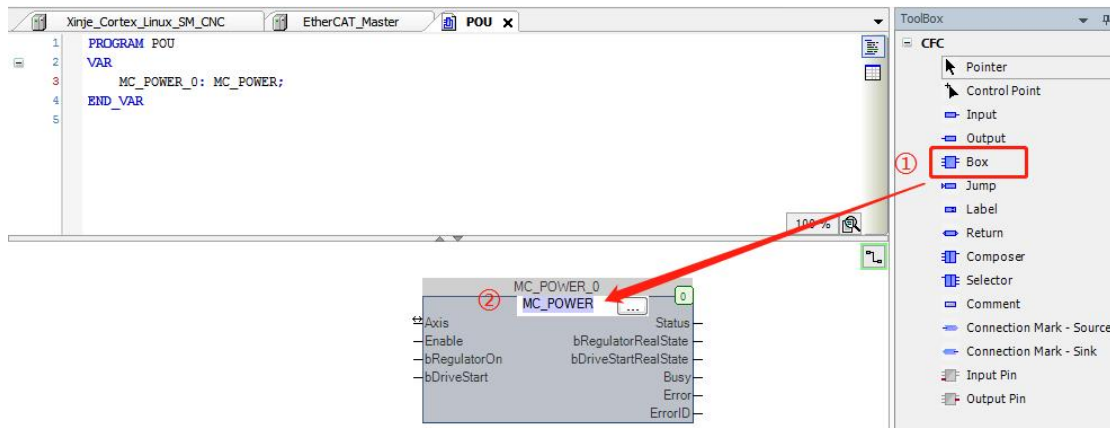

Call the function block

On the POU interface, calling an MC_POWER function block to control the axis enable. Select the box in the toolbar, drag it into the programming interface, and enter MC_POWER.

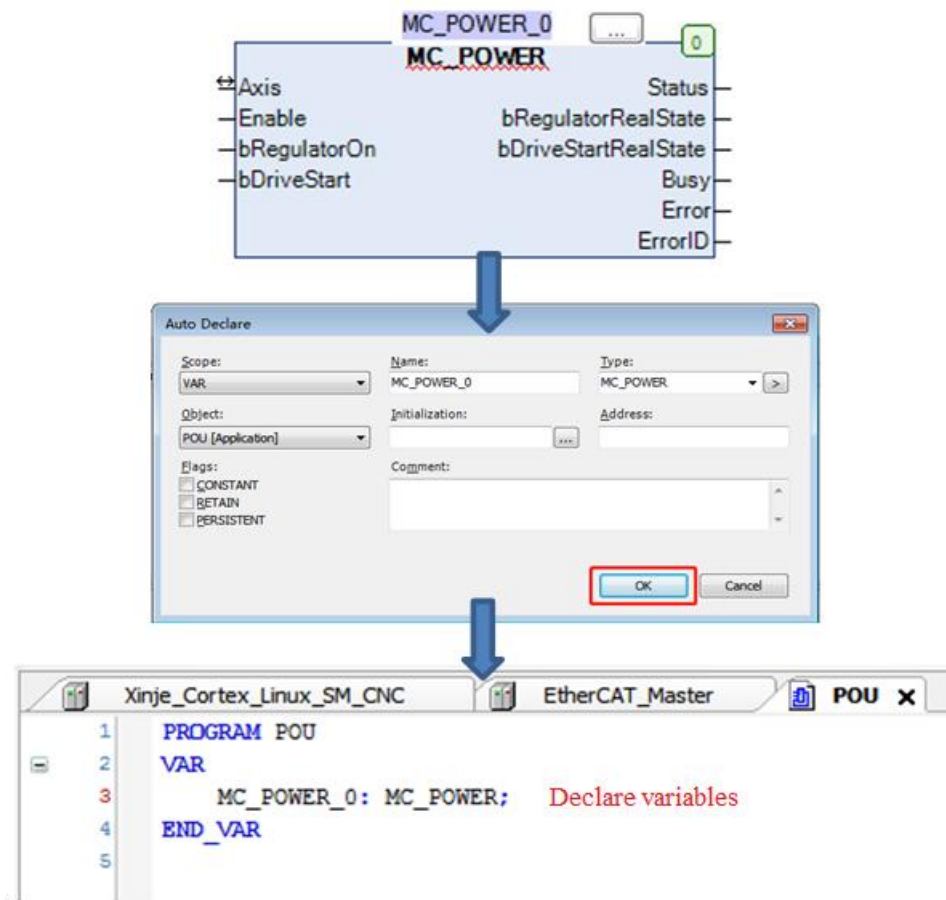

Link this function block to the variable of the first slave station axis, as shown in the figure, enter MC_POWER_0, the programming interface will automatically generate variables to be declared.



Add input and link the function block to the first slave station axis. Select Input, drag it in the programming interface, double click this object, click , select IoConfig_Globals-- SM_Drive_GenericDSP402 in the Input Assistant, click OK.

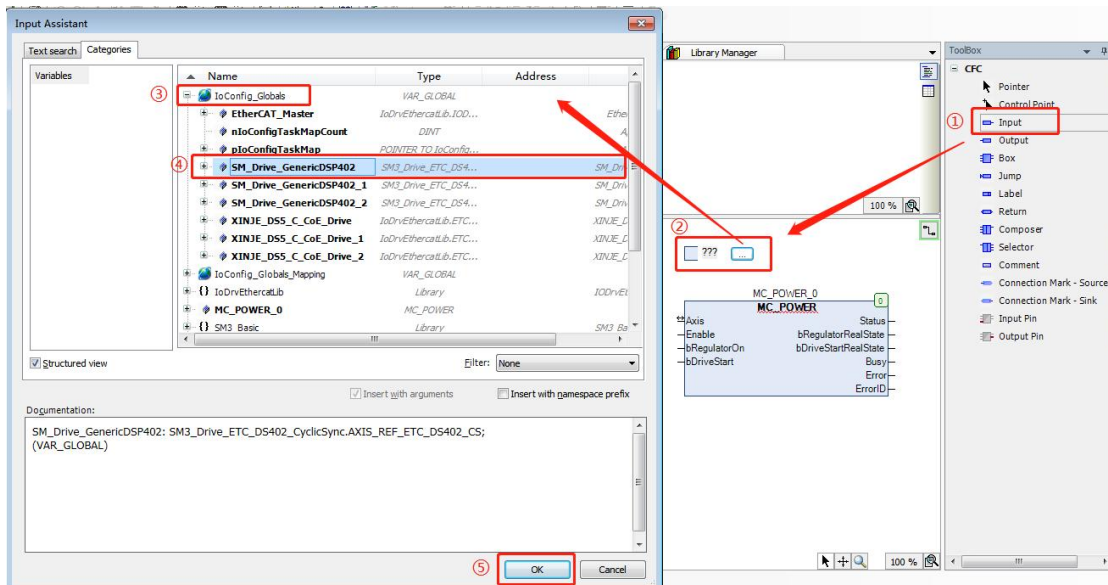

Connect the added input function block and the enable function block with wires.

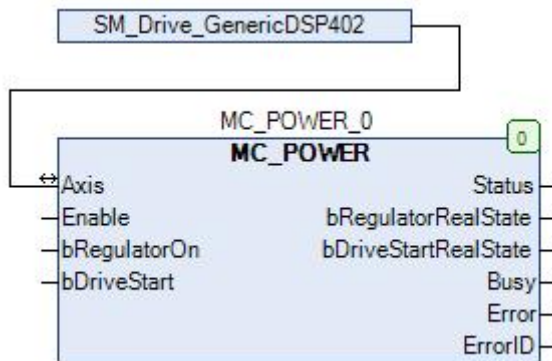

Similarly, continue to add the relative movement function block MC_MoveRelative, Stop function block MC_Stop, Reset function block MC_Reset. The procedure is shown in the figure below.

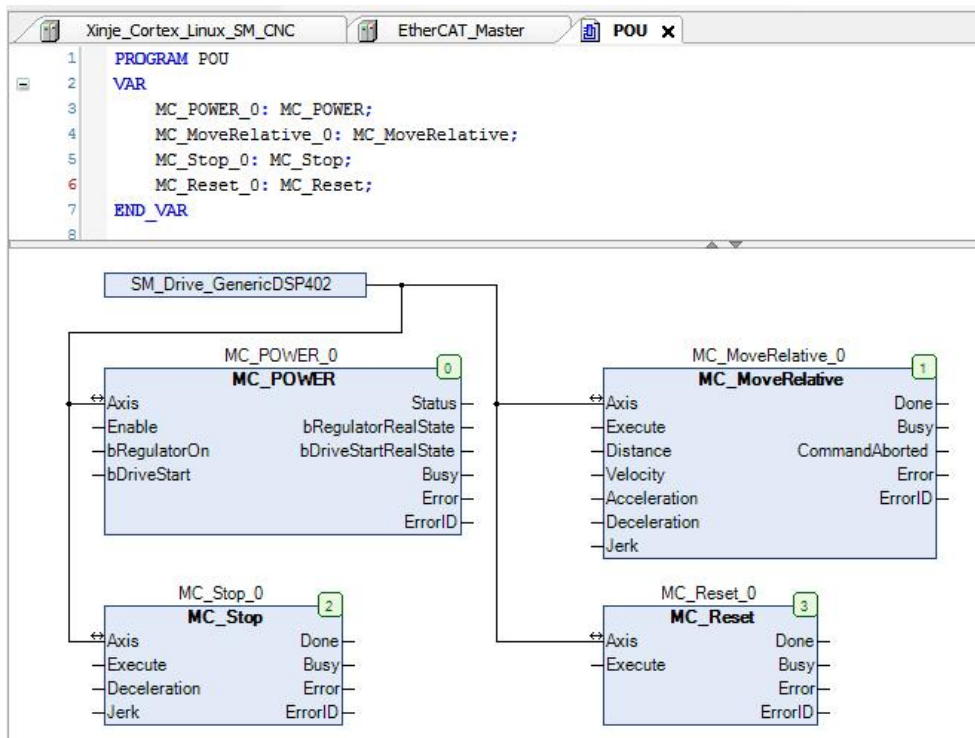

9) Add visualization

Right click application in the devices column and select Add object - visualization. After naming and selecting the programming method, click Add.

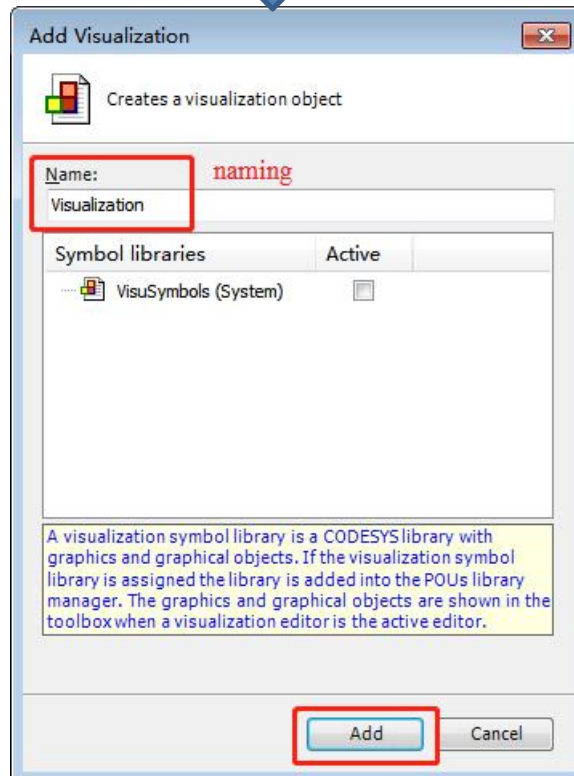
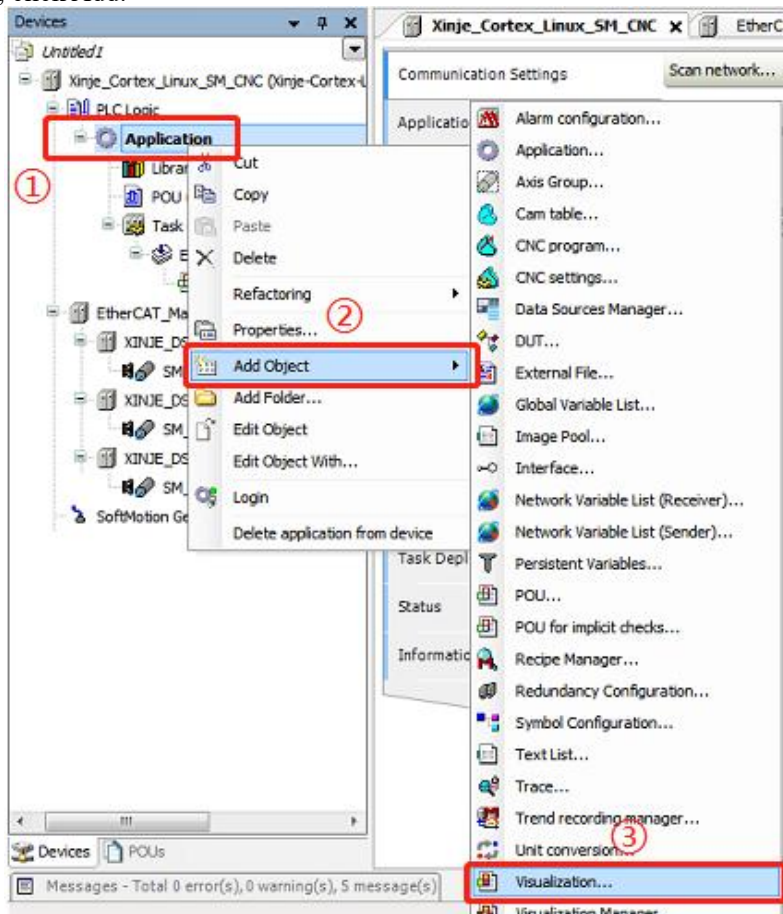

Double click visualization in the devices column to add the required visualization. For example, you can search

for power in the toolbar and drag the visualization object into the screen.

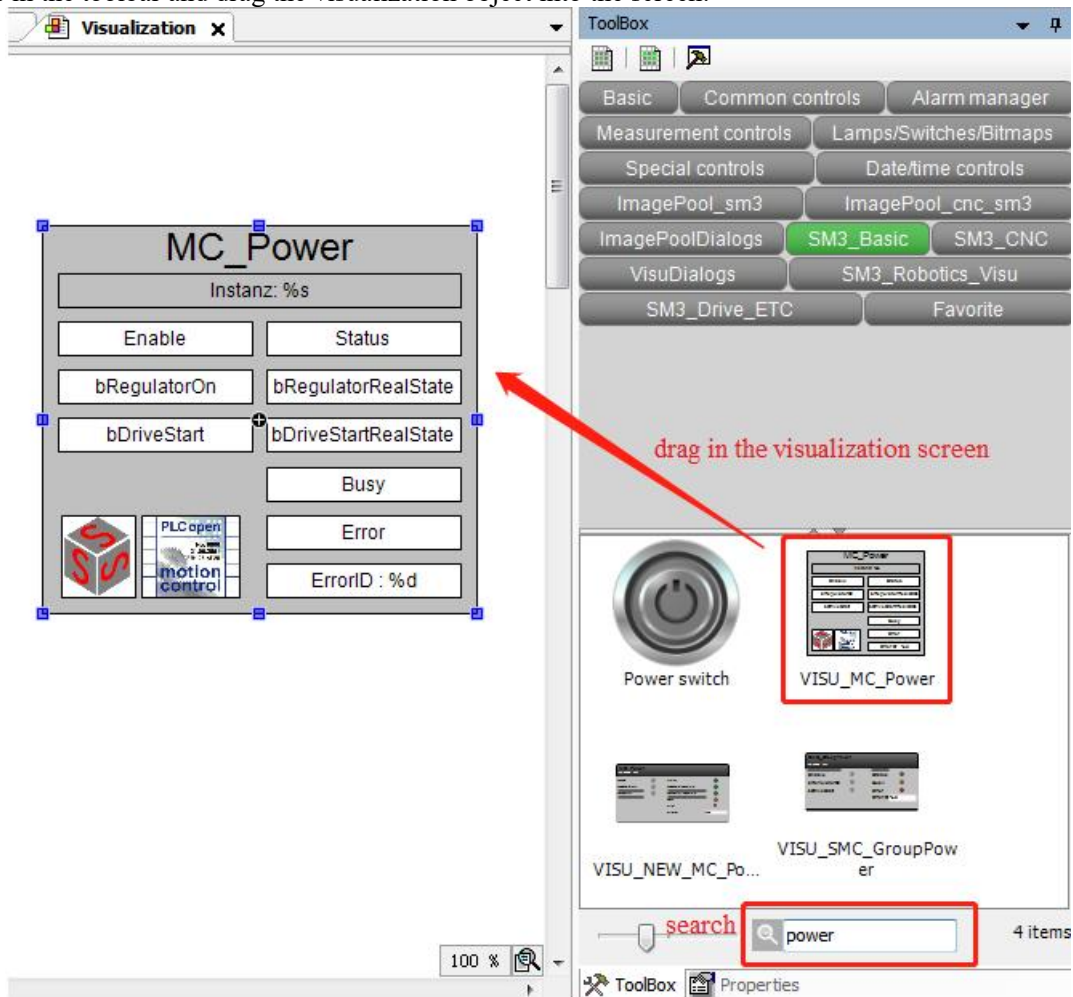

When you drag the control object into the editing area, the dialog box Assign parameters < VISU_MC_Power> will pop up automatically, link the control object to the corresponding declared variable. Double click the value column.

Click , at this time, select the declared variable in the newly pop-up dialog box, and then click OK. The linked variable name will appear in the value column. Finally, click OK, that is, the variable linking is completed. Similarly, other control object follow suit.

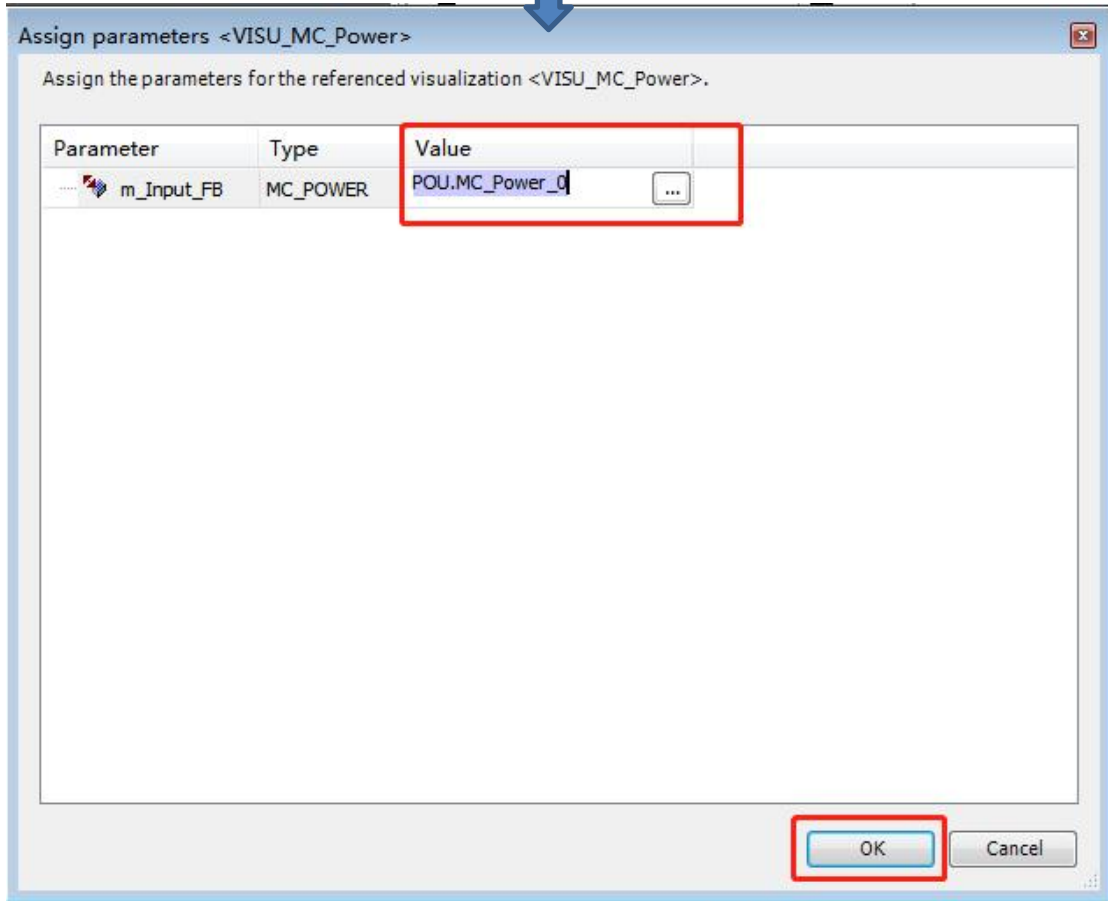
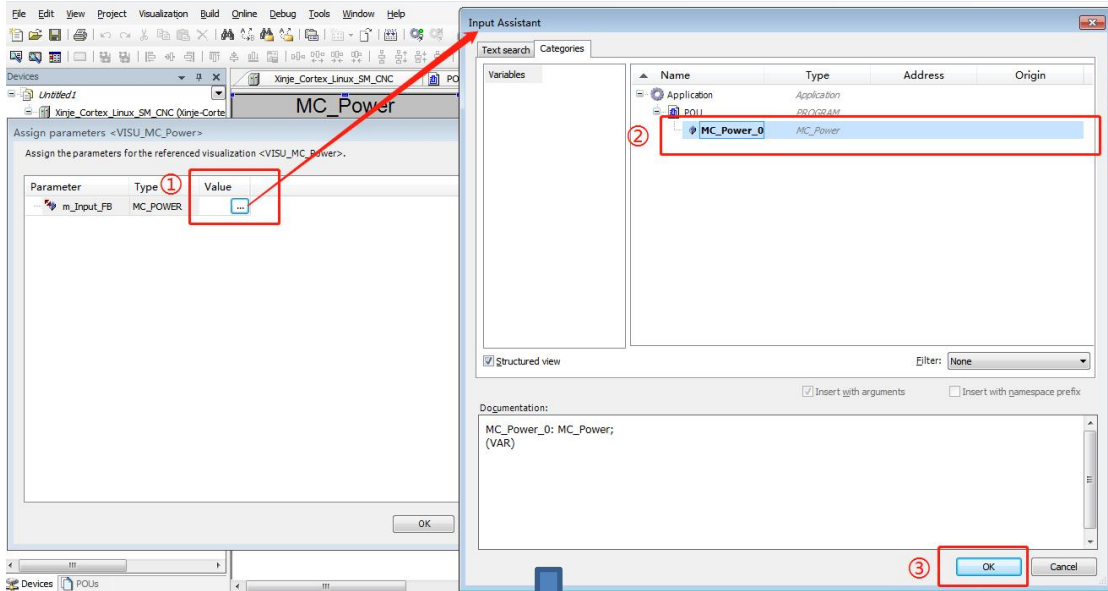

Add an object that simulates the rotation of the motor and link it to the motor axis. Add it in the same way as above.

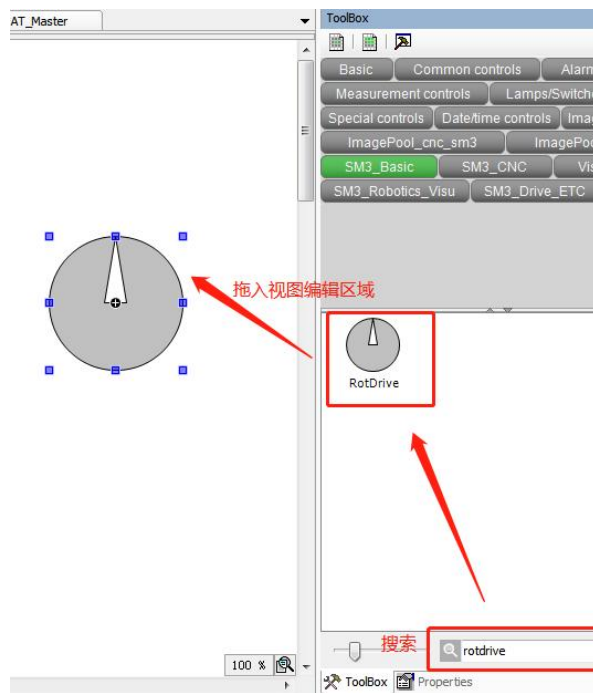

The created view is as follows:

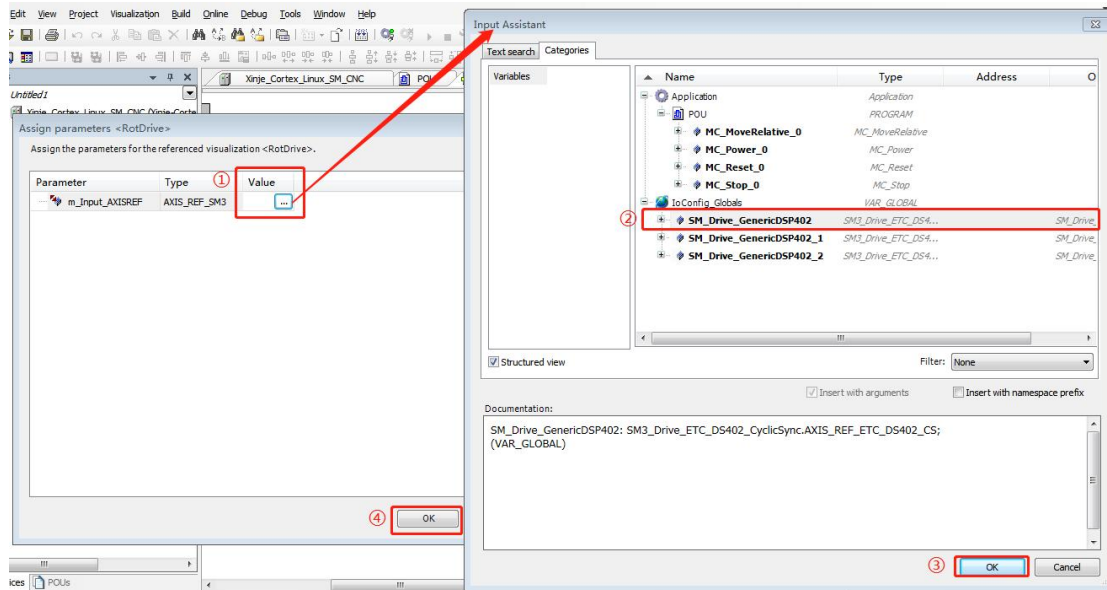

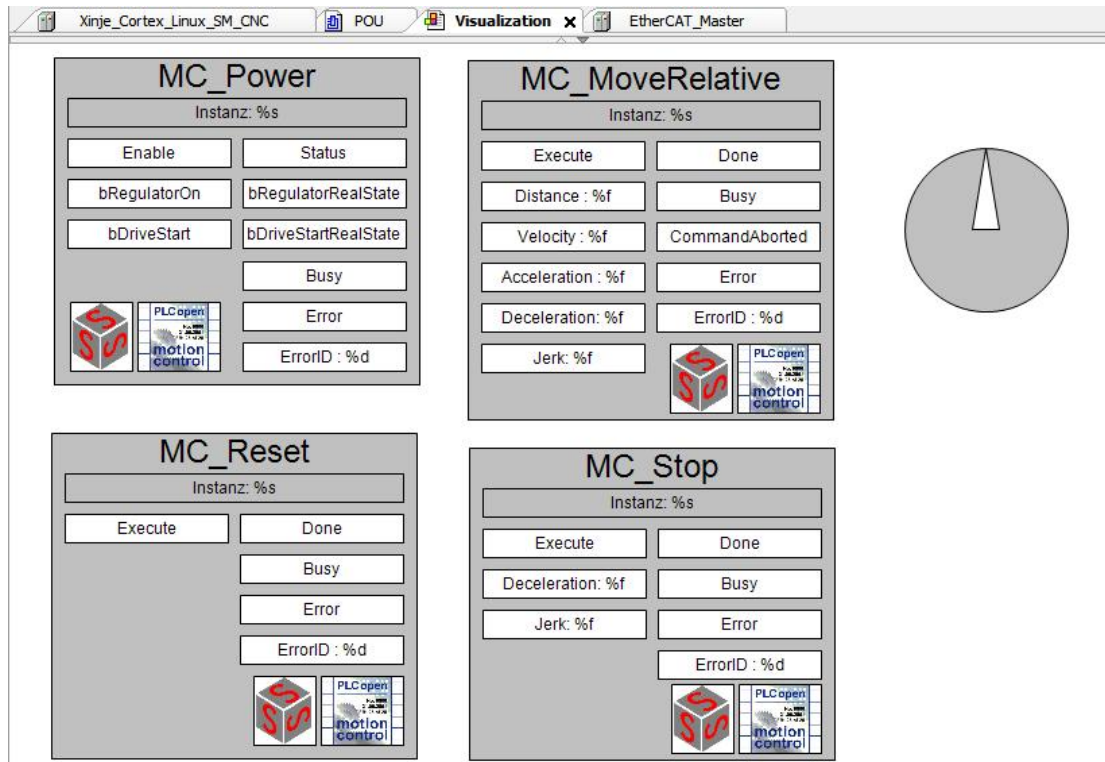

10) Online control

Parameter setting of axis. Double click axis 1 to set axis parameters in the Scaling/Mapping tab. ① To set the encoder accuracy, a 17-bit encoder is connected in this example, so 131072 is filled in.

The relationship between settings and output: coefficient = $(4 * 5 * 6) / (2 * 3)$

Example: when the input-output relationship coefficient is 10, the distance in the MC_MoveRelative function block is set to 100, then $100/10 * 131072 = 1310720$, that is, the set operating distance is 1310720 pulses, and the motor will rotate for 10 revolutions.

At this time, set the velocity value in the function block to 10, then $10/10 * 131072 = 131072$, that is, the motor will run at the speed of 131072/s.

Set the acceleration value to 1000, then $1000/10 * 131072 = 13107200$, that is, the acceleration of the motor is $13107200/s^2$, the deceleration setting is the same.

axis parameter settings

Scaling/Mapping

Scaling

Invert direction

131072 ① increments <=> motor turns ④ 1

1 ② motor turns <=> gear output turns ⑤ 10

1 ③ gear output turns <=> units in application ⑥ 1

Mapping



Automatic mapping

Cyclic object	Object number	Address	Type
status word (in.wStatusWord)	16#6041:16#00	%IWO'	'UINT'
actual position (diActPosition)	16#6064:16#00	%ID1'	'DINT'
actual velocity (diActVelocity)	16#606C:16#00	%ID2'	'DINT'
actual torque (wActTorque)	16#6077:16#00	%IW6'	'INT'
Modes of operation display (OP)	16#6061:16#00	%IB14'	'SINT'
digital inputs (in.dwDigitalInputs)	16#60FD:16#00		
Touch Probe Status	16#60B9:16#00		
Touch Probe 1 rising edge	16#60BA:16#00		
Touch Probe 1 falling edge	16#60BB:16#00		

Inputs:

Outputs:

After setting parameters, compile the program for syntax check, and log in and run the program after no error is reported. Login enables the application to establish a connection with the target device and enter the online state. The precondition for correct login is to correctly configure the communication settings of the device and the application must be free of compilation errors.

Execute  compile,  login,  run, the normal operation status is shown in the figure below:

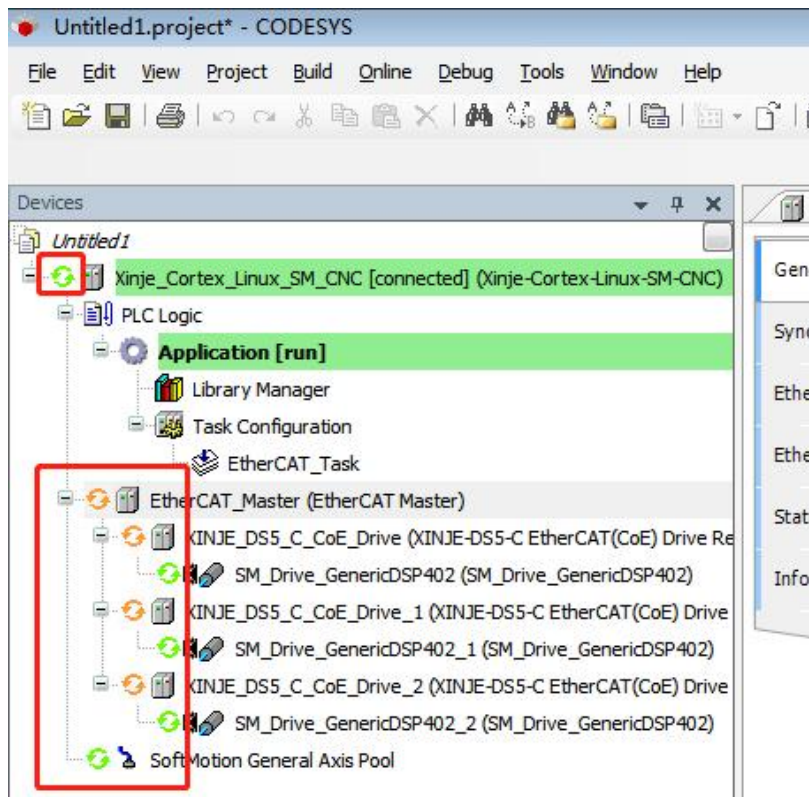

At this time, the distance, speed and other parameters that the motor needs to move can be set in the visualization. Click bDriveStart—bRegulatorOn—Enable in turn in the MC_Power function block to enable the motor normally. Finally, click Execute in MC_MoveRelative function block to start relative position movement.

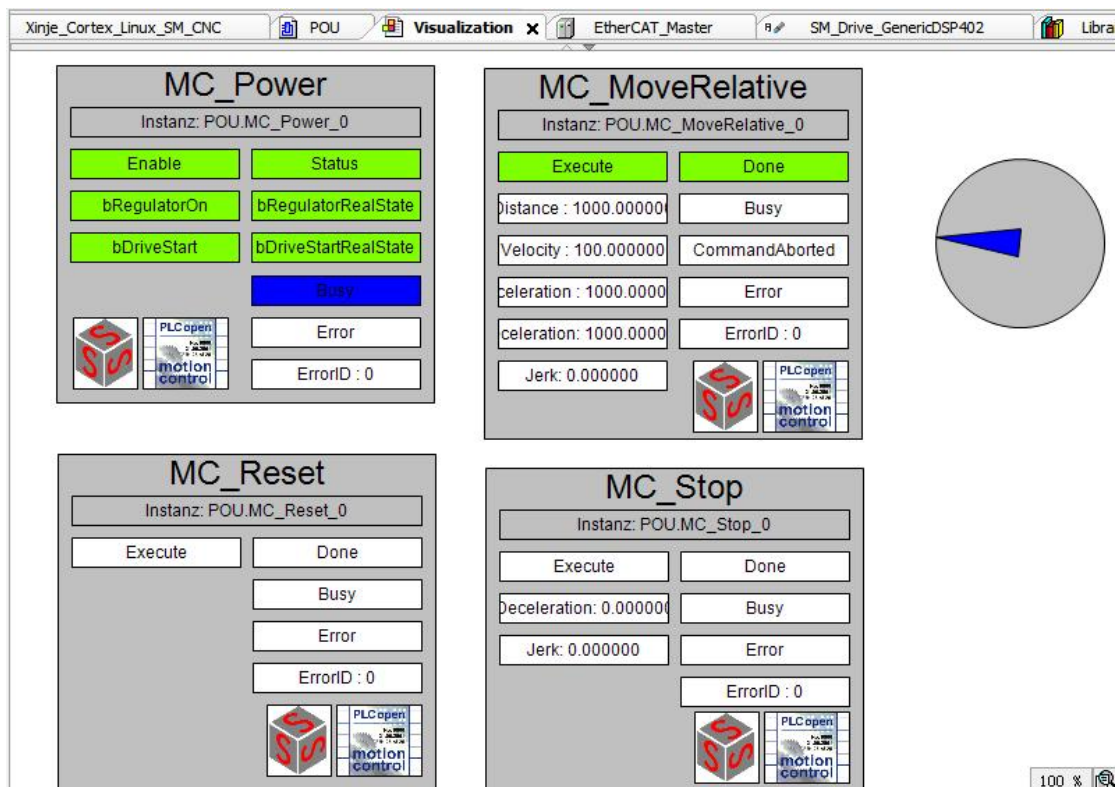

11.4 OMRON and DS5C1 servo Ethercat communication example

This example will explain how Omron PLC is used as EtherCAT master station and Xinje servo is used as slave station to realize EtherCAT motion control.

11.4.1 System configuration

Name	Model	Quantity	Note
Upper computer	Sysmac Studio	1	Omron software
Controller	OMRON NJ501-1500 series	1	
Xinje servo	DS5C1-20P4-PTA	1	
Network cable	JC-CA-3	Some	Used for connection between computer and PLC or between PLC and servo

11.4.2 System topology

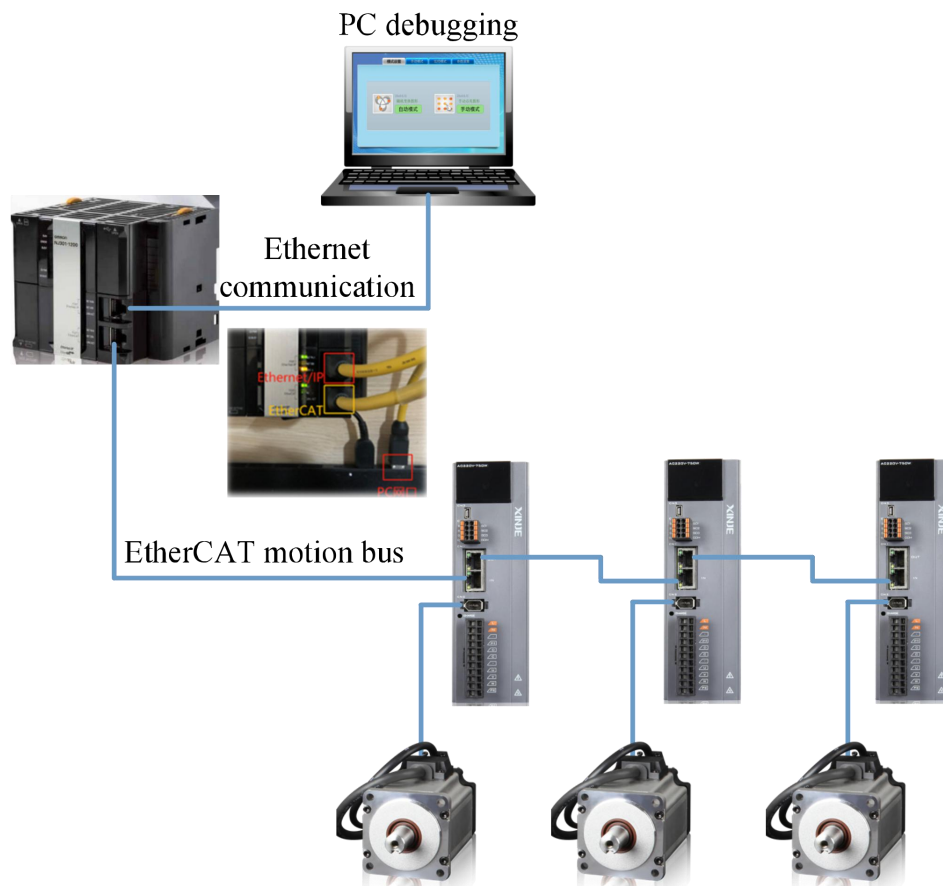

The NJ501 CPU module has two network ports, the red marked is Ethernet/IP, which are used to connect the Omron host computer SYSMAC studio to monitor and write data to the PLC. The yellow marked is EtherCAT, and the other end is connected to Xinje DS5C1 series servo to realize EtherCAT communication.

Each network port is equipped with three indicators, RUN/ERROR/ACT. After the network cable is correctly connected, RUN should be on and ACT should be on. When the communication is established and there is data interaction at the network interface, ACT flashes. Error will not light up unless it is abnormal.

11.4.3 Debugging steps

1) New project

If "new project" is selected for the first time, select model: NJ501-1500, version 1.02 in the project attribute interface, and click "create" to generate the programming interface.

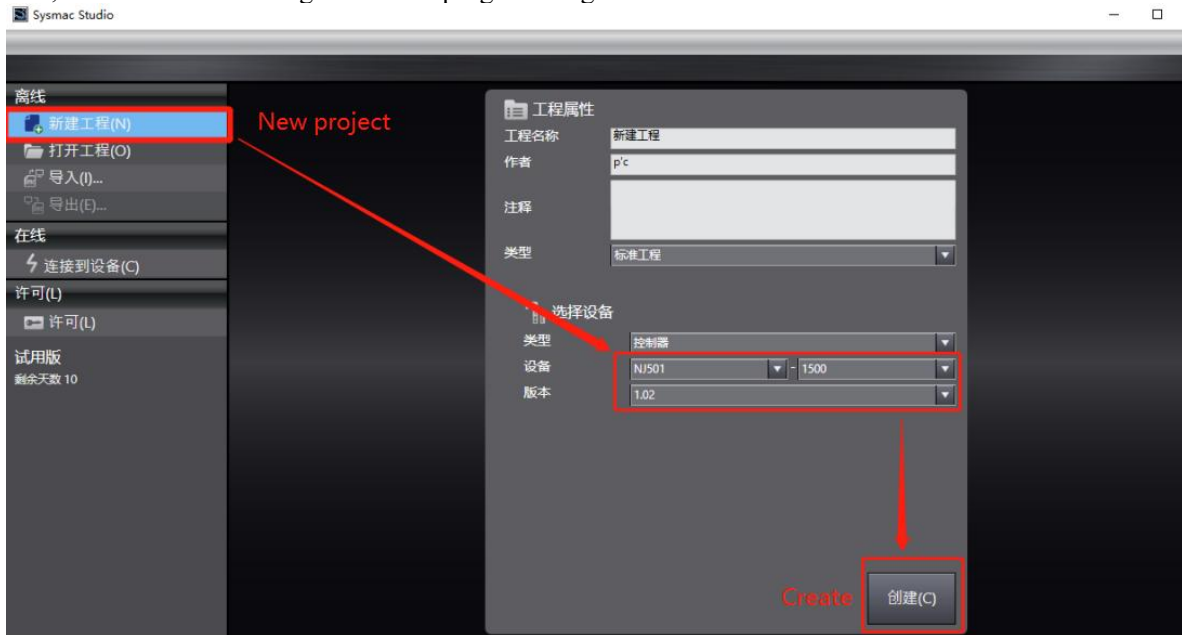

2) Add XML file

Double click "EtherCAT" on the main interface to call up the EtherCAT configuration interface. For the first time, you need to add XML files to the library. Right click "master device" and select "display ESI library".

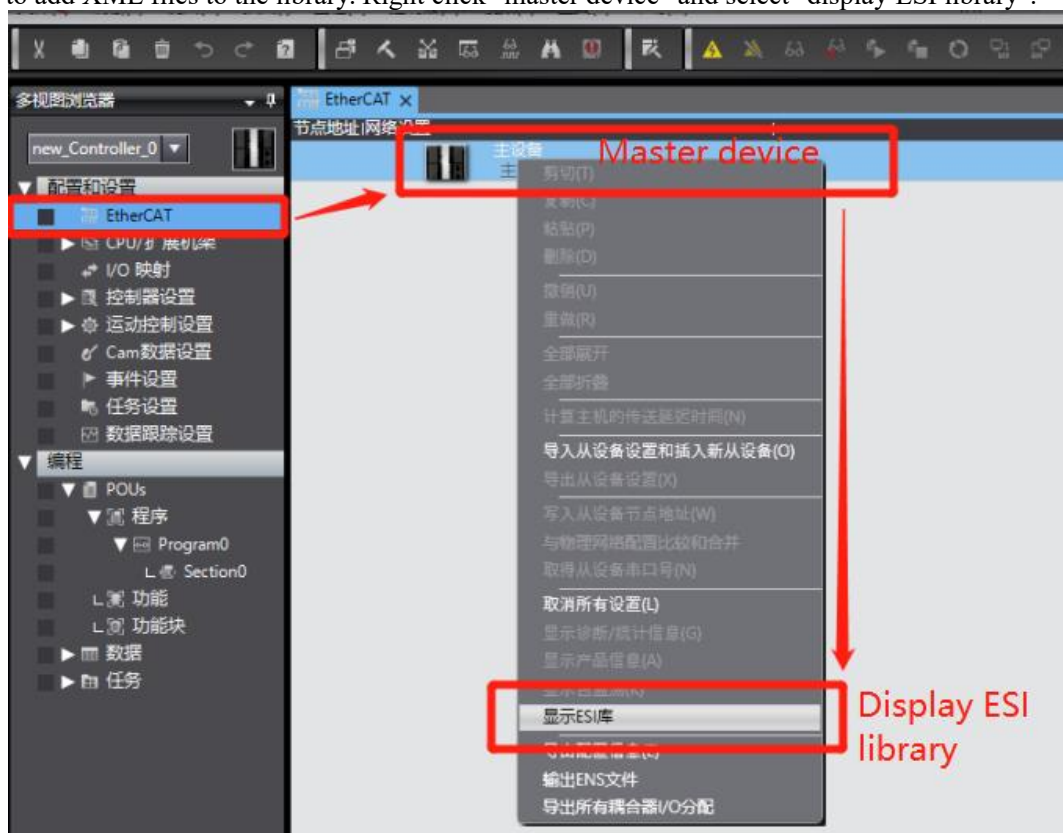

Then we need to add the XML file of DS5C1 to the pop-up ESI library. Select "this folder" to display the path of the storage folder, and put the "Xinje-DS5C-rev1.1" XML type file in the path folder.

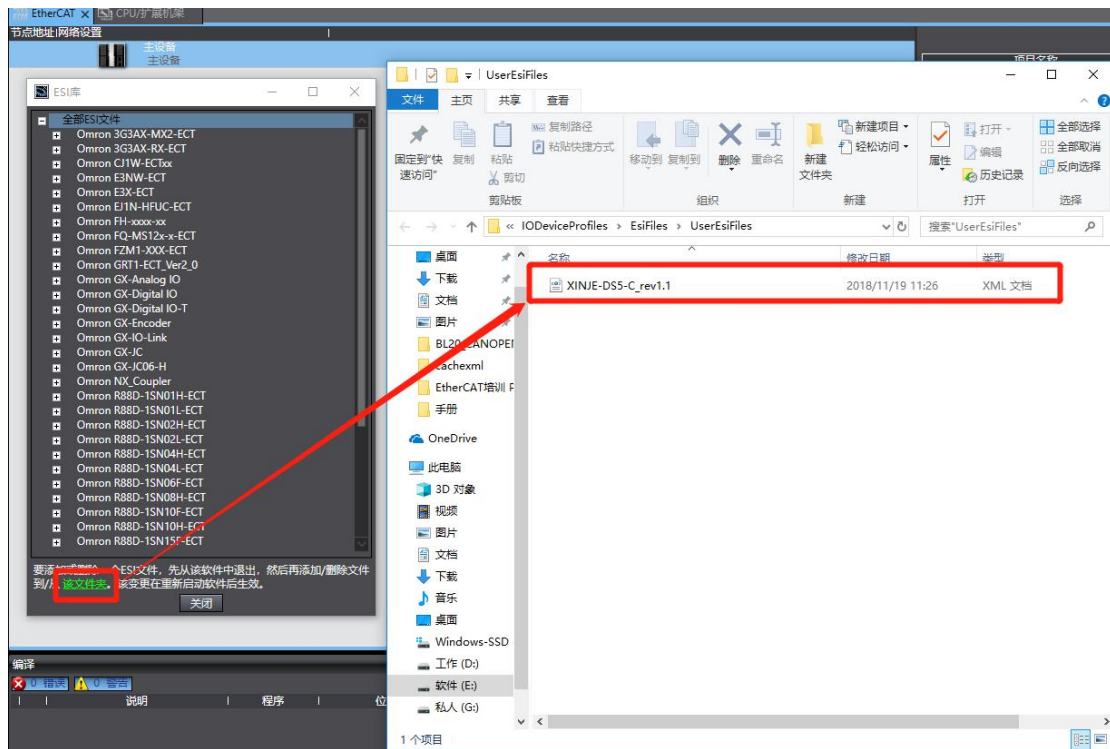

Finally, close SYSMAC studio and restart the software, browse the "ESI library" again, and the Xinje-DS5C slave station description file already exists in the library.

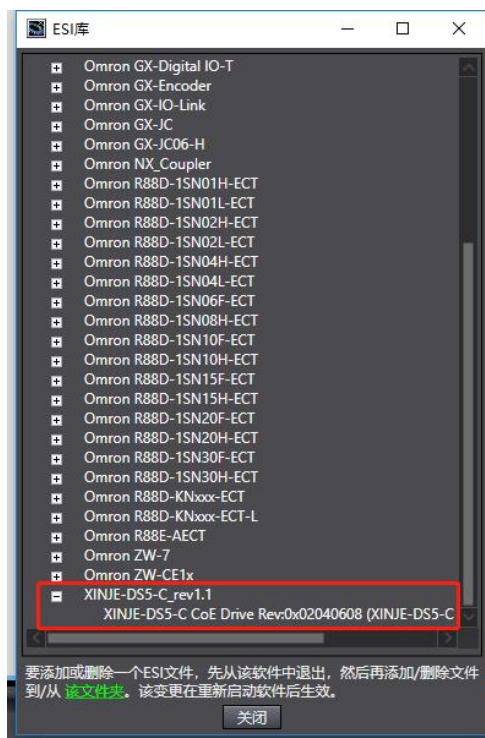

3) Add device

Find "XINJE-DS5C CoE Drive Rev" on the right side of the interface, double click it to add to the node under master device.

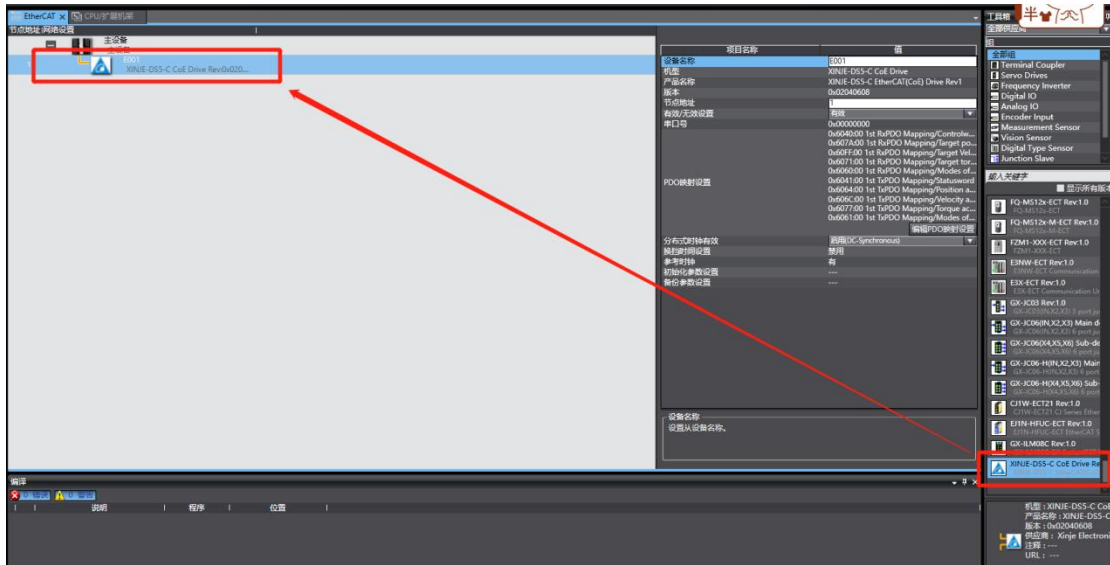

After adding a node, select the node with the cursor to display the PDO configuration of the current node. Select Edit PDO mapping settings. The pop-up interface will display the current output PDO mapping on the left and the PDO items on the right. You can add or delete PDO as required.

Select "add PDO item" to add PDO, and the pop-up window will show the PDO objects that can be added. After selecting, click "OK", and then click "apply", and the addition is successful.

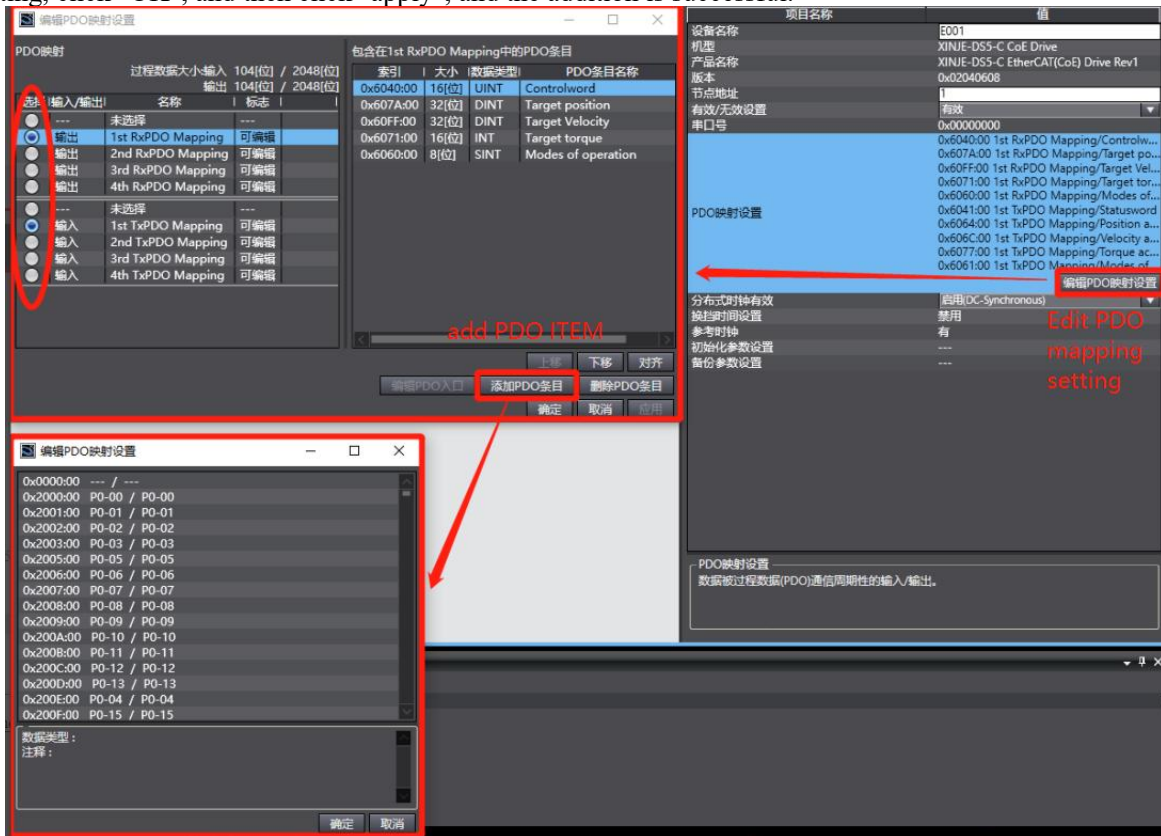

After adding, it is shown in the following figure:

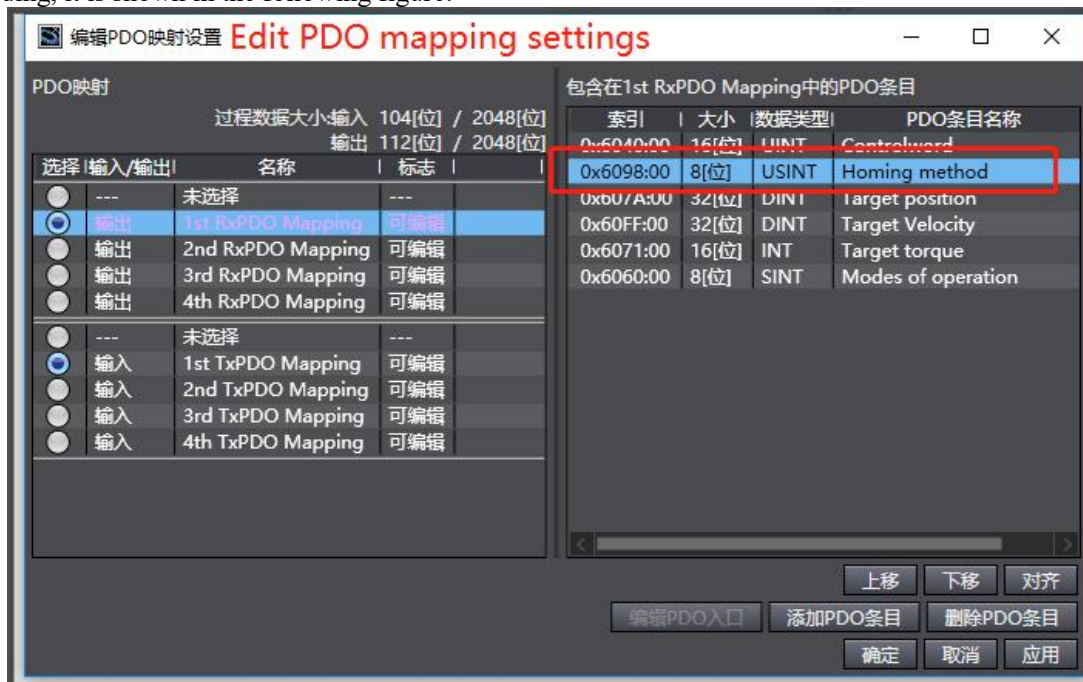

4) Motion control axis settings

Double click "motion control settings", right-click "axis settings", and select "add - motion control axis".

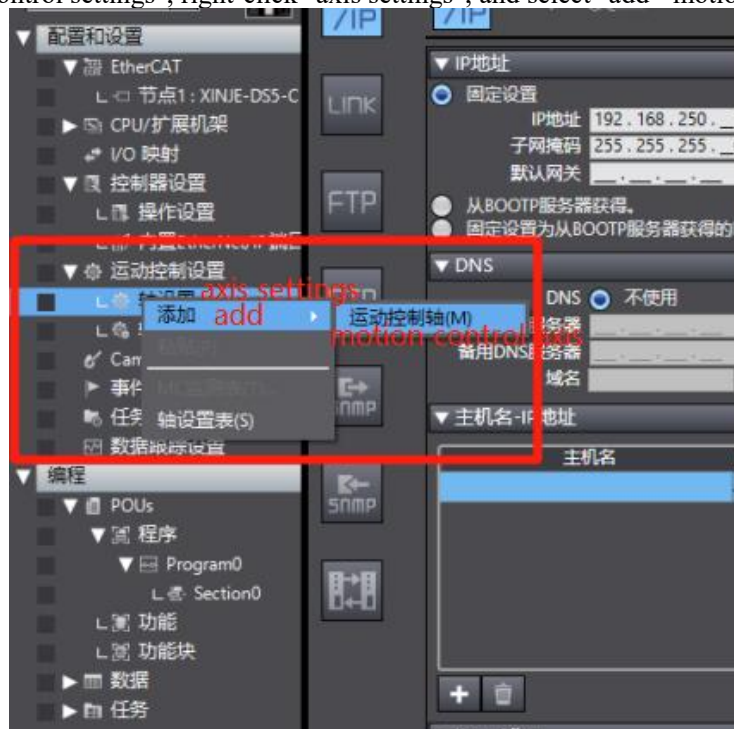

Double click " MC_Axis000" to display the axis setting interface. The interface is divided into multiple sub interfaces.

Select "axis type - servo axis" in the "axis basic settings" interface, and select "node 1: DS5C" in the "input device".



Click detailed settings, expand the configuration module. The function name needs to be mapped to the PDO mapping item on the device. It needs to be added manually here. Missing or wrong addition will affect the subsequent use of this parameter.

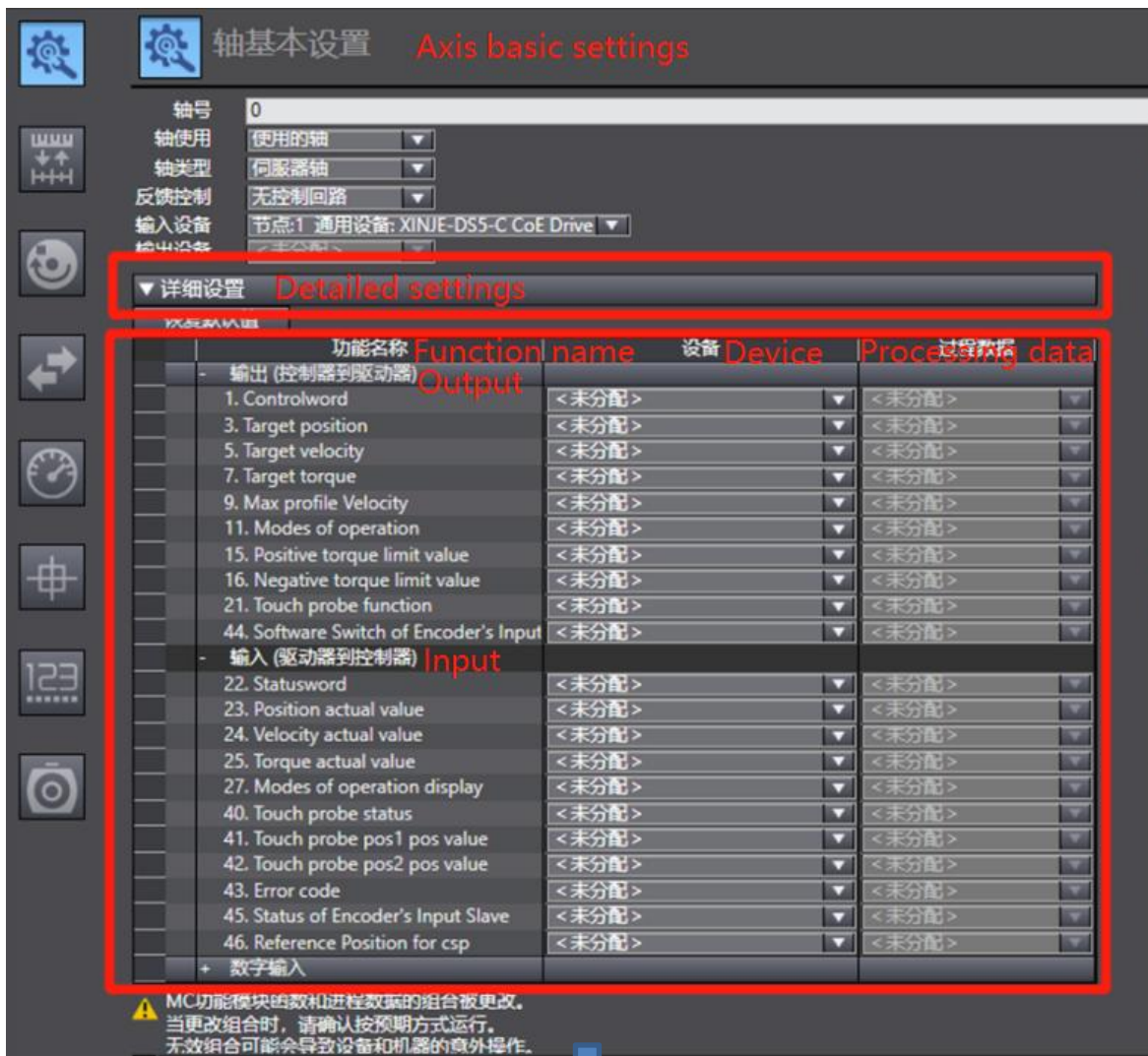

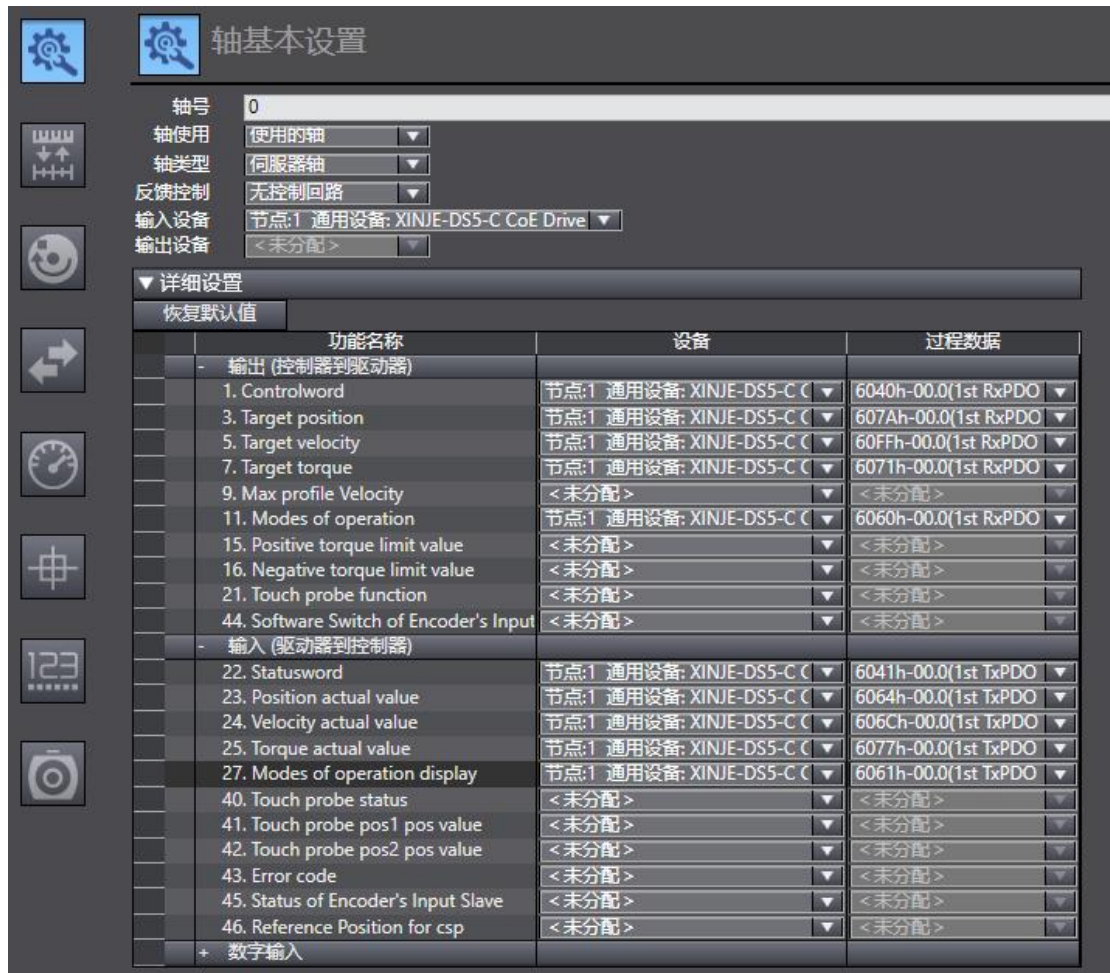

In "unit conversion setting", the number of motor encoder lines is correctly filled in the "number of command pulses per motor revolution". If 17-bit encoder is used in this example, it is modified to 131072. "Working stroke of motor for one revolution" is the equivalent stroke of motor for one revolution. The example here is modified to 131072, and the default gear ratio is 1:1.

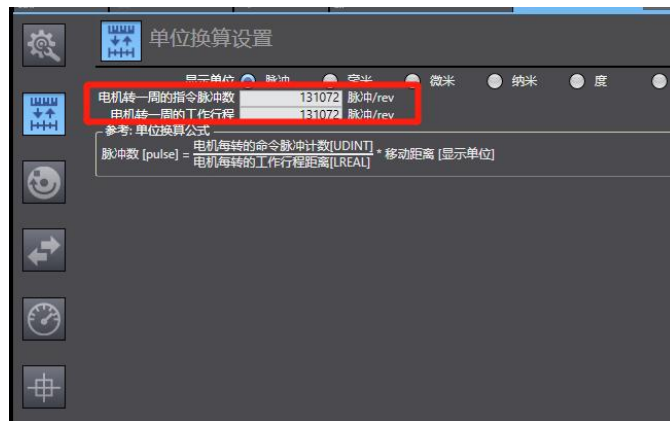

5) Write "round trip" program

Description of programming interface: select "programming / POU's / program / program0/ section0" and double-click "section0" to show the programming interface. By default, program0 is ladder programming. If ST programming is selected, right click "program / add / ST". The "toolbox" allows you to add various ladder elements.

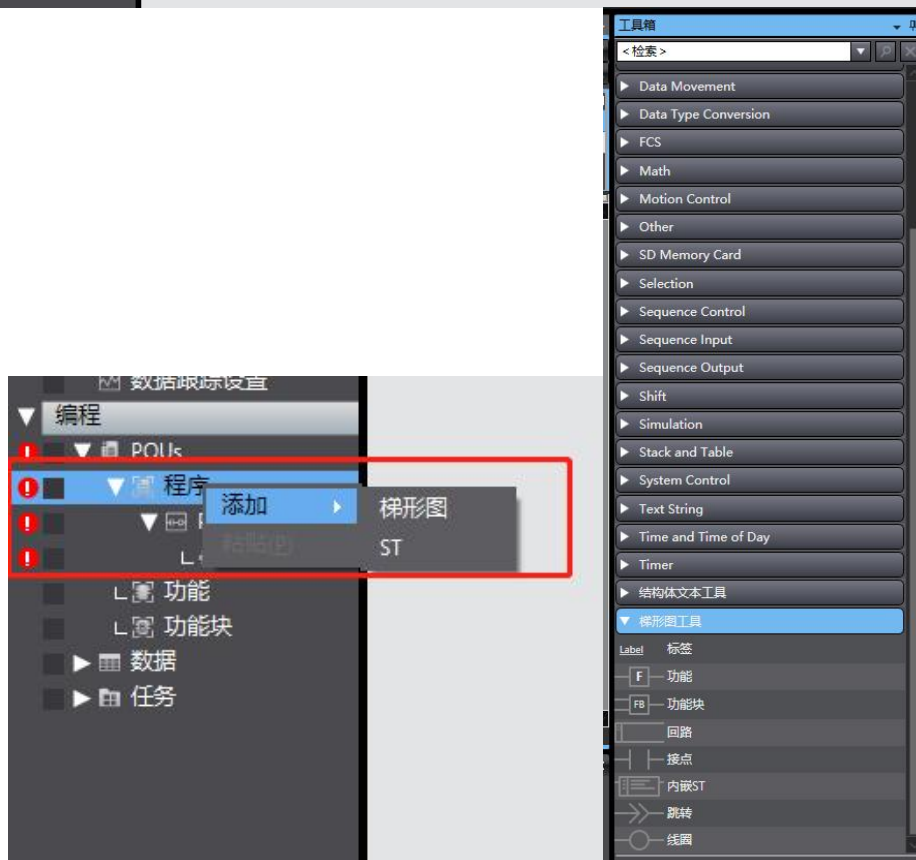
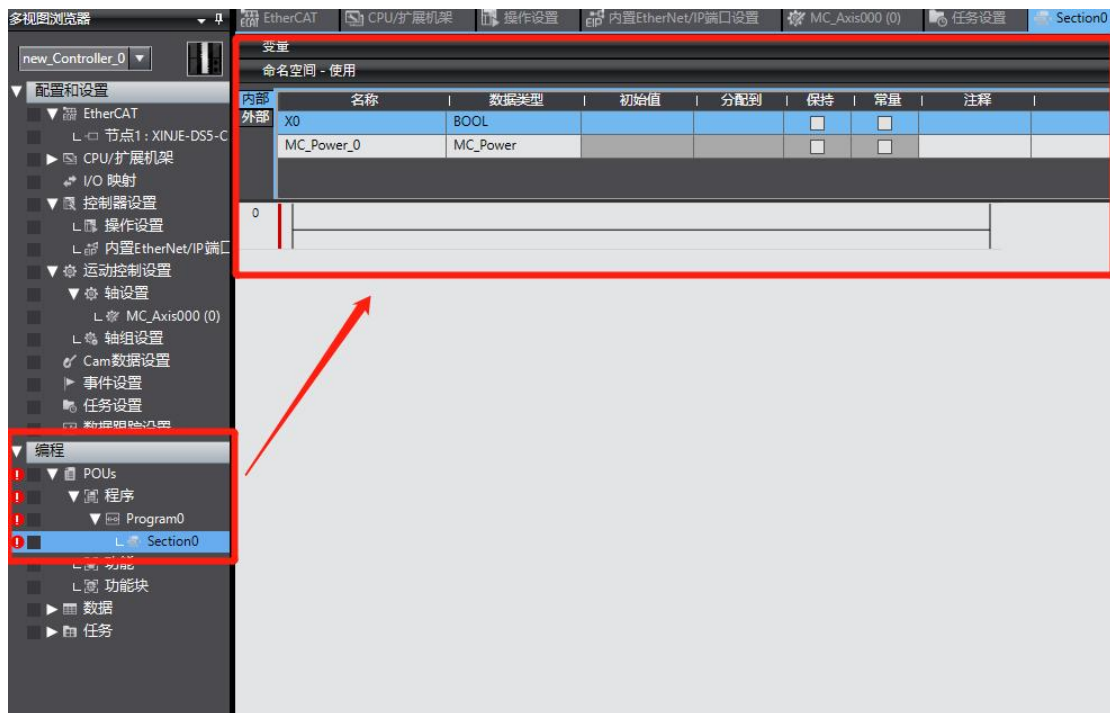

Select "contact" and drag it directly into the ladder node.

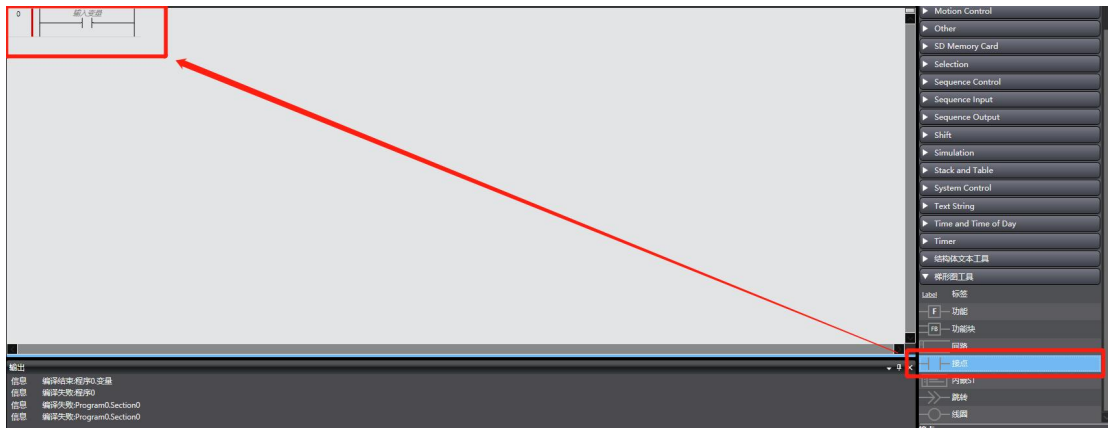

Click "input variable" to write the variable name. If it is a new variable name, a new variable will be generated. If it is an existing variable, you can directly select a variable to fill in. New variables can be viewed in the variable table. Right click variable X0 and select "jump to variable table" to expand the variable table. In the variable table, you can create variables of various data types for calling, or view all variables that have been defined.

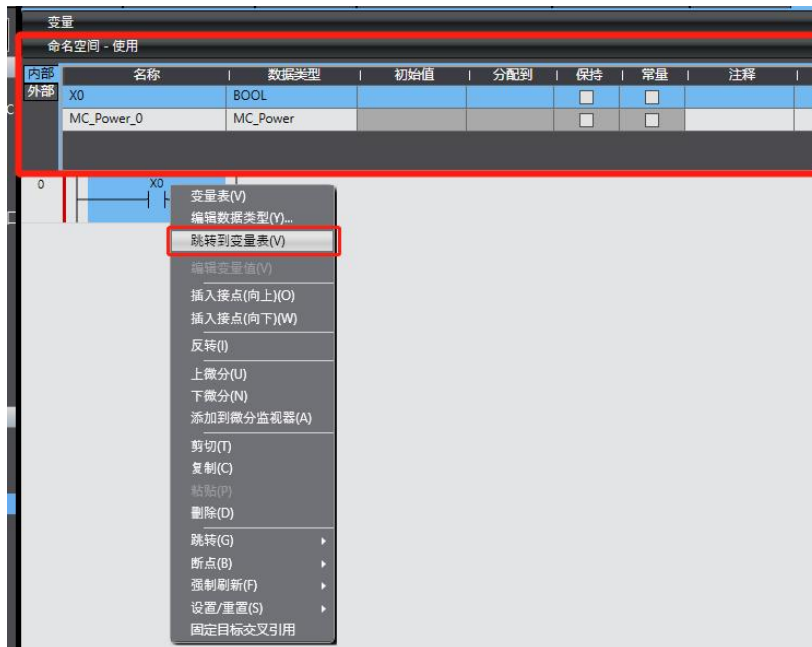

Add a "function block" in the same way as in the ladder diagram.

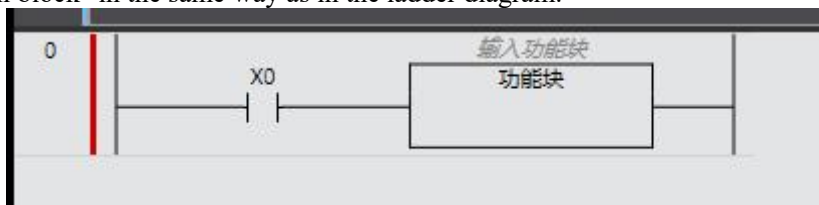

Enter a function block name to call this function block parameter. If "MC_Power" is input, the calling function block is declared as MC Power.

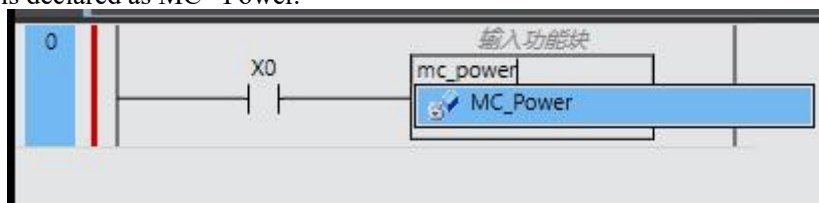

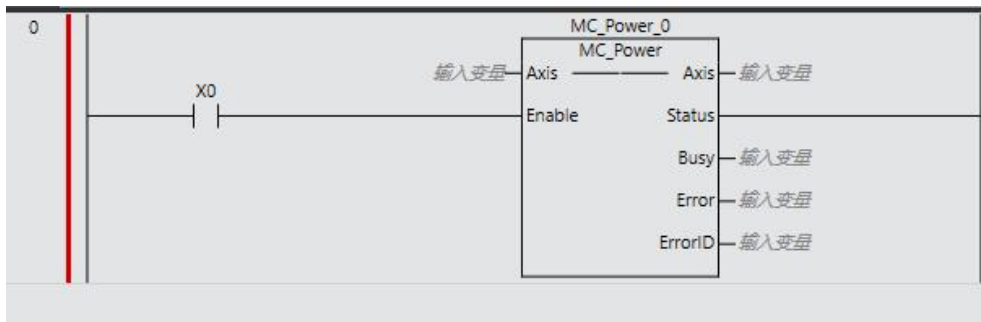

Function block "Axis" pin connected variable, input MC_Axis000 indicates that the function block is applied to the axis "MC Axis000".



Add function block "MC_MoveAbsolute" in the same way, and define the variable name for the pins "Position" "Velocity" "Acceleration" "Deceleration" to "Pos_1" "Vel_1" "Acc_1" "Dec_1".

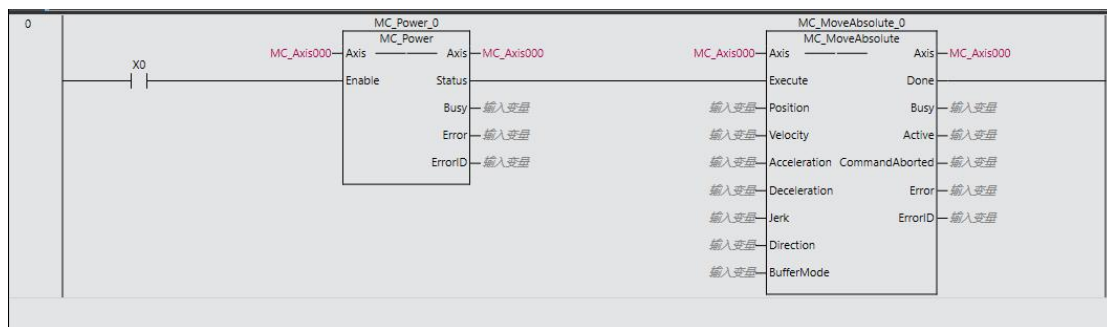

The defined variables can be written with initial values in the variable table, and the initial values take effect when the PLC is running.

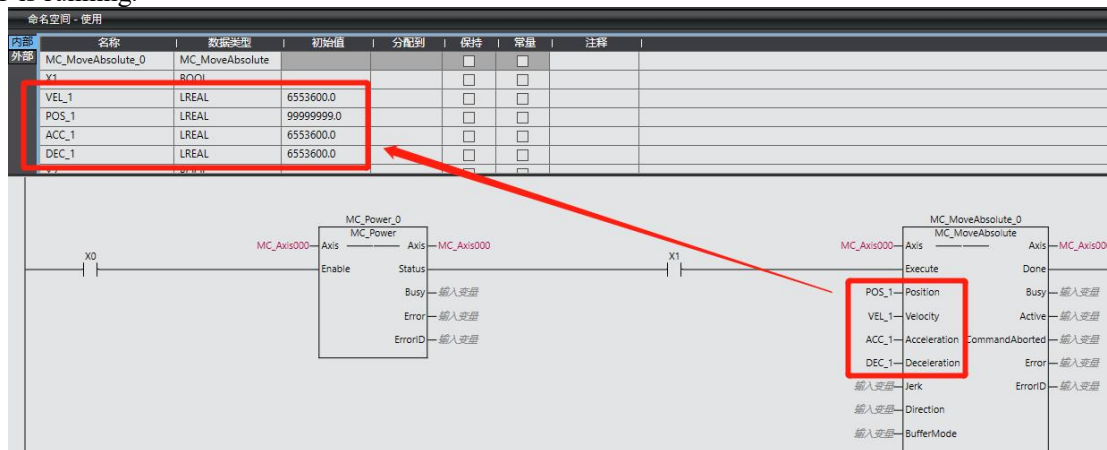

The same way to write a complete round-trip motion ladder program.

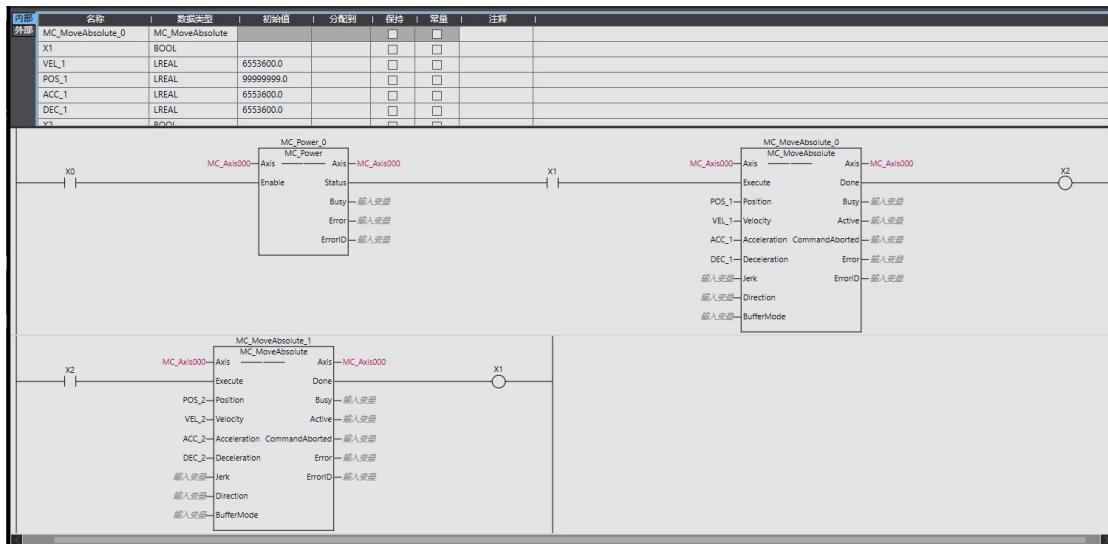

6) Gateway communication settings

First, check the IP address of the PLC: in the multiview browser, select "controller settings - built-in Ethernet / IP port settings" to show the "TCP / IP settings" interface on the right. The fixed IP address setting of the current project can be viewed in the configuration interface. For a new program, the default IP address is 192.168.250.1.



Communication configuration path: "controller - communication settings".



Select "Ethernet - direct connection" in the "communication setting" interface, and then click "OK" to close the interface.

Note: Ethernet connection requires that the IP address of the connected device (PC) is automatically obtained or in the PLC IP address network segment. Therefore, before connecting, confirm whether the IP address setting of the PC meets the requirements.

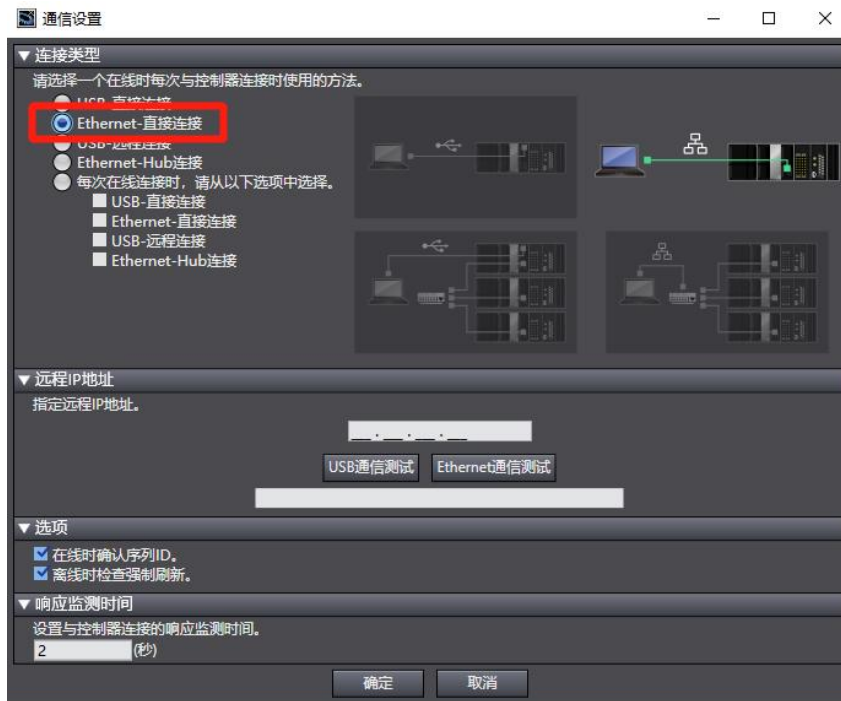

7) Compile program and prepare connection

Find "compile controller" in the toolbar to compile the project. If there is any error, check the cause of the error.



After the compilation is passed, find "online" in the toolbar and click it. If the pop-up window "failed to connect to the controller" appears, check whether the communication configuration is correct. After successful online, the upper computer switches to online status.



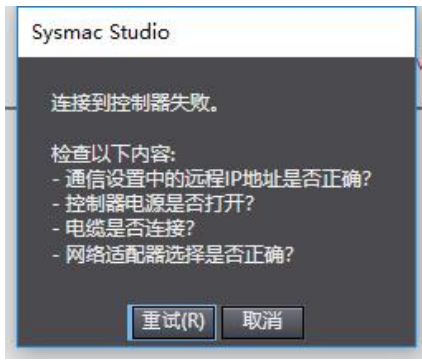

Select "synchronize" in the toolbar, and the pop-up window compares the local project with the project in the controller. The local project and the project in the controller display "out of sync". Click "transfer to controller" to download the local project and overwrite the original project of the controller.

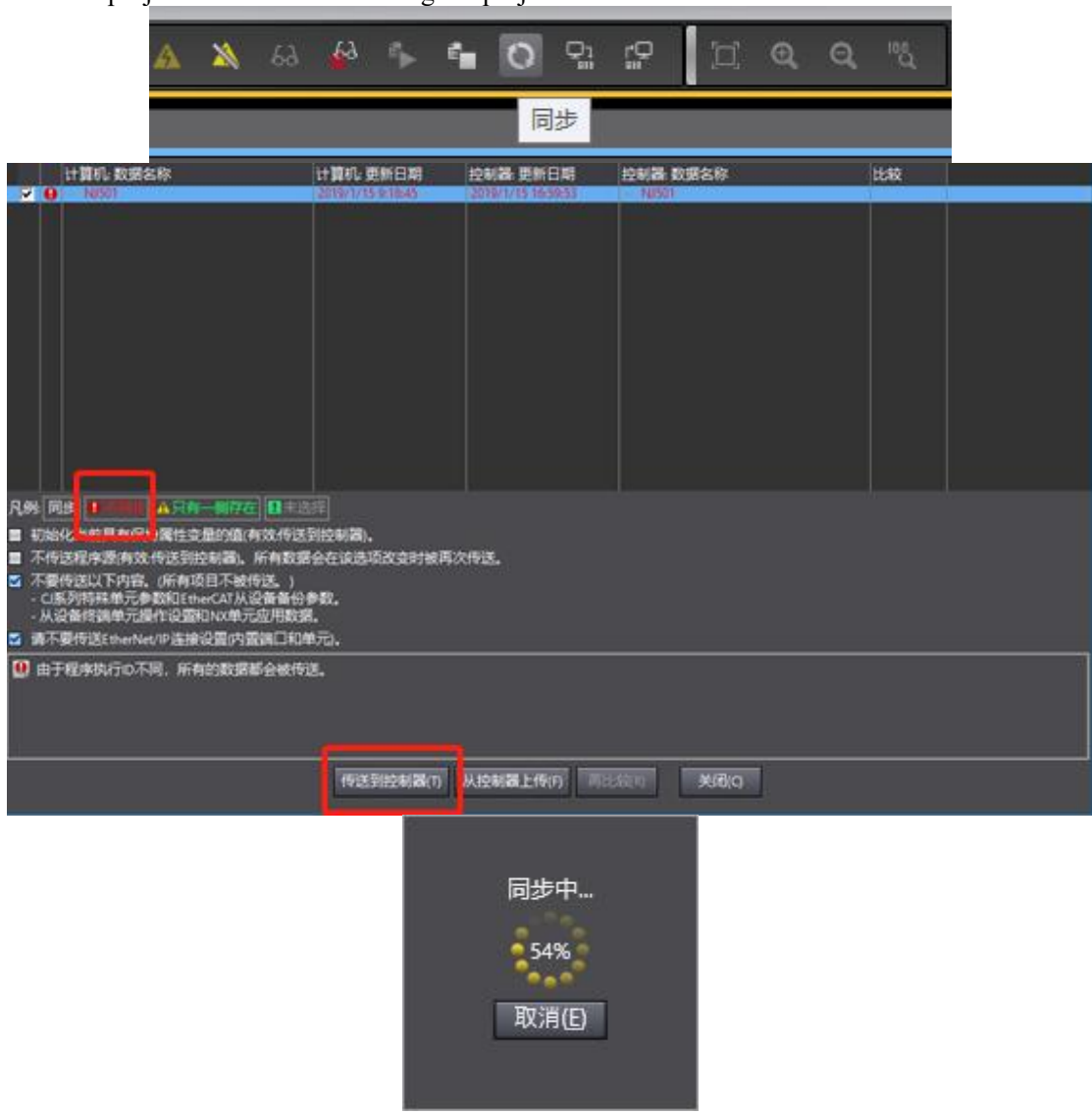

After synchronization, click "recompare" to view the synchronization items of each local project and the controller project. When the subsequent modified project is synchronized again, the different items from the controller project will be marked in detail.

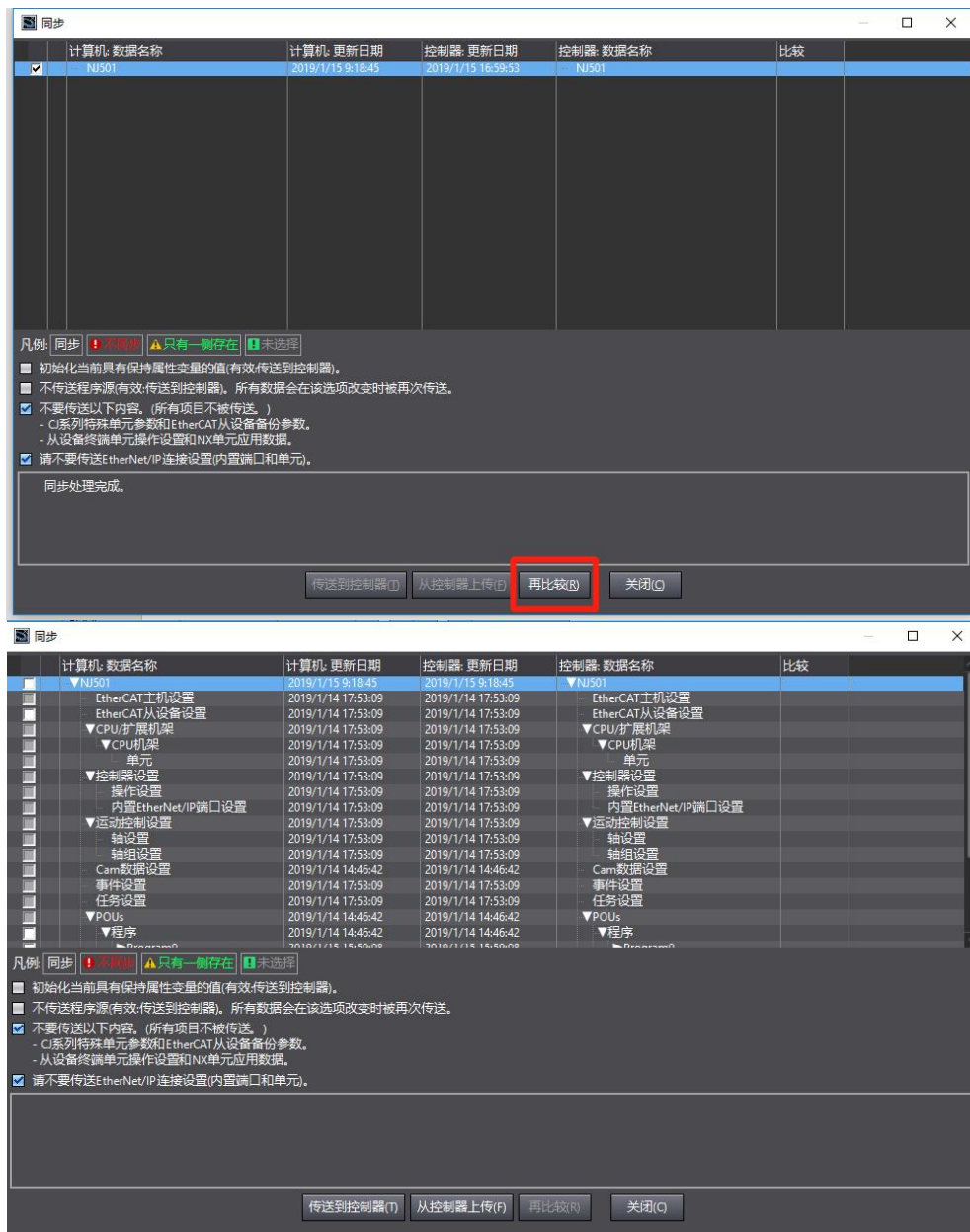

8) Online control

On the "section0" interface, right-click the variable "X0", select "Edit variable value", switch BOOL to the state "True", the function block "MC_Power" takes effect, and the servo enable is turned on. Change the state of the variable "X1" to "True" in the same way to realize the round-trip movement of the program.

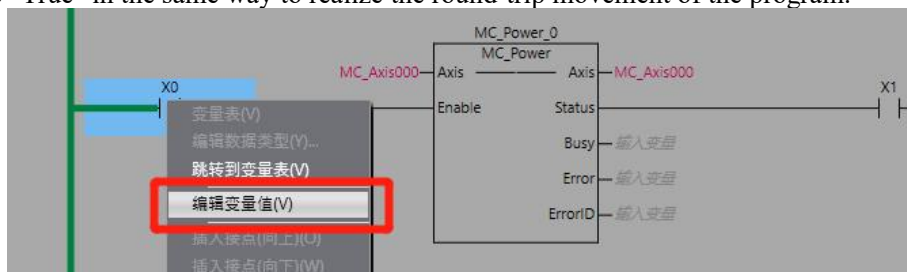

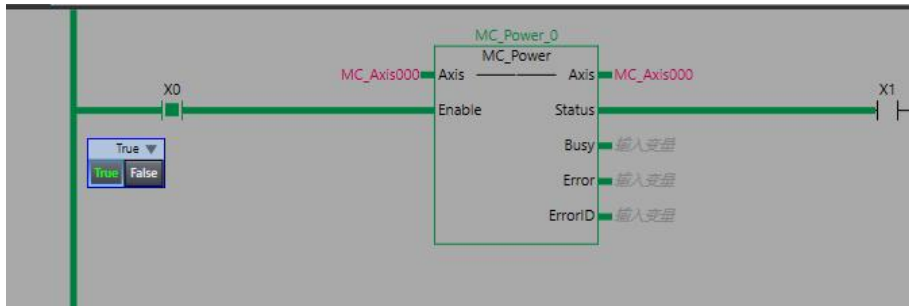

PDO object data can be monitored by "IO mapping".



位置	端口	说明	R/W	数据类型	值	变量
节点1	EtherCAT网络配置					
	XINJE-DS5-C CoE Drive					
	1st RxPDO Mapping_Controlword_604		W	UINT	15	
	1st RxPDO Mapping_Target position_6		W	DINT	121480610	
	1st RxPDO Mapping_Target Velocity_6		W	DINT	6553599	
	1st RxPDO Mapping_Target torque_60		W	INT	124	
	1st RxPDO Mapping_Modes of operat		W	SINT	8	
	1st TxPDO Mapping_Statusword_6041		R	UINT	4663	
	1st TxPDO Mapping_Position actual va		R	DINT	121302071	
	1st TxPDO Mapping_Velocity actual va		R	DINT	6556499	
	1st TxPDO Mapping_Torque actual val		R	INT	124	
	1st TxPDO Mapping_Modes of operati		R	SINT	8	
	CPU/扩展机架					
CPU机架	CPU机架0					

Appendix

Appendix 1. Driver parameters

Appendix 1.1 PX-XX

Modification and effective:

“○” means modifying when servo OFF and take effect at once.

“√” means modifying anytime and take effect at once.

“●” means modifying when servo OFF and take effect when power on again.

“△” means modifying anytime and take effect when the motor doesn't rotate.

For parameters set in hexadecimal system, the prefix "n." is added to the setting value to indicate that the current setting value is hexadecimal number.

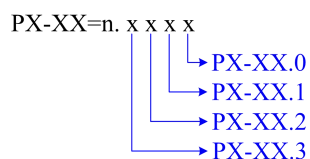

(1) P0-XX

Parameter	Function	Unit	Default value	Range	Effective	Suitable mode
P0-00	Driver type 0:General type 1:EtherCAT type	-	1	0~1	○	All
P0-01	P0-00=0:General type 1-Internal Torque Mode 3-Internal speed Model 5-Internal Location Mode P0-00=1:EtherCat type 1-Profile position control mode(PP) 3-Profile speed control mode(PV) 4-Profile torque control mode(TQ) 6-Homing mode(HM) 8-Cyclic synchronous position control mode(CSP) 9-Cyclic synchronous velocity control mode(CSV) 10-Cyclic synchronous torque control mode(CST)	-	0	1~10	○	All
P0-02	Control mode 2 (ditto) When the/C-SEL signal is valid, the servo system will switch to the mode selected by P0-02 for operation	-	0	1~10	○	All
P0-03	Enabling mode 0:not enabled 1:IO /SON enable 2:Software enable(Panel/Modbus) Write 1 to panel F1-05; Modbus: Write 1 to 0x2105 register. Write 0 disable 3:Bus Enable	-	3	0~3	○	All
P0-04	Rigidity grade	-	20P1:0 20P2/20P4/	0~63	△	All

Parameter	Function	Unit	Default value	Range	Effective	Suitable mode
			20P7:15 ≥21P5:10			
P0-05	Definition of rotation direction 0- positive mode 1- negative mode	-	0	0~1	●	All
P0-07	First inertia ratio	1%	500	0~50000	√	All
P0-11	Low bit of pulses per cycle ×1	-	0	0~9999	○	5
P0-12	High bit of pulses per cycle × 10000	-	0	0~65535	○	5
P0-13	Electronic Gear Numerator	-	1	1~65535	○(before 3770) √(3770 and later)	5
P0-14	Denominator of Electronic Gear	-	1	1~65535	○	5
P0-23	Pulse offset limit	0.01 turn	2000	0~65535	√	5
P0-24	Type selection of discharge resistance (version 3640 and before) 0: built in 1: external Power protection mode of discharge resistance (version 3700 and later) 0 - cumulative discharge time 1 - average power mode 1 2-average power mode 2	-	0	0~1	○	All
P0-25	Power Value of Discharge Resistance	W	Set as model	0~65535	○	All
P0-26	Discharge resistance value	Ω		1~500	○	All
P0-27	Servo shutdown the enable stop mode 0-Inertial Operation Stop 2-Deceleration stop	-	0	0, 2	○	All
P0-28	Servo Overrun Stop Mode (P0-28.0) 0-Deceleration stop 1 1-Inertial Stop 2-Deceleration stop 2 3-Alarm Stop Overtravel alarm shield switch (P0-28.1) 0-Not shield the alarm 1-Shield the alarm	-	0	0~3	○	All
P0-29	Servo alarm cause stop mode 0-Inertial Stop 2-Deceleration stop	-	0	0, 2	○	All
P0-30	Stop timeout time	1ms	20000	0~65535	○	All
P0-31	Deceleration stop time	1ms	25	0~5000	○	All
P0-33	Set the motor code	-		0~65535	●	All
P0-53	Read motor parameter alarm shield bit not shield alarm shield alarm 1- Shield the alarm of not read valid motor parameter	-	0	0/1	●	All
P0-55	Open loop rotation speed (Supported in 3770 and later	-	0	-6000~6000	○	All

Parameter	Function	Unit	Default value	Range	Effective	Suitable mode
	versions)					
P0-56	Number of encoder communication attempts (Supported in 3770 and later versions)	-	10	1~65535	○	All
P0-68.0~ P0-68.1 xx□□	Number of consecutive error alarms in the update sequence of coded data (supported by 3770 and later versions)	-	0x05	0x01~0xFF	●	All
P0-68.2~ P0-68.3 □□xx	E-241 Alarm filtering times (Supported in 3770 and later versions)	-	0	0~0xFF	●	All
P0-69	Fan switch (P0-69.0) 0- Turn on the fan when the temperature greater than 45°C and turn off the fan when less than 42°C (hysteresis 3°C) 1 - Turn on the fan after enabling, turn off the fan when not enabling Large motor thermocouple break alarm shield switch (P0-69.1) 0-not shield thermocouple disconnection alarm 1-shield thermocouple disconnection alarm	-	1	0/1	√	All
P0-74	Blocking alarm time	1ms	0	0-65535	√	All
P0-75	Blocking alarm speed	1rpm	50	5~9999	√	All
P0-79	Battery undervoltage alarm switch of absolute encoder (firmware version 20160304 and later) 0 - Used as absolute encoder 1 - Used as incremental encoder 2 - Used as absolute value encoder, ignoring multi turn overflow alarm	-	1	0~2	●	All
P0-80	Motor thermal power protection mode 0- Current protection 1- Average thermal power protection 2 - Analog thermal power protection	-	2	0~2	●	All
P0-92~ P0-93	32-bit electronic gear ratio numerator. take effect when P0-11~P0-14 is 0. P0-92*1 + P0-93 *10000	-	1	1~9999	○	5
			1	1~65535		
P0-94~ P0-95	32-bit electronic gear ratio denominator. P0-11~P0-14 is 0. P0-94*1 + P0-95 *10000	-	1	1~9999	○	5
			1	1~65535		

(2) P1-XX

Parameter	Function	Unit	Default value	Range	Effective	Suitable mode
P1-00	First speed loop gain	0.1Hz	20P1:400 Others:200	10~20000	√	All
P1-01	Integral Time Constant of the First	0.01ms	20P1:1650 Others:3300	15~51200	√	All

Parameter	Function	Unit	Default value	Range	Effective	Suitable mode
	Speed Loop					
P1-02	First position loop gain	0.1/s	20P1:400 Others:200	10~20000	√	All
P1-10	Speed feedforward gain	1%	0	0~300	√	5 6 7
P1-11	Speed feedforward filter time	0.01ms	50	0~10000	√	5 6 7
P1-14	Gain switching mode setting (3770 version and later)	-	0	0~0x00A2	√	All
P1-15	Gain switching waiting time (3770 version and later)	-	5	0~1000	√	All
P1-16	Gain switching level threshold (3770 version and later)	-	50	0~20000	√	All
P1-17	Gain switching level hysteresis (3770 version and later)	-	30	0~20000	√	All
P1-18	Position loop gain switching time (3770 version and later)	-	3	0~1000	√	All
P1-22	Speed Instruction Filter Selection 0-first order low pass filter 1-Smooth Average Filter	-	0	0~1	○	3 4 7
P1-23	Speed instruction filter time	0.1ms	0	0~65535	○	3 4 7
P1-24	Position command acceleration and deceleration filtering time	0.1ms	0	0~65535	△	5 6
P1-25	Position instruction smooth filter time	0.1ms	0	0~65535	△	5 6
P1-74	Encoder zero position deviation detection cycle ((3770 version and later)	-	1000	0~65535	√	All
P1-75.0~1	Encoder zero deviation detection threshold (3770 version and later)	-	0A	0~500	√	All
P1-75.2~3	Electric angle deviation detection filtering frequency (Supported in versions 3770 and higher)	-	06	0~500	√	1 2 3 4 5 6 7

(3) P2-XX

Parameter	Function	Unit	Default value	Range	Effective	Suitable mode
P2-00.0	Disturbance observer switch 0- OFF 1- ON	-	0	0~1	○	All
P2-01.0	Adaptive mode switch 0- OFF 1- ON	-	0	0~1	●	All
P2-01.1	Adaptive level 0-High response 1-Low noise	-	Set as model	0~1	●	All
P2-02.0	Auto-tuning mode 1-Soft 2-Fast positioning 3-Fast positioning, control the overshoot	-	3	1~3	√	All
P2-02.2	Load type (valid only during	-	2	1~3	√	All

Parameter	Function	Unit	Default value	Range	Effective	Suitable mode
	auto-tuning) 1-Synchronous belt 2-Screw rod 3-Rigid Connection					
P2-03.3	Adaptive load type 0-Small Inertia Mode 1-Large Inertia Mode	-	0	0~1	●	All
P2-05	Adaptive mode speed loop gain (standard)	0.1Hz	20P1/20P2/ 20P4/20P7:400 >=21P5:200	1~65535	○	All
P2-07	Adaptive mode inertia ratio (standard)	%	0	0~10000	○	All
P2-08	Gain of adaptive mode speed observer (standard)	Hz	20P1/20P2/ 20P4/20P7:60 >=21P5:40	10~1000	○	All
P2-12	Maximum Inertia Ratio of Adaptive Mode (Standard)	-	30	1~10000	○	All
P2-15	Inertia identification and internal instruction self-tuning maximum travel	0.01r	100	1~3000	√	All
P2-17	Inertia identification and internal instruction self-tuning maximum speed	-	0	0~65535	√	All
P2-18	Initial inertia ratio of inertia identification	%	500	1~20000	√	All
P2-19	Adaptive mode bandwidth	%	20P1:100 20P2/20P4:70 >=20P7:50	1~100	○	All
P2-35	Torque command filtering time constant 1	0.01ms	100	0~65535	√	All
P2-36	Torque command filtering time constant 2	0.01ms	100	0~65535	√	All
P2-41	Disturbance torque compensation coefficient (Non adaptive mode is valid)	%	85	0~100	√	All
P2-47.0	Model Loop Switch 0-OFF 1-ON	-	1	0~f	√	All
P2-49	Model loop gain	0.1Hz	500	10~20000	√	3 4 5 6 7
P2-60.0	Active Vibration Suppression Switch 0-OFF 1-ON	-	0	0~1	√	3 4 5 6 7
P2-60.1	Active Suppression Auto-tuning Switch 0-Active Vibration Suppression is not Configured in auto-tuning 1- Configure the Active Vibration Suppression when auto-tuning	-	1	0~1	√	3 4 5 6 7
P2-61	Active Vibration Suppression frequency	0.1Hz	10000	10~20000	√	All
P2-62	Active Vibration Suppression gain	%	100	1~1000	√	All
P2-63	Active Vibration Suppression damping	%	100	0~300	√	All

Parameter	Function	Unit	Default value	Range	Effective	Suitable mode
P2-64	Filtering time of active vibration suppression 1	-	0	-10000~10000	√	All
P2-65	Filtering time of active vibration suppression 2	-	0	-10000~10000	√	All
P2-69.0	Notch filter 1 switch	-	0	0~1	√	All
P2-69.1	Notch filter 2 switch	-	0	0~1	√	All
P2-69.3	Notch filter 3 switch	-	0	0~1	√	All
P2-70.0	Notch filter 4 switch	-	0	0~1	√	All
P2-70.1	Notch filter 5 switch	-	0	0~1	√	All
P2-71	First notch frequency	Hz	5000	50~5000	√	All
P2-72	First notch attenuation	0.1dB	70	50~1000	√	All
P2-73	First notch band width	Hz	0	0~1000	√	All
P2-74	Second notch frequency	Hz	5000	50~5000	√	All
P2-75	Second notch attenuation	0.1dB	70	50~1000	√	All
P2-76	Second notch band width	Hz	0	0~1000	√	All
P2-77	Third notch frequency	Hz	5000	50~5000	√	All
P2-78	Third notch attenuation	0.1dB	70	50~1000	√	All
P2-79	Third notch band width	Hz	0	0~1000	√	All
P2-80	Fourth notch frequency	Hz	5000	50~5000	√	All
P2-81	Fourth notch attenuation	0.1dB	70	50~1000	√	All
P2-82	Fourth notch band width	Hz	0	0~1000	√	All
P2-83	Fifth notch frequency	Hz	5000	50~5000	√	All
P2-84	Fifth notch attenuation	0.1dB	70	50~1000	√	All
P2-85	Fifth notch band width	Hz	0	0~1000	√	All

(4)P3-XX Speed control parameters

Parameter	Function	Unit	Default value	Range	Effective	Suitable mode
P3-05	Preset speed 1	rpm	0	-9999~9999	√	3
P3-06	Preset speed 2	rpm	0	-9999~9999	√	3
P3-07	Preset speed 3	rpm	0	-9999~9999	√	3
P3-09	Acceleration time	ms	0	0~65535	○	3
P3-10	Deceleration time	ms	0	0~65535	○	3
P3-12	Zero-speed clamping mode	-	0	0~3	○	3
P3-13	Zero-speed clamping speed	rpm	10	0~300	○	3
P3-14	Forward Maximum Speed Instruction Limit	rpm	4000	0~10000	○	All
P3-15	Reverse Maximum Speed Instruction Limit	rpm	4000	0~10000	○	All
P3-16	Internal Forward Speed Limitation in Torque Control	rpm	2000	5~10000	√	1
P3-17	Internal Reverse Speed Limitation in Torque Control	rpm	2000	5~10000	√	1
P3-18	Jogging speed	rpm	100	0~1000	○	All

Parameter	Function	Unit	Default value	Range	Effective	Suitable mode
P3-19	Forward warning speed	rpm	3000	0~10000	○	All
P3-20	Reverse warning speed	rpm	3000	0~10000	○	All
P3-21	Forward alarming speed	rpm	4000	0~10000	○	All
P3-22	Reverse alarming speed	rpm	4000	0~10000	○	All
P3-28	Internal forward torque limit	%	300	0~1000	√	All
P3-29	Internal reverse torque limit	%	300	0~1000	√	All
P3-30	External forward torque limit	%	300	0~1000	√	All
P3-31	External reverse torque limit	%	300	0~1000	√	All
P3-32	Brake torque	1%	300	0~1000	√	All
P3-33	Preset torque	%	0	-1000~1000	√	1
P3-45	Torque mode switching delay	ms	40	0~9999	√	1

(5)P4-XX Internal position parameters

Parameter	Function	Unit	Default value	Range	Effective	Suitable mode
P4-00.0	Z phase signal numbers The Z phase signal numbers after leaving the limit switch (note: stop when N+1 Z phase signal reached)	-	2	0~f	○	5 6
P4-00.1	Search the origin function 0-OFF 1-ON	-	0	0~1	○	5 6
P4-00.2	Return to zero overrun prohibition 0-not prohibit 1-prohibit	-	0	0~1	○	5 6
P4-01	Speed of hitting the proximity switch	rpm	600	0~65535	○	5 6
P4-02	Speed of leaving proximity switch	rpm	100	0~65535	○	5 6
P4-03.0	Internal Location Given Mode Sets Location Mode 0-Relative positioning 1-Absolute positioning	-	0	0~1	○	5
P4-03.1	Internal position setting mode Set step change mode 0 - Step change when signal is ON, recyclable 1 - Step change on the rising edge of the signal, single step execution 2 - The rising edge of the signal is started, and all the signals are executed in sequence without circulation 3 - Communication setting section number 4 -/CHSTP bilateral edge trigger 5- Terminal/PREFA (P5-57),/PREFB (P5-58),/PREFC (P5-59) select segment number, and 1~3 segments can be selected	-	0	0~5	○	5
P4-03.2	Internal position mode sets waiting mode	-	0	0~1	○	5

Parameter	Function	Unit	Default value	Range	Effective	Suitable mode
	0-wait positioning completion 1-not wait positioning completion					
P4-04	Valid segment number	-	0	0~35	○	5
P4-10~P4-11	First segment pulse	1pul	0	-327689999~ 327679999	√	5
P4-12	First segment speed	0.1rpm	0	0~65535	√	5
P4-13	First segment acceleration time	1ms	0	0~65535	√	5
P4-14	First segment deceleration time	1ms	0	0~65535	√	5
P4-16	Adjusting time	1ms	0	0~65535	√	5
P4-10+(n-1)*7 ~ P4-16+(n-1)*7	Segment 1 to 35 pulse parameters (n is segment number)	-	-	-	√	5

Note:

1) Set pulse number=pulse number (high bit) × 10000+pulses (low order);

2) 35 sections in total; The parameters of sections 1 to 12 can be set through the panel, and the parameters of sections 13 to 35 need to be written through communication (RS232 and RS485).

(6)P5-XX Signal parameter setting

Parameter	Function	Unit	Default value	Range	Effective	Suitable mode
P5-00	Positioning completion width/COIN	Command unit	11	1~65535	√	5 6
P5-01	Location Completion Detection Mode	-	0	0~3	√	5 6
P5-02	Location completion retention time	ms	0	0~65535	√	5 6
P5-03	Rotation Detection Speed	rpm	50	0~10000	√	All
P5-04	Same speed detection speed	rpm	50	0~10000	√	All
P5-05	Reached detection speed	rpm	1000	0~10000	√	All
P5-06	Positioning near output width	Command unit	50	0~65535	√	5 6
P5-07	Servo OFF delay time	ms	500	-500~65535	○	All
P5-08	Brake instruction output speed	rpm	30	20~10000	○	All
P5-09	Brake instruction waiting time	ms	500	0~65535	○	All
P5-10	User-defined output 1 trigger condition	-	0	0~ffff	√	All
P5-11	Set a value that compares with the trigger condition of custom output 1	Related to trigger condition	0	-9999~9999	√	All
P5-12	Select custom output 1 mode	-	0	0~3	√	All
P5-13	Setting custom output 1 hysteresis	Related to trigger condition	0	0~65535	√	All
P5-14	Custom Output 2 Trigger Condition	-	0	0~ffff	√	All
P5-15	Set a value that compares with the trigger condition of custom output 2	Related to trigger condition	0	-9999~9999	√	All
P5-16	Select custom output 2 mode	-	0	0~3	√	All
P5-17	Setting custom output 2 hysteresis	Related to trigger condition	0	0~65535	√	All
P5-18	IO filter time multiple	-	1	0~10000	√	All
P5-19	Z-phase output holding time	ms	2	1~65535	√	All

Parameter	Function	Unit	Default value	Range	Effective	Suitable mode
P5-20.0~1	/S-ON: servo signal 00: Set the signal to be invalid all the time. 01: Input positive signal from SI1 terminal. 02: Input positive signal from SI2 terminal. 03: Input positive signal from SI3 terminal. 04: Input positive signal from SI4 terminal. 10: Set the signal to always be "valid". 11: Inverse signal is input from SI1 terminal. 12: Inverse signal is input from SI2 terminal. 13: Inverse signal is input from SI3 terminal. 14: Inverse signal is input from SI4 terminal.	-	0	0~ff	√	All
P5-20.2	SI terminal filtering time	ms	0	0~f	√	All
P5-21.0~1	/P-CON proportion action instruction	-	00	0~ff	√	All
P5-21.2	SI terminal filtering time	ms	0	0~f	√	All
P5-22.0~1	In non EtherCAT mode: /P-OT: Forward drive prohibited EtherCAT mode: Control mode 6 (return to zero mode), POT inhibit signal	-	01	0~ff	√	All
P5-22.2	SI terminal filtering time	ms	0	0~f	√	All
P5-23.0~1	In non EtherCAT mode: /N-OT: Reverse drive prohibited EtherCAT mode: Control mode 6 (return to zero mode), NOT inhibit signal	-	02	0~ff	√	All
P5-23.2	SI terminal filtering time	ms	0	0~f	√	All
P5-24.0~1	/ALM-RST: alarm clear	-	0	0~ff	√	All
P5-24.2	SI terminal filtering time	ms	0	0~f	√	All
P5-25.0~1	/P-CL: External Torque Limitation at Forward Rotation Side	-	00	0~ff	√	All
P5-25.2	SI terminal filtering time	ms	0	0~f	√	All
P5-26.0~1	/N-CL: External Torque Limitation at Reverse Rotation Side	-	00	0~ff	√	All
P5-26.2	SI terminal filtering time	ms	0	0~f	√	All
P5-27.0~1	In non EtherCAT mode: /SPD-D: Internal Speed Direction Selection In EtherCAT mode: Control mode 6 (return to zero mode), Home Origin signal	-	03	0~ff	√	1 2 3 4 7
P5-27.2	SI terminal filtering time	ms	0	0~f	√	1 2 3 4 7
P5-28.0~1	/SPD-A: Internal Setting Speed Selection	-	00	0~ff	√	3 5

Parameter	Function	Unit	Default value	Range	Effective	Suitable mode
P5-28.2	SI terminal filtering time	ms	0	0~f	√	3 5
P5-29.0~1	/SPD-B: Internal Setting Speed Selection	-	00	0~ff	√	3 5
P5-29.2	SI terminal filtering time	ms	0	0~f	√	3 5
P5-30.0~1	/C-SEL: control mode selection	-	00	0~ff	√	All
P5-30.2	SI terminal filtering time	ms	0	0~f	√	All
P5-31.0~1	/ZCLAMP: zero position clamping	-	00	0~ff	√	3 4 7
P5-31.2	SI terminal filtering time	ms	0	0~f	√	3 4 7
P5-32.0~1	/INHIBIT: Instruction pulse prohibition	-	00	0~ff	√	5 6 7
P5-32.2	SI terminal filtering time	ms	0	0~f	√	5 6 7
P5-33.0~1	/G-SEL: gain switching	-	00	0~ff	√	All
P5-33.2	Filtering time of SI terminal	ms	0	0~f	√	All
P5-34.0~1	/CLR: pulse offset clear	-	00	0~ff	√	5 6
P5-34.2	SI terminal filtering time	ms	0	0~f	√	5 6
P5-35.0~1	/CHGSTP: internal position mode change step signal	-	00	0~ff	√	5
P5-35.2	SI terminal filtering time	ms	0	0~f	√	5
P5-36.0~1	/I-SEL: Inertia ratio switching	-	00	0~ff	√	All
P5-36.2	SI terminal filtering time	ms	0	0~f	√	All
P5-37	/COIN_HD: Location Completion Maintenance 00: No output to terminal 01: Output positive signal from SO1 terminal 02: Output positive signal from SO2 terminal 03: Output positive signal from SO3 terminal 11: Output reverse signal from SO1 terminal 12: Output reverse signal from SO2 terminal. 13: Output reverse Signal from SO3 terminal	-	0000	0~ffff	√	5 6
P5-38	/COIN: positioning completion	-	0001	0~ffff	√	5 6
P5-39	/V-CMP: same speed detection	-	0000	0~ffff	√	3 4 7
P5-40	/TGON: rotation detection	-	0000	0~ffff	√	All
P5-41	/S-RDY: ready	-	0000	0~ffff	√	All
P5-42	/CLT: torque limit	-	0000	0~ffff	√	All
P5-43	/VLT: speed limit detection	-	0000	0~ffff	√	1 2
P5-44	/BK: brake locking	-	0000	0~ffff	○	All
P5-45	/WARN: warning	-	0000	0~ffff	√	All
P5-46	/NEAR: near	-	0000	0~ffff	√	5 6
P5-47	/ALM: alarm	-	0002	0~ffff	√	All
P5-48	/Z: encoder Z phase signal output	-	0000	0~ffff	√	All
P5-50	/MRUN: internal position mode motion starting signal	-	0000	0~ffff	√	5
P5-51	/V-RDY: speed reached	-	0000	0~ffff	√	3 4 7
P5-52	/USER1: User-defined output 1	-	0000	0~ffff	√	All
P5-53	/USER2: User-defined output 2	-	0000	0~ffff	√	All
P5-57	/PREFA: Internal position selection	-	0	※1	√	5

Parameter	Function	Unit	Default value	Range	Effective	Suitable mode
	signal A					
P5-58	/PREFB: Internal position selection signal B	—	0	※1	√	5
P5-59	/PREFC: Internal position selection signal C	—	0	※1	√	5
P5-61.0~1	/TRAJ-START: Motion start trigger signal	-	00	0~ff	√	5
P5-62	Probe function 1	—	0	0005	○	EtherCAT mode
P5-63	Probe function 2	—	0	0006	○	EtherCAT mode
P5-68	Terminal emergency alarm function	-	0000	0~65535	√	All
P5-70	/SRDY: Output Conditions Selection 0: This terminal is turned on after initialization of the driver is completed 1: This terminal will not turn on until enabled.	-	0	0~1	√	All
P5-71	Function Selection of Directional Terminal of Pulse Speed Mode	-	0	0~1	√	7
P5-72	Remote input of SI input 1 (3791 and later versions)	-	0	0~ff	√	EtherCAT mode
P5-73	Remote input of SI input 2 (3791 and later versions)	-	0	0~ff	√	EtherCAT mode
P5-74	Remote input of SI input 3 (3791 and later versions)	-	0	0~ff	√	EtherCAT mode
P5-76	Remote input of SO output 1 (3791 and later versions)	-	0	0~ff	√	EtherCAT mode
P5-77	Remote input of SO output 2 (3791 and later versions)	-	0	0~ff	√	EtherCAT mode
P5-78	Remote input of SO output 3 (3791 and later versions)	-	0	0~ff	√	EtherCAT mode

(7)P6-XX Signal parameter settings(Some parameters are reserved)

Parameter	Function	Unit	Default value	Range	Effective	Suitable mode
P6-05	Adaptive Mode Speed Loop Gain (Large Inertia)	0.1Hz	200	1~65535	○	1 2 3 4 5 6 7
P6-07	Adaptive mode inertia ratio (Large inertia)	%	50	0~10000	○	1 2 3 4 5 6 7
P6-08	Gain of adaptive mode speed observer (large inertia)	Hz	40	10~1000	○	1 2 3 4 5 6 7
P6-12	Maximum Inertia Ratio of Adaptive Mode (Large Inertia)	-	50	1~10000	○	1 2 3 4 5 6 7

(8)P7-XX Communication parameter setting(485 communication is not supported temporarily)

Parameter	Function	Unit	Default value	Range	Effective	Suitable mode
P7-00	Slave station no.	-	0 (3791 and higher version) 1 (before 3791 versions)	0~100	○	EtherCAT mode
P7-10	RS232 station no.	-	1	0~100	○	1 3 5 6 7

Parameter	Function	Unit	Default value	Range	Effective	Suitable mode
P7-11.0~1	RS232 baud rate 00:300 01:600 02:1200 03:2400 04:4800 05:9600 06:19200 07:38400 08:57600 09:115200 0A:192000 0B:256000 0C:288000 0D:384000 0E:512000 0F:576000 10:768000 11:1M 12:2M 13:3M 14:4M 15:5M 16:6M	Baud rate	06	0~16	○	1 3 5 6 7
P7-11.2	RS232 stop bit 0:2 bit 2:1 bit	Stop bit	2	0~2	○	1 3 5 6 7
P7-11.3	RS232 stop bit 0: no parity 1: odd parity 2: even parity	Parity bit	2	0~2	○	1 3 5 6 7
P7-20	Ethercat homing find Z phase numbers (3791 and higher versions)	-	1	-9999~9999	○	EtherCAT mode
P7-21	Filter time after homing (3791 and higher version)	Scan period	400	1~65535	○	EtherCAT mode

(9)P8-XX

Parameter	Function	Unit	Default value	Range	Effective	Suitable mode
P8-25	Panel display selection(supported by 3770 and later versions)	-	0	0~2	▲	1 3 5 6 7

(10) P9-XX (supported by version 3791 and higher)

Parameter	Function	Unit	Default value	Range	Effective	Suitable mode
P9-16	Touch stop homing speed threshold	rpm	2	0~1000	○	EtherCAT mode
P9-17	Touch stop homing torque threshold	%	100	0~300	○	EtherCAT mode
P9-18	Touch stop homing time threshold	ms	500	10~1500	○	EtherCAT mode
P9-19	Quantitative pulse number low bit	-	0	-9999~9999	○	EtherCAT mode
P9-20	Quantitative pulse number	-	0	-9999~9999	○	EtherCAT mode

Parameter	Function	Unit	Default value	Range	Effective	Suitable mode
	high bit					

Table 1 Input Signal Distribution

Input terminal parameters	Servo model	Range
P5-20~P5-36 P5-57~P5-59 P5-72~P5-74	DS5C1 series	n.0000~n.0003 n.0010~n.0013

Table 2 Input Signal Distribution

Output terminal parameters	Servo model	Range
P5-37~P5-53 P5-76~P5-78	DS5C1 series	n.0000~n.0003 n.0010~n.0013

Appendix 1.2 FX-XX

Code	Contents
F0-00	Clear the alarm
F0-01	Restore to out of factory settings
F0-02	clear the position offset
F1-00	Jog run
F1-01	Test run
F1-02	Current sampling zero calibration
F1-05	Panel enable
F1-06	Absolute encoder clearing cycles

Appendix 1.3 U0-XX

U0-XX:

Parameter	Content	Unit
U0-00	Current speed of servo motor	Rpm
U0-01	Input speed instruction	Rpm
U0-02	Torque instruction	% rated
U0-03	Mechanical angle	1°
U0-04	Electric angle	1°
U0-05	Bus voltage	V
U0-06	IPM temperature	0.1°C
U0-07	Torque feedback	% rated
U0-08	Pulse offset	(0000~9999)*1
U0-09		(0000~65535)*10000
U0-10	Encoder feedback	(0000~9999)*1
U0-11	Encoder feedback	(0000~65535)*10000
U0-12	Input instruction pulse numbers	(0000~9999)*1
U0-13		(0000~65535)*10000
U0-14	Position feedback	(0000~9999)*1
U0-15		(0000~65535)*10000
U0-16	Encoder accumulated position	(0000~9999)*1
U0-17		(0000~65535)*10000
U0-18	Torque current	0.01A
U0-21	Input signal status 1	-
U0-22	Input signal status 2	-
U0-23	Output signal status 1	-

Parameter	Content		Unit
U0-24	Output signal status 2		-
U0-25	Input pulse frequency	(0000~9999)*1	Hz
U0-26		(0000~9999)*10000	
U0-41	Instantaneous output power		1W
U0-42	Average output power		1W
U0-43	Instantaneous thermal power		1W
U0-44	Average thermal power		1W
U0-49	Position feedforward		1 Command unit
U0-50	Speed feedforward		rpm
U0-51	Torque feedforward		% rated
U0-52	Instantaneous Bus Capacitor Power		1W
U0-53	Average Bus Capacitor Power		1W
U0-54	Encoder error count		-
U0-55	Instantaneous regenerative braking discharge power		1W
U0-56	Average regenerative braking discharge power		1W
U0-57	Absolute encoder present position feedback low 32-bit		Encoder Position
U0-58			
U0-59	Absolute encoder present position feedback high 32-bit		Encoder Position
U0-60			
U0-80	Internal position mode error segment number		-
U0-81	Internal position mode current segment number		-
U0-88	Read and write motor parameter result flag		-
U0-89	Real-time speed feedback (displaying range -99.99~99.99rpm)		0.01rpm
U0-90	Maximum deviation of starting position under static state		-
U0-91	Multi-turn absolute motor circles		-
U0-94	Encoder feedback position after calibration	(0000~65536)*1	Encoder pulses
U0-95		(0000~65536)*2 ¹⁶	
U0-96		(0000~65536)*2 ³²	
U0-97		(0000~65536)	
U0-98	High power motor temperature (3770 version and later)		0.1°C

U1-XX:

Parameter	Contents	Unit
U1-00	Current alarm code	-
U1-01	Current warning code	-
U1-02	U phase current when alarming	0.01A
U1-03	V phase current when alarming	0.01A
U1-04	Bus voltage when alarming	V
U1-05	IGBT temperature when alarming	0.1°C
U1-06	Torque current when alarming	0.01A
U1-07	Excitation current when alarming	A
U1-08	Position offset when alarming	Instruction pulse
U1-09	Speed value when alarm occurs	rpm
U1-10	Seconds(low 16-bit) when alarming, cumulated seconds from the first time power-on	s
U1-11	Seconds(high 16-bit) when alarming, cumulated seconds from the first time power-on	s
U1-12	The number of errors in this operation is calculated after this power on	-
U1-13	The number of warnings for this operation is calculated after this power on	-
U1-14	Historical alarm amounts	-
U1-15	Historical warning amounts	-
U1-16	Recent 1st alarm code	-
U1-17	Recent 2nd alarm code	-
U1-18	Recent 3rd alarm code	-

Parameter	Contents	Unit
U1-19	Recent 4th alarm code	-
U1-20	Recent 5th alarm code	-
U1-21	Recent 6th alarm code	-
U1-22	Recent 7th alarm code	-
U1-23	Recent 8th alarm code	-
U1-24	Recent 9th alarm code	-
U1-25	Recent 10th alarm code	-

U2-XX:

Parameter	Contents	Unit
U2-00	Power on times	-
U2-01	Series	-
U2-02	Model (low 16-bit)	-
U2-03	Model (high 16-bit)	-
U2-04	out of factory date: year	-
U2-05	out of factory date: month	-
U2-06	out of factory date: day	-
U2-07	Firmware version	-
U2-08	Hardware version	-
U2-09	Total running time (from the first time power on)	hour
U2-10	Total running time (from the first time power on)	minute
U2-11	Total running time (from the first time power on)	second
U2-12	This time running time (from this time power on)	hour
U2-13	This time running time (from this time power on)	minute
U2-14	This time running time (from this time power on)	second
U2-15	Average output power (from the first time enabled, average power in the process of enabling)	1W
U2-16	Average thermal power (from the first time enabled, average power in the process of enabling)	1W
U2-17	Average bus capacitor filter power (from the first time power on, average power in the process of power on)	1W
U2-18	Accumulated motor turns	(0000~9999)*1
U2-19		(0000~9999)*10000
U2-20	Device serial no.: low 16-bit	-
U2-21	Device serial no.: high 16-bit	-
U2-22	Firmware generation date: year	-
U2-23	Firmware generation date: month/day	-
U2-24	Firmware generation date: hour/minute	-

U3-XX:

Parameter	Contents	Unit
U3-00	Motor code automatically read by drive (including thermal power parameters)	-
U3-01	Motor version	-
U3-02	Encoder version	-
U3-70	Automatically read the motor code of the encoder in the motor parameters (only related to the motor code)	-

U4-XX:

Parameter	Contents	Unit
U4-10	Resonance frequency detected by fast FFT	Hz
U4-16	Thermal power protection continuous overload operation accumulation value (supported by 3770 version and later)	-
U4-17	Thermal power protection instantaneous overload operation accumulation value (supported by 3770 version and later)	-

U4-18	SI terminal effective status (supported in 3790 version and later)	-
U4-19	SO terminal effective status(supported in 3790 version and later)	-

U5-XX:

Parameter	Contents	Unit
U5-00	Sync0 period time	us
U5-05	Port0 RX Error Count (Stop counting until 255)	-
U5-07	Port1 RX Error Count (Stop counting until 255)	-
U5-12	Port0 Link loss count (stop counting until 255)	-
U5-13	Port1 Link loss count (stop counting until 255)	-
U5-19	Synchronous offset time	us

Appendix 2. Object dictionary

All objects are configured in the object dictionary of each group through 4 digits 16-bit index configuration address.

The object dictionary of CoE (CANopen over EtherCAT) specified by CiA402 and the object dictionary of DS5C1 series are as follows:

Object dictionary specified by CiA402		DS5C1 series object dictionary	
Index	Content	Index	Content
0000h~0FFFh	Data type area	0000h~0FFFh	Data type area
1000h~1FFFh	COE communication area	1000h~1FFFh	COE communication area
2000h~5FFFh	Factory custom area	2000h~2FFFh	Servo parameter area
		3000h~3FFFh	
		4000h~4FFFh	
		5000h~5FFFh	
6000h~9FFFh	Profile area	6000h~6FFFh	Driver Profile area
		7000h~9FFFh	Reserved
A000h~FFFFh	Reserved	A000h~FFFFh	Reserved

Appendix 2.1 COE communication area (0x1000-0x1FFF)

Index	Sub-index	Name	Unit	Range	Data type	Access	PDO
1000h	00h	Device type	-	0-429496795	U32	RO	NO
1001h	00h	Error register	-	0-65535	U16	RO	NO
1008h	00h	Device	-	-	-	RO	NO
1009h	00h	Hardware version	-	-	-	RO	NO
100Ah	00h	Software version	-	-	-	RO	NO
1018h	00h	Identity	-	-	-	RO	-
	01h	Vendor ID	-	0-255	U8	RO	NO
	02h	Product code	-	0-429496795	U32	RO	NO
	03h	Revision	-	0-429496795	U32	RO	NO
	04h	Serial number	-	0-429496795	U32	RO	NO
1600h	-	Receive PDO mapping 1	-	-	-	-	-
	00h	Number of entries	-	0-24	U8	RW	NO
	01h	1st receive PDO mapped	-	0-4294967295	U32	RW	NO
	02h	2nd receive PDO mapped	-	0-4294967295	U32	RW	NO
	03h	3rd receive PDO mapped	-	0-4294967295	U32	RW	NO
	-	0-4294967295	U32	RW	NO
	18h	24th receive PDO mapped	-	0-4294967295	U32	RW	NO
1601h	-	Receive PDO mapping 2	-	-	-	-	-
	00h	Number of entries	-	0-24	U8	RW	NO
	01h	1st receive PDO mapped	-	0-4294967295	U32	RW	NO
	02h	2nd receive PDO mapped	-	0-4294967295	U32	RW	NO
	03h	3rd receive PDO mapped	-	0-4294967295	U32	RW	NO
	-	0-4294967295	U32	RW	NO
	18h	24th receive PDO mapped	-	0-4294967295	U32	RW	NO
1602h	-	Receive PDO mapping 3	-	-	-	-	-
	00h	Number of entries	-	0-24	U8	RW	NO
	01h	1st receive PDO mapped	-	0-4294967295	U32	RW	NO
	02h	2nd receive PDO mapped	-	0-4294967295	U32	RW	NO
	03h	3rd receive PDO mapped	-	0-4294967295	U32	RW	NO
	-	0-4294967295	U32	RW	NO

Index	Sub-index	Name	Unit	Range	Data type	Access	PDO
	18h	24th receive PDO mapped	-	0-4294967295	U32	RW	NO
1603h	-	Receive PDO mapping 4	-	-	-	-	-
	00h	Number of entries	-	0-24	U8	RW	NO
	01h	1st receive PDO mapped	-	0-4294967295	U32	RW	NO
	02h	2nd receive PDO mapped	-	0-4294967295	U32	RW	NO
	03h	3rd receive PDO mapped	-	0-4294967295	U32	RW	NO
	-	0-4294967295	U32	RW	NO
	18h	24th receive PDO mapped	-	0-4294967295	U32	RW	NO
1A00h	-	Transmit PDO mapping 1	-	-	-	-	-
	00h	Number of entries	-	0-24	U8	RW	NO
	01h	1st transmit PDO mapped	-	0-4294967295	U32	RW	NO
	02h	2nd transmit PDO mapped	-	0-4294967295	U32	RW	NO
	03h	3rd transmit PDO mapped	-	0-4294967295	U32	RW	NO
	-	0-4294967295	U32	RW	NO
	18h	24th transmit PDO mapped	-	0-4294967295	U32	RW	NO
1A01h	-	Transmit PDO mapping 2	-	-	-	-	-
	00h	Number of entries	-	0-24	U8	RW	NO
	01h	1st transmit PDO mapped	-	0-4294967295	U32	RW	NO
	02h	2nd transmit PDO mapped	-	0-4294967295	U32	RW	NO
	03h	3rd transmit PDO mapped	-	0-4294967295	U32	RW	NO
	-	0-4294967295	U32	RW	NO
	18h	24th transmit PDO mapped	-	0-4294967295	U32	RW	NO
1A02h	-	Transmit PDO mapping 3	-	-	-	-	-
	00h	Number of entries	-	0-24	U8	RW	NO
	01h	1st transmit PDO mapped	-	0-4294967295	U32	RW	NO
	02h	2nd transmit PDO mapped	-	0-4294967295	U32	RW	NO
	03h	3rd transmit PDO mapped	-	0-4294967295	U32	RW	NO
	-	0-4294967295	U32	RW	NO
	18h	24th transmit PDO mapped	-	0-4294967295	U32	RW	NO
1A03h	-	Transmit PDO mapping 4	-	-	-	-	-
	00h	Number of entries	-	0-24	U8	RW	NO
	01h	1st transmit PDO mapped	-	0-4294967295	U32	RW	NO
	02h	2nd transmit PDO mapped	-	0-4294967295	U32	RW	NO
	03h	3rd transmit PDO mapped	-	0-4294967295	U32	RW	NO
	-	0-4294967295	U32	RW	NO
	18h	24th transmit PDO mapped	-	0-4294967295	U32	RW	NO
1C00h	-	Sync mangager communication type	-	-	-	-	-
	00h	Number of used sync manager channels	-	0-255	U8	RO	NO
	01h	Communication type sync manager 0	-	0-4	U8	RO	NO
	02h	Communication type sync manager 1	-	0-4	U8	RO	NO
	03h	Communication type sync manager 2	-	0-4	U8	RO	NO
	04h	Communication type sync manager 3	-	0-4	U8	RO	NO
	1C12h	00h	Number of assigned PDOs	-	0-4	U8	RW
01h		Assigned RxPDO 1	-	1600h-1603h	U16	RW	NO
02h		Assigned RxPDO 2	-	1600h-1603h	U16	RW	NO
03h		Assigned RxPDO 3	-	1600h-1603h	U16	RW	NO
04h		Assigned RxPDO 4	-	1600h-1603h	U16	RW	NO
1C13h	00h	Number of assigned PDOs	-	0-4	U8	RW	NO

Index	Sub-index	Name	Unit	Range	Data type	Access	PDO
	01h	Assigned TxPDO 1	-	1A00h-1A03h	U16	RW	NO
	02h	Assigned TxPDO 2	-	1A00h-1A03h	U16	RW	NO
	03h	Assigned TxPDO 3	-	1A00h-1A03h	U16	RW	NO
	04h	Assigned TxPDO 4	-	1A00h-1A03h	U16	RW	NO
1C32h	-	Sync manager 2 synchronization	-	-	-	-	-
	00h	Number of sub-objects			U8	RO	NO
	01h	Sync mode	-	0-65535	U16	RW	NO
	02h	Cycle time	ns	0-4294967295	U32	RW	NO
	03h	Shift time	ns	0-4294967295	U32	RW	NO
	04h	Sync modes supported	-	0-65535	U16	RO	NO
	05h	Minimum cycle time	ns	0-4294967295	U32	RO	NO
	06h	Calc and copy time	ns	0-4294967295	U32	RO	NO
	08h	Command(not support)	ns	0-65535	U16	RO	NO
	09h	Delay time(not support)	ns	0-4294967295	U32	RO	NO
	0Ah	Sync0 cycle time	-	0-4294967295	U32	RO	NO
	0Bh	Cycle time too small(not support)	-	0-65535	U16	RO	NO
	0Ch	SM-event missed(not support)	-	0-65535	U16	RO	NO
	0Dh	Shift time too short(not support)	-	0-65535	U16	RO	NO
	0Eh	RxPDO toggle failed(not support)	-	0-65535	U16	RW	NO
20h	Sync error	-	0-1	BOOL	RO	NO	
1C33h	-	Sync manager 3 synchronization	-	0-20h	U8	RO	NO
	00h	Number of sub-objects	-	0-65535	U16	RW	NO
	01h	Sync mode	ns	0-4294967295	U32	RW	NO
	02h	Cycle time	ns	0-4294967295	U32	RW	NO
	03h	Shift time	-	0-65535	U16	RO	NO
	04h	Sync modes supported	ns	0-4294967295	U32	RO	NO
	05h	Minimum cycle time	ns	0-4294967295	U32	RO	NO
	06h	Calc and copy time	ns	0-65535	U16	RO	NO
	08h	Command(not support)	ns	0-4294967295	U32	RO	NO
	09h	Delay time(not support)	-	0-4294967295	U32	RO	NO
	0Ah	Sync0 cycle time	-	0-65535	U16	RO	NO
	0Bh	Cycle time too small(not support)	-	0-65535	U16	RO	NO
	0Ch	SM-event missed(not support)	-	0-65535	U16	RO	NO
	0Dh	Shift time too short(not support)	-	0-65535	U16	RW	NO
	0Eh	RxPDO toggle failed(not support)	-	0-65535	U16	RO	NO
20h	Sync error	-	0-1	BOOL	RO	NO	

Appendix 2.2 Servo parameter area

Index	Sub-index	Name
2000h	00h	P0-00
2001h	00h	P0-01
2002h	00h	P0-02
2003h	00h	P0-03
...
205Fh	00h	P0-95
2100h	00h	P1-00
2101h	00h	P1-01
2102h	00h	P1-02

Index	Sub-index	Name
2500h	00h	P5-00
2501h	00h	P5-01
2502h	00h	P5-02
2503h	00h	P5-03
...
2547h	00h	P5-71
2700h	00h	P7-00
2701h	00h	P7-01
2702h	00h	P7-02

2103h	00h	P1-03
...
214Ah	00h	P1-74
2200h	00h	P2-00
2201h	00h	P2-01
2202h	00h	P2-02
2203h	00h	P2-03
...
2263h	00h	P2-99
2300h	00h	P3-00
2301h	00h	P3-01
2302h	00h	P3-02
2303h	00h	P3-03
...
232Eh	00h	P3-46

2703h	00h	P7-03
...
2715h	00h	P7-21
2800h	00h	P8-00
2801h	00h	P8-01
2802h	00h	P8-02
2803h	00h	P8-03
...
281Ah	00h	P8-26

Appendix 2.3 Driver Profile area(0x6000~0x6FFF)

Error code (603Fh)

Index	Sub index	Name	Range	Data type	Accessibility	PDO	Suitable mode
603Fh	00h	Error code	0~65535	U16	ro	TxPDO	ALL
		Display the main number of alarms that are occurring in the servo drive. (for 3791 and later versions, universal alarm displays complete error codes)					

Control word (6040h)

Index	Sub index	Name	Range	Data type	Accessibility	PDO	Suitable mode
6040h	00h	Controlword	0~65535	U16	rw	RxPDO	ALL
		Set control commands for servo drivers such as PDS state transitions.					

Bit information of 6040h:

Bit	Name	Note
0	switch on	Servo ready
1	enable voltage	Connect the main circuit power supply
2	quick stop	Quick stop
3	enable operation	Servo running
4	operation mode specific	Control mode dependency bit
5	operation mode specific	Control mode dependency bit
6	operation mode specific	Control mode dependency bit
7	fault reset	fault reset
8	halt	halt
		When bit8=1, execute motor deceleration pause through 605Dh (Halt selection code). After pausing, the enable must be turned off to restart the action

9	operation mode specific	Control mode dependency bit	In other modes: this bit is undefined
10~15	Reserved	Reserved	-

6040h bit0~3, bit7 information:

Command	6040h bit					PDS conversion
	bit7	bit3	bit2	bit1	bit0	
Shutdown	0	-	1	1	0	2, 6, 8
Switch on	0	0	1	1	1	3
Switch on + Enable operation	0	1	1	1	1	3+4
Enable operation	0	1	1	1	1	4, 16
Disable voltage	0	-	-	0	-	7, 9, 10, 12
Quick stop	0	-	0	1	-	7, 10, 11
Disable operation	0	0	1	1	1	5
Fault reset	0→1	-	-	-	-	13

Status word (6041h)

The commands for PDS state migration and control of the slave station are set through 6040h (control word).

Index	Sub index	Name	Range	Data type	Accessibility	PDO	Suitable mode
6041h	00h	Statusword	0~65535	U16	ro	TxPDO	ALL

6041h bit information:

Bit	Name		Note
0	ready to switch on	Main circuit power off status	-
1	switched on	Servo ready status	-
2	operation enabled	Servo running	-
3	fault	Fault	-
4	voltage enabled	Main circuit power on status	1: Indicates that the power supply voltage is printed onto the PDS
5	quick stop	quick stop	0: Indicates that PDS receives a quick stop request. The bit logic of quick stop is valid at 0. Please note to execute other bit logic and reverse actions
6	switch on disabled	Servo cannot run	-
7	warning	warning	1: Indicates that a warning is occurring. When warned, the PDS status remains unchanged and the motor continues to operate.
8	reserved	reserved	-
9	remote	Remote control	0: Indicates that 6040h is in an unprocessed state. 1: Indicates that 6040h is in a manageable state. The ESM state changes to 1 when transitioning above PreOP.
10	operation mode specific	Control mode dependency bit	PP, PV, TQ, HM: target reached In other modes: this bit is undefined
11	internal limit active	The internal position of the software exceeds the limit	The main reason for internal limitations is that the bit11 of 6041h becomes 1 when it occurs
12	operation mode	Control mode	PP: set-point acknowledge

Bit	Name		Note
	specific	dependency bit	PV: speed HM: homing attained CSP, CSV, CST: drive follows command value TQ: this bit no definition
13	operation specific	Control mode dependency bit	PP: following error HM: homing error CSP: following error In other modes: this bit is undefined
14~15	reserved	reserved	Value fixed to 0

6041h bit6~5, bit3~0 information:

6041h		PDS status	
xxxx xxxx x0xx 0000 b	Not ready to switch on	Incomplete initialization status	
xxxx xxxx x1xx 0000 b	Switch on disabled	Initialization completion status	
xxxx xxxx x01x 0001 b	Ready to switch on	Initialization completion status	
xxxx xxxx x01x 0011 b	Switched on	Servo enable off/servo ready	
xxxx xxxx x01x 0111 b	Operation enabled	Servo enable on	
xxxx xxxx x00x 0111 b	Quick stop active	Stop immediately	
xxxx xxxx x0xx 1111 b	Fault reaction active	Abnormal (alarm) judgment	
xxxx xxxx x0xx 1000 b	Fault	Abnormal (alarm) state	

Quick stop mode (605Ah)

Index	Sub index	Name	Unit	Range	Data type	Accessibility	PDO	Suitable mode
605Ah	00h	Quick stop option code	-	0~7	I16	rw	NO	ALL

605Ah information:

Control mode	Value	Effective deceleration	PDS status after stop
pp, csp, csv, pv mode	0	Free stop on servo side	Switch on disabled
	1	6084h	
	2	6085h	
	3	60C6h	Quick stop active
	5	6084h	
	6	6085h	
	7	60C6h	
Hm mode	0	Free stop on servo side	Switch on disabled
	1	609Ah	
	2	6085h	
	3	60C6h	Quick stop active
	5	609Ah	
	6	6085h	
	7	60C6h	
cst, tq mode	0	Free stop on servo side	Switch on disabled
	1, 2	6087h	
	3	Torque set to 0	
	5, 6	6087h	Quick stop active
	7	Torque set to 0	

Example of deceleration stop action based on Quick stop command:

A: If 6040h: bit2 (Controlword: quick stop) changes from 1 to 0, start decelerating stop.

The PDS status during deceleration changes to Quick stop active.

B: The motor stops when the actual speed is detected to be below 10r/min.

The PDS status after stopping is Switch on disabled or changed to Quick stop active.

stop mode selection (605Bh)

Index	Sub index	Name	Unit	Range	Data type	Accessibility	PDO	Suitable mode
605Bh	00h	Shutdown option code	-	0~1	I8	rw	RxPDO	ALL

605Bh information:

(1) When PDS command 「Shutdown」 is receiving

Control mode	Value	Effective deceleration	PDS status after stop
pp, csp, csv, pv mode	0	Free stop on servo side	Ready to switch on
	1	6084h	
Hm mode	0	Free stop on servo side	
	1	609Ah	
cst, tq mode	0	Free stop on servo side	
	1	6087h	

(2) When PDS command 「Disable voltage」 is receiving

Control mode	value	Effective deceleration	PDS status after stop
pp, csp, csv, pv mode	0	Free stop on servo side	Switch on disabled
	1	6084h	
Hm mode	0	Free stop on servo side	
	1	609Ah	
cst, tq mode	0	Free stop on servo side	
	1	6087h	

An example of slowing down and stop based on the Shutdown command:

A: If you receive the PDS command "Shutdown" to start deceleration and stop.

The PDS status during deceleration remains Operation enabled.

B: The motor stops when the actual speed is detected to be below 10r/min.

The PDS status after stopping is Ready to switch on.

Servo OFF shutdown mode selection (605Ch)

Index	Sub index	Name	Unit	Range	Data type	Accessibility	PDO	Suitable mode
605Ch	00h	Servo OFF shutdown mode	-	0~1	I8	rw	RxPDO	ALL

605Ch value information:

Current control mode	Value	Effective deceleration	PDS status after shutdown
pp, csp, csv, pv mode	0	Servo side free stop	Switched on
	1	6084h	
Hm mode	0	Servo side free stop	
	1	609Ah	
cst, tq mode	0	Servo side free stop	
	1	6087h	

An example of slowing down and stop based on the Disable operation command.

A: If you receive the PDS command "Disable operation", start deceleration and stop.

The PDS status during deceleration remains Operation enabled.

B: Motor stops when the actual speed is below 10 r/min.

The PDS status bit after stop is Switched on.

Pause shutdown mode selection (605Dh)

Index	Sub index	Name	Unit	Range	Data type	Accessibility	PDO	Suitable mode
605Dh	00h	Pause shutdown mode selection	-	1~3	I16	rw	NO	ALL

605Dh value information:

Current control mode	Value	Effective deceleration	PDS status after shutdown
----------------------	-------	------------------------	---------------------------

pp, csp, csv, pv mode	1	6084h	Operation enabled
	2	6085h	
	3	6072h, 60C6h	
Hm mode	1	609Ah	
	2	6085h	
	3	6072h, 60C6h	
cst, tq mode	1, 2	6087h	
	3	Torque set to 0	

Examples of deceleration and stop based on the Halt function

A: If 6040h: bit8 (Controlword: halt) changes from 0 to 1, start decelerating and stop. The PDS status during deceleration remains Operation enabled.

B: the motor stops when the actual speed is below 10 r/min. After stopping, the PDS status remains in Operation enabled.

Alarm shutdown mode selection (605Eh)

Index	Sub index	Name	Unit	Range	Data type	Accessibility	PDO	Suitable mode
605Eh	00h	Fault reaction option code	-	0~2	I16	rw	NO	ALL

605Eh value information:

(1) When EtherCAT communication association abnormal alarm occurs (E-800~E-899):

Current control mode	Value	Effective deceleration	PDS status after shutdown
pp, csp, csv, pv mode	0	Servo side free stop	Fault
	1	6084h	
	2	6085h	
Hm mode	0	Servo side free stop	
	1	609Ah	
	2	6085h	
cst, tq mode	0	Servo side free stop	
	1, 2	6087h	

(2) When EtherCAT communication is not associated with abnormal alarms (not E-800~E-899):

Current control mode	Value	Effective deceleration	PDS status after shutdown
pp, csp, csv, pv hm, cst, tq	0, 2, 3	Servo side free stop	Fault

Examples of deceleration and stop based on alarms.

A: If an alarm occurs, start decelerating and stop. The PDS status during deceleration is Fault reaction active.

B: the motor stops when the actual speed is below 10 r/min. The PDS status after stopping is Fault.

Control mode setting (6060h)

The control mode is set through 6060h.

Index	Sub index	Name	Range	Data type	Accessibility	PDO	Suitable mode
6060h	00h	Mode of operation	-128~127	I8	rw	RxPDO	All

6060h bit information:

bit	Definition	abbr	correspond
-128~-1	-	-	-
0	No mode changed/No mode assigned	-	-
1	Profile position mode	pp	YES
3	Profile velocity mode	pv	YES
4	Torque profile mode	tq	YES
6	Homing mode	hm	YES
8	Cyclic synchronous position mode	csp	YES
9	Cyclic synchronous velocity mode	csv	YES
10	Cyclic synchronous torque mode	cst	YES
11~127	-	-	-

Since 6060h is the default = (no mode change/no mode assigned), be sure to set the control mode value used after power input. When the set value for 6060h is 0 and the set value for 6061h is 0, an E-881(Control Mode

Set Exception Protection) occurs if the PDS state migrates to Operation enabled.

After the initial state is converted from 0 to the supported control mode (pp, pv, tq, hm, csp, csv, cst), set 6060h to 0 again, the previous control mode will be maintained as "No mode changed", and the switch of control mode cannot be performed.

Control mode display (6061h)

The confirmation of the internal control mode of the servo drive is performed according to 6061h. After setting 6060h, please confirm whether it is feasible to set this object action by detection.

Index	Sub index	Name	Range	Data type	Accessibility	PDO	Suitable mode
6061h	00h	Mode of operation display	-128~127	I8	ro	TxPDO	All

6061h bit information:

bit	Definition	abbr	correspond
-128~ -1	-	-	-
0	No mode changed/No mode assigned	-	-
1	Profile position mode	pp	YES
3	Profile velocity mode	pv	YES
4	Torque profile mode	tq	YES
6	Homing mode	hm	YES
8	Cyclic synchronous position mode	csp	YES
9	Cyclic synchronous velocity mode	csv	YES
10	Cyclic synchronous torque mode	cst	YES
11~127	-	-	-

Position command (6062h)

Index	Sub index	Name	Unit	Range	Data type	Accessibility	PDO	Suitable mode
6062h	00h	Position command	Command unit	-2147483648~2147483647	I32	ro	TxPDO	PP CSP HM

Internal actual position feedback (6063h)

Index	Sub index	Name	Unit	Range	Data type	Accessibility	PDO	Suitable mode
6063h	00h	Internal actual position feedback	Command unit	-2147483648~2147483647	I32	ro	TxPDO	ALL

Position feedback (6064h)

Index	Sub index	Name	Unit	Range	Data type	Accessibility	PDO	Suitable mode
6064h	00h	Position feedback	Command unit	-2147483648~2147483647	I32	ro	TxPDO	ALL

Position deviation too large threshold (6065h)

Index	Sub index	Name	Unit	Range	Data type	Accessibility	PDO	Suitable mode
6065h	00h	Position deviation too large threshold	Command unit	0~4294967295	U32	rw	RxPDO	PP CSP
		When the difference between the position instruction 6062h and the position feedback 6064h exceeds 6065h and the time reaches 6066h, the bit 13 of 6041h will be set to 1.						

Excessive position deviation timeout (6066h)

Index	Sub index	Name	Unit	Range	Data type	Accessibility	PDO	Suitable mode
6066h	00h	Excessive position	1ms	0~65535	U16	rw	RxPDO	PP

		deviation timeout						CSP
When the difference between the position instruction 6062h and the position feedback 6064h exceeds 6065h and the time reaches 6066h, the bit 13 of 6041h will be set to 1.								

Position reach threshold (6067h)

Index	Sub index	Name	Unit	Range	Data type	Access ibility	PDO	Suitable mode
6067h	00h	Position reach threshold	Command unit	0~4294967295	U32	rw	RxPDO	PP
		When the difference between the position instruction 6062h and the position feedback 6064h is within the set range of 6067h, and the time reaches 6068h, the bit 10 of 6041h will be set to 1.						

Position command reached threshold time (6068h)

Index	Sub index	Name	Unit	Range	Data type	Access ibility	PDO	Suitable mode
6068h	00h	Position command reached threshold time	1ms	0~65535	U16	rw	RxPDO	PP
		When the difference between the position instruction 6062h and the position feedback 6064h is within the set range of 6067h, and the time reaches 6068h, the bit 10 of 6041h will be set to 1.						

Speed command (606Bh)

Index	Sub index	Name	Unit	Range	Data type	Access ibility	PDO	Suitable mode
606Bh	00h	Speed command	Command unit /s	-2147483648~2147483647	I32	RO	TxPDO	PV CSV

Speed feedback (606Ch)

Index	Sub index	Name	Unit	Range	Data type	Accessibility	PDO	Suitable mode
606Ch	00h	Speed feedback	Command unit /s	-2147483648~2147483647	I32	ro	TxPDO	ALL

Speed reached threshold (606Dh)

Index	Sub index	Name	Unit	Range	Data type	Access ibility	PDO	Suitable mode
606Dh	00h	Speed reached threshold	command unit	0~4294967295	U32	rw	RxPDO	PV
		When the difference between the speed command 606Bh and the speed feedback 606Ch is within the set range of 606Dh, and the time reaches 606Eh, the bit 10 of 6041h will be set to 1.						

Speed reached threshold time (606Eh)

Index	Sub index	Name	Unit	Range	Data type	Access ibility	PDO	Suitable mode
606Eh	00h	Speed reached threshold time	1ms	0~65535	U16	rw	RxPDO	PV
		When the difference between the speed command 606Bh and the speed feedback 606Ch is within the set range of 606Dh, and the time reaches 606Eh, the bit 10 of 6041h will be set to 1.						

Speed threshold (606Fh)

Index	Sub index	Name	Unit	Range	Data type	Accessibility	PDO	Suitable mode
-------	-----------	------	------	-------	-----------	---------------	-----	---------------

606Fh	00h	Velocity threshold	Command unit	0~4294967295	U32	rw	RxPDO	PV
When the value of speed feedback 606Ch exceeds the set value of 606Fh and the time reaches 6070h, the threshold value of bit 12 for 6041h is set to 0. If the speed is below the set value of this parameter, the bit12 of 6041h becomes 1.								

Speed threshold time (6070h)

Index	Sub index	Name	Unit	Range	Data type	Accessibility	PDO	Suitable mode
6070h	00h	Velocity threshold time	1ms	0~65535	U16	rw	RxPDO	PV
When 606Ch exceeds the set value of 606Fh, set the time for bit12 of 6041h to become 0.								

Target torque (6071h)

Index	Sub index	Name	Unit	Range	Data type	Accessibility	PDO	Suitable mode
6071h	00h	Target torque	0.1%	-32768~32767	I16	rw	RxPDO	TQ

Max torque (6072h)

Index	Sub index	Name	Unit	Range	Data type	Accessibility	PDO	Suitable mode
6072h	00h	Max torque	0.1%	0~65535	U16	rw	RxPDO	ALL

Max current (6073h)

Index	Sub index	Name	Unit	Range	Data type	Accessibility	PDO	Suitable mode
6073h	00h	Max current	0.1%	0~65535	U16	ro	NO	ALL

Torque command (6074h)

Index	Sub index	Name	Unit	Range	Data type	Accessibility	PDO	Suitable mode
6074h	00h	Torque command	0.1%	-32768~32767	I16	ro	TxPDO	ALL

Motor rated torque (6076h)

Index	Sub index	Name	Unit	Range	Data type	Accessibility	PDO	Suitable mode
6076h	00h	Motor rated torque	Mn·m	0 ~ 4294967295	U32	RO	TxPDO	ALL

Torque feedback (6077h)

Index	Sub index	Name	Unit	Range	Data type	Accessibility	PDO	Suitable mode
6077h	00h	Torque feedback	0.1%	-32768~32767	I16	ro	TxPDO	ALL

Current feedback (6078h)

Index	Sub index	Name	Unit	Range	Data type	Accessibility	PDO	Suitable mode
6078h	00h	Current feedback	0.10%	-32768~32767	I16	RO	TxPDO	ALL

Bus voltage (6079h)

Index	Sub index	Name	Unit	Range	Data type	Accessibility	PDO	Suitable mode
6079h	00h	DC link circuit voltage	mV	0~4294967295	U32	RO	TxPDO	ALL

Target position (607Ah)

Index	Sub index	Name	Unit	Range	Data type	Accessibility	PDO	Suitable mode
607Ah	00h	Target position	Command unit	-2147483648~2147483647	I32	rw	RxPDO	PP CSP HM

Position range limit (607Bh)

Index	Sub index	Name	Unit	Range	Data type	Accessibility	PDO	Suitable mode
607Bh	01h	Min position range limit	command unit	-2147483648~2147483647	I32	rw	RxPDO	ALL
	02h	Max position range limit	command unit	-2147483648~2147483647	I32	rw	RxPDO	ALL

This parameter modification has no effect.

Home offset (607Ch)

Index	Sub index	Name	Unit	Range	Data type	Accessibility	PDO	Suitable mode
607Ch	00h	Home Offset	command unit	-2147483648~2147483647	I32	rw	RxPDO	NO

Soft limit (607Dh)

Index	Sub index	Name	Unit	Range	Data type	Accessibility	PDO	Suitable mode
607Dh	01h	Min position limit	command unit	-2147483648~2147483647	I32	rw	RxPDO	NO
	02h	Max position limit	command unit	-2147483648~2147483647	I32	rw	RxPDO	NO

Command polarity (607Eh)

Index	Sub index	Name	Unit	Range	Data type	Accessibility	PDO	Suitable mode
607Eh	00h	Command Polarity	-	0~255	U8	rw	NO	ALL

607Eh bit information

bit	Name	value	note	note
0-4	-	0	-	Reserved, please set to 0
5	Torque polarity	0	Symbol without inversion	0: No inversion of symbols
		1	Symbol has inversion	1: The symbol has inversion
6	Speed polarity	0	Symbol without inversion	0: No inversion of symbols
		1	Symbol has inversion	1: The symbol has inversion
7	Position polarity	0	Symbol without inversion	0: No inversion of symbols
		1	Symbol has inversion	1: The symbol has inversion



The position, speed, and torque polarity must be exactly the same, that is, bit7-5 must all be set to 0 or bit7-5 must all be set to 1.

Max profile speed (607Fh)

Index	Sub index	Name	Unit	Range	Data type	Accessibility	PDO	Suitable mode
607Fh	00h	Max profile velocity	command unit/s	0~4294967295	U32	rw	RxPDO	PP PV HM
Speed limit values in pp, hm, and pv mode. The maximum value is limited by 6080h through internal processing.								

Max motor speed (6080h)

Index	Sub index	Name	Unit	Range	Data type	Accessibility	PDO	Suitable mode
6080h	00h	Max motor speed	r/min	0~4294967295	U32	rw	RxPDO	PV TQ CSV CST
Set the maximum speed of the motor. When power supply input, the maximum speed read from the motor is set. The maximum value is limited by the maximum speed read from the motor based on internal processing. During tq and cst, the speed is limited by the set value of this object.								

Profile speed (6081h)

Index	Sub index	Name	Unit	Range	Data type	Accessibility	PDO	Suitable mode
6081h	00h	Profile velocity	command unit/s	0~4294967295	U32	rw	RxPDO	PP

Profile acceleration (6083h)

Index	Sub index	Name	Unit	Range	Data type	Accessibility	PDO	Suitable mode
6083h	00h	Profile acceleration	command unit/s ²	0~4294967295	U32	rw	RxPDO	PP PV
Set profile acceleration. When set to 0, internal processing is processed as 1.								

Profile deceleration (6084h)

Index	Sub index	Name	Unit	Range	Data type	Accessibility	PDO	Suitable mode
6084h	00h	Profile deceleration	command unit/s ²	0~4294967295	U32	rw	RxPDO	PP PV HM CSP CSV
Set the profile deceleration. When set to 0, internal processing is processed as 1.								

Fast stop deceleration (6085h)

Index	Sub index	Name	Unit	Range	Data type	Accessibility	PDO	Suitable mode
6085h	00h	Fast stop deceleration	command unit/s ²	0~4294967295	U32	rw	RxPDO	PP PV HM CSP CSV

Motor rated current (6075h)

Index	Sub index	Name	Unit	Range	Data type	Accessibility	PDO	Suitable mode
6075h	00h	Motor rated current	1mA	0 ~4294967295	U32	RO	TxPDO	PP PV HM CSP CSV

Position trajectory planning type (6086h)

Index	Sub index	Name	Unit	Range	Data type	Accessibility	PDO	Suitable mode
6086h	00h	Position trajectory planning type	-	-32768~32767	I16	rw	RxPDO	HM

This parameter 0: Step type; 1: Slope type.

This parameter is only applicable to HM mode. In PP and PV modes, slope types are directly used within trajectory planning.

In CSP and CSV modes, this parameter is not required and trajectory planning is completed at the main station.

Torque slope (6087h)

Index	Sub index	Name	Unit	Range	Data type	Accessibility	PDO	Suitable mode
6087h	00h	Torque slope	0.1%	0~4294967295	U32	rw	RxPDO	TQ CST
Set the parameter values to give a bias torque command. In CST mode, it is only effective in deceleration stop time.								

Torque planning type (6088h)

Index	Sub index	Name	Unit	Range	Data type	Accessibility	PDO	Suitable mode
6088h	00h	Torque planning type	-	0~65535	I16	rw	RxPDO	TQ

This parameter 0: Step type; 1: Slope type.

In TQ mode, the slope type directly used for torque planning, modifying this parameter has no effect.

Electronic gear ratio (6091h)

Index	Sub index	Name	Unit	Range	Data type	Accessibility	PDO	Suitable mode
6091h	01h	Motor revolutions	Turns (motor)	1~4294967295	U32	rw	NO	ALL
	02h	Shaft revolutions	Turns (shaft)	1~4294967295	U32	rw	NO	ALL

This object defines the content related to the motor turns and the shaft turns after the gearbox output.

Gear ratio = 6091h-01h/ 6091h-02h

Encoder division ratio (6092h)

Index	Sub index	Name	Unit	Range	Data type	Accessibility	PDO	Suitable mode
6092h	01h	Feed	command unit	1~4294967295	U32	rw	NO	ALL
		Set feed quantity						
	02h	Shaft revolutions	Turns (shaft)	1~4294967295	U32	rw	NO	ALL
		Set shaft turns						

This object represents the amount of action for each rotation of the shaft after the gearbox output.

Feed constant =6092h-01h/ 6092h-02h

Homing mode (6098h)

Index	Sub index	Name	Range	Data type	Accessibility	PDO	Suitable mode
6098h	00h	Homing method	-128~127	I8	rw	RxPDO	All

6098h value information:

value	definition
-2	Searching for reverse limits (supported in versions 3791 and higher)
-1	Searching for positive limits (supported in versions 3791 and higher)
0	Not specify the homing method
1	Reverse homing, the deceleration point is the reverse limit switch, and the origin is the motor Z signal. Before encountering the Z signal, the descending edge of the reverse limit must be encountered first
2	Forward homing, deceleration point is the forward limit switch, origin is the motor Z signal, and the falling edge of the forward limit must be encountered before encountering the Z signal
3	Positive homing, deceleration point is the origin switch, and the origin is the motor Z signal. Before encountering the Z signal, it is necessary to first encounter the falling edge on the same side of the origin switch
4	Positive homing, deceleration point is the origin switch, and the origin is the motor Z signal. Before encountering the Z signal, it is necessary to first encounter the rising edge on the same side of the origin switch
5	Reverse homing, deceleration point is the origin switch, and the origin is the motor Z signal. Before encountering the Z signal, it is necessary to first encounter the falling edge on the same side of the origin switch
6	Reverse homing, deceleration point is the origin switch, and the origin is the motor Z signal. Before encountering the Z signal, it is necessary to first encounter the rising edge on the same side of the origin switch
7	Positive homing, deceleration point is the origin switch, and the origin is the motor Z signal. Before encountering the Z signal, it is necessary to first encounter the falling edge on the same side of the origin switch
8	Positive homing, deceleration point is the origin switch, and the origin is the motor Z signal. Before encountering the Z signal, it is necessary to first encounter the rising edge on the same side of the origin switch
9	Positive homing, deceleration point is the origin switch, and the origin is the motor Z signal. Before encountering the Z signal, you must first encounter the rising edge on the other side of the origin switch
10	Positive homing, deceleration point is the origin switch, and the origin is the motor Z signal. Before encountering the Z signal, it is necessary to first encounter the falling edge on the other side of the origin switch
11	Reverse homing, deceleration point is the origin switch, and the origin is the motor Z signal. Before encountering the Z signal, it is necessary to first encounter the falling edge on the same side of the origin switch
12	Reverse homing, deceleration point is the origin switch, and the origin is the motor Z signal. Before encountering the Z signal, it is necessary to first encounter the rising edge on the same side of the origin switch
13	Reverse homing, deceleration point is the origin switch, and the origin is the motor Z signal on the other side of the origin switch. Before encountering the Z signal, the rising edge on the other side of

value	definition
	the origin switch must be encountered first
14	Reverse homing, deceleration point is the origin switch, and the origin is the Z signal of the motor on the other side of the origin switch. Before encountering the Z signal, the falling edge on the other side of the origin switch must be encountered first
15	No meaning
16	No meaning
17	Homing action is the same as 1, but the origin is at the reverse limit position
18	Homing action is the same as 2, but the origin is at the forward limit position
19	Homing action is the same as 3, but the origin is at the origin switch
20	Homing action is the same as 4, but the origin is at the origin switch
21	Homing action is the same as 5, but the origin is at the origin switch
22	Homing action is the same as 6, but the origin is at the origin switch
23	Homing action is the same as 7, but the origin is at the origin switch
24	Homing action is the same as 8, but the origin is at the origin switch
25	Homing action is the same as 9, but the origin is at the origin switch
26	Homing action is the same as 10, but the origin is at the origin switch
27	Homing action is the same as 11, but the origin is at the origin switch
28	Homing action is the same as 12, but the origin is at the origin switch
29	Homing action is the same as 13, but the origin is at the origin switch
30	Homing action is the same as 14, but the origin is at the origin switch
31	No meaning
32	No meaning
33	Reverse homing, with the origin at the Z-phase signal of the motor
34	Forward homing, with the origin at the Z-phase signal of the motor
35	Take the current position as the origin
37	Take the current position as the origin

Homing speed (6099h)

Index	Sub index	Name	Unit	Range	Data type	Accessibility	PDO	Suitable mode
6099h	01h	Speed during search for deceleration point	command unit/s	0~4294967295	U32	rw	NO	HM
	02h	Speed during search for zero	command unit/s	0~4294967295	U32	rw	NO	HM
		If the edge of the Switch signal is used as the origin detection position, please set a value as small as possible to reduce detection error.						



The speeds of 6099-01h and 6099-02h are limited by the minimum values of 6080h and 607Fh.

Homing acceleration (609Ah)

Index	Sub index	Name	Unit	Range	Data type	Accessibility	PDO	Suitable mode
609Ah	00h	Homing acceleration	command unit/s ²	0~4294967295	U32	rw	RxPDO	HM
		Set the acceleration and deceleration during HM mode. At the final stop of each homing mode (when the origin position is detected), there is no need to use the set value of this object, and the servo lock stops.						

Position feedforward (60B0h)

Index	Sub index	Name	Unit	Range	Data type	Accessibility	PDO	Suitable mode
60B0h	00h	Position feedforward	command unit	-2147483648~2147483647	I32	rw	RxPDO	ALL
		This parameter is used for the position loop control of the drive. As the servo underlying algorithm does not support feedforward control, this parameter is temporarily not used. Modifying it does not affect the effect.						

Speed feedforward (60B1h)

Index	Sub index	Name	Unit	Range	Data type	Accessibility	PDO	Suitable mode
60B1h	00h	Velocity feedforward	command unit/s	-2147483648~2147483647	I32	rw	RxPDO	ALL
		This parameter is used for the speed loop control of the drive. As the servo underlying algorithm does not support feedforward control, this parameter is temporarily not used. Modifying it does not affect the effect.						

Torque feedforward (60B2h)

Index	Sub index	Name	Unit	Range	Data type	Accessibility	PDO	Suitable mode
60B2h	00h	Torque feedforward	0.1%	-2147483648~2147483647	I32	rw	RxPDO	ALL
		This parameter is used for the current loop control of the drive. As the servo underlying algorithm does not support feedforward control, this parameter is temporarily not used. Modifying it does not affect the effect.						

Touch Probe function (60B8h)

Index	Sub index	Name	Unit	Range	Data type	Accessibility	PDO	Suitable mode
60B8h	00h	Touch probe function	-	0~65535	U16	rw	RxPDO	ALL

60B8h bit information:

bit	value	Note	
0	0	Probe 1 not enabled	Probe 1 enabled
	1	Probe 1 enabled	
1	0	Single triggering	Probe 1 trigger mode selection
	1	Continuous triggering	
2	0	External input signal	Probe 1 trigger method selection
	1	Z phase signal (not support)	
3	-	-	-
4	0	Rising edge not latched	Probe 1 rising edge selection
	1	Rising edge latched	
5	0	Falling edge not latched	Probe 1 falling edge selection
	1	Falling edge latched	
6-7	-	-	-
8	0	Probe 2 not enabled	Probe 2 enabled
	1	Probe 2 enabled	
9	0	Single triggering	Probe 2 trigger mode selection
	1	Continuous triggering	
10	0	External input signal	Probe 2 trigger method selection
	1	Z phase signal (not support)	
11	-	-	-
12	0	Rising edge not latched	Probe 2 rising edge selection
	1	Rising edge latched	
13	0	Falling edge not latched	Probe 2 falling edge selection

	1	Falling edge latched	
14-15	-	-	-



- At present, Z-phase triggering mode is not supported, only external signals are supported as triggering sources;
- Do not set the rising and falling edges simultaneously under the same probe.

Touch probe status (60B9h)

Index	Sub index	Name	Unit	Range	Data type	Accessibility	PDO	Suitable mode
60B9h	00h	Touch probe status	-	0~65535	U16	ro	TxPDO	ALL

60B9h bit information:

bit	value	Note	
0	0	Probe 1 not executed	Probe 1 execution status
	1	Probe 1 is executing	
1	0	Probe 1 rising edge latch not completed	Probe 1 rising edge latch state
	1	Probe 1 rising edge latch completed	
2	0	Probe 1 falling edge latch not completed	Probe 1 falling edge latch state
	1	Probe 1 falling edge latch completed	
3-7	-	-	-
8	0	Probe 2 not executed	Probe 2 execution status
	1	Probe 2 is executing	
9	0	Probe 2 rising edge latch not completed	Probe 2 rising edge latch state
	1	Probe 2 rising edge latch completed	
10	0	Probe 2 falling edge latch not completed	Probe 2 falling edge latch state
	1	Probe 2 falling edge latch completed	
11-15	-	-	-

probe 1 rising edge latch position value (60BAh)

Index	Sub index	Name	Unit	Range	Data type	Accessibility	PDO	Suitable mode
60BAh	00h	probe 1 rising edge latch position value	Command unit	-2147483648~2147483647	I32	ro	TxPDO	ALL

probe 1 falling edge latch position value (60BBh)

Index	Sub index	Name	Unit	Range	Data type	Accessibility	PDO	Suitable mode
60BBh	00h	probe 1 falling edge latch position value	Command unit	-2147483648~2147483647	I32	ro	TxPDO	ALL

probe 2 rising edge latch position value (60BCh)

Index	Sub index	Name	Unit	Range	Data type	Accessibility	PDO	Suitable mode
60BCh	00h	probe 2 rising edge latch position value	Command unit	-2147483648~2147483647	I32	ro	TxPDO	ALL

probe 2 falling edge latch position value (60BDh)

Index	Sub index	Name	Unit	Range	Data type	Accessibility	PDO	Suitable mode
60BDh	00h	probe 2 falling edge latch position value	Command unit	-2147483648~2147483647	I32	ro	TxPDO	ALL

Max acceleration (60C5h)

Index	Sub index	Name	Unit	Range	Data type	Accessibility	PDO	Suitable mode
60C5h	00h	Max acceleration	command unit/s ²	0~4294967295	U32	rw	RxPDO	PP PV HM
Set the maximum acceleration. When set to 0, internal processing is processed as 1.								

Min deceleration (60C6h)

Index	Sub index	Name	Unit	Range	Data type	Accessibility	PDO	Suitable mode
60C6h	00h	Min deceleration	command unit/s ²	0~4294967295	U32	rw	RxPDO	PP PV HM
Set the min deceleration. When set to 0, internal processing is processed as 1.								

Forward torque limit (60E0h)

Index	Sub index	Name	Unit	Range	Data type	Accessibility	PDO	Suitable mode
60E0h	00h	Positive torque limited	0.1%	0~65535	U16	rw	RxPDO	PP PV HM
Effective after version 3771								

Reverse torque limit (60E1h)

Index	Sub index	Name	Unit	Range	Data type	Accessibility	PDO	Suitable mode
60E1h	00h	Negative torque limited	0.1%	0~65535	U16	rw	RxPDO	PP PV HM
Effective after version 3771								

Position offset (60F4h)

Index	Sub index	Name	Unit	Range	Data type	Accessibility	PDO	Suitable mode
60F4h	00h	Position offset	command unit	-2147483648 ~2147483647	I32	RO	TxPDO	PP CSP HM

Internal command speed (60Fah)

Index	Sub index	Name	Unit	Range	Data type	Accessibility	PDO	Suitable mode
60FAh	00h	Internal command speed	command unit/s	-2147483648 ~2147483647	I32	RO	TxPDO	ALL

Internal command position (60FCh)

Index	Sub index	Name	Unit	Range	Data type	Accessibility	PDO	Suitable mode
60FCh	00h	Internal command position	command unit	-2147483648 - 2147483647	I32	RO	TxPDO	PP CSP HM

Digital input (60FDh)

Index	Sub index	Name	Unit	Range	Data type	Accessibility	PDO	Suitable mode
60FDh	00h	Digital inputs	-	0~4294967295	U32	ro	TxPDO	ALL

60FDh bit information (version before 3791):

bit	name	value	note
0	negative limit switch	0	No reverse overtravel switch signal detected
		1	Reverse overtravel switch signal detected
1	positive limit switch	0	No forward overtravel switch signal detected
		1	Forward overtravel switch signal detected
2	home switch	0	No origin switch signal detected
		1	Origin switch signal detected
3	EXT1 probe1	0	No input signal detected for probe 1
		1	Detected input signal from probe 1
4	EXT1 probe2	0	No input signal detected for probe 2
		1	Detected input signal from probe 2
5-31	Reserved	-	-

60FDh bit information (version 3791 and higher)

bit	name	value	note
0	negative limit switch	0	No reverse overtravel switch signal detected
		1	Reverse overtravel switch signal detected
1	positive limit switch	0	No forward overtravel switch signal detected
		1	Forward overtravel switch signal detected
2	home switch	0	No origin switch signal detected
		1	Origin switch signal detected
3	EXT1 probe1	0	No input signal detected for probe 1
		1	Detected input signal from probe 1
4	EXT1 probe2	0	No input signal detected for probe 2
		1	Detected input signal from probe 2
5	Z phase signal output	0	No Z-phase output signal detected
		1	Z-phase output signal detected
6-15	Reserved	-	-
16	Remote input SI1	0	Remote SI1 input signal not detected
		1	Remote SI1 input signal detected
17	Remote input SI2	0	Remote SI2 input signal not detected
		1	Remote SI2 input signal detected
18	Remote input SI3	0	Remote SI3 input signal not detected
		1	Remote SI3 input signal detected
19-31	Reserved	-	-

Digital output (60FEh)

Index	Sub index	Name	Unit	Range	Data type	Accessibility	PDO	Suitable mode
60FEh	-	Digital outputs	-	-	-	-	-	-
	01h	Output of operating the external output signal	-	-	-	-	-	-
	02h	Set output operation host machine function of external output signal	-	-	-	-	-	-

60FEh bit information (versions before 3791):

index	Bit	name	value	note
01h	0	Z-phase signal output status	0	The motor encoder has not passed zero and there is no Z-phase signal output.
			1	The motor encoder has passed zero, and the Z-phase

index	Bit	name	value	note
				signal outputs 1. The default signal holding output time is 2ms (set through P5-19), and then outputs 0.
02h	0	Z-phase signal output enable bit	0	Turn off Z-phase signal output.
			1	Turn on Z-phase signal output.

60FEh bit information (3791 and higher versions):

index	Bit	name	value	note
01h	0-15	Reserved	-	-
	16	Remote SO1 output status	0	Remote SO1 output signal not detected
			1	Remote SO1 output signal detected
	17	Remote SO2 output status	0	Remote SO2 output signal not detected
			1	Remote SO2 output signal detected
	18	Remote SO3 output status	0	Remote SO3 output signal not detected
1			Remote SO3 output signal detected	
02h	0-15	Reserved	-	-
	16	Remote SO1 output enable	0	Turn off remote SO1 output
			1	Turn on remote SO1 output
	17	Remote SO2 output enable	0	Turn off remote SO2 output
			1	Turn on remote SO2 output
	18	Remote SO3 output enable	0	Turn off remote SO3 output
1			Turn on remote SO3 output	

Target speed (60FFh)

Index	Sub index	Name	Unit	Range	Data type	Accessibility	PDO	Suitable mode
60FFh	00h	Target velocity	command unit/s	-4294967296~4294967295	U32	RW	RxPDO	PV

Supported drive mode (6502h)

This servo driver can confirm the supported control mode based on 6502h.

Index	Sub index	Name	Unit	Range	Data type	Accessibility	PDO	Suitable mode
6502h	00h	Supported drive modes	-	-2147483648~2147483647	I32	ro	TxPDO	ALL

6502h bit information:

bit	definition	abbr	correspond
0	Profile position mode	pp	YES
2	Profile velocity mode	pv	YES
3	Torque profile mode	tq	YES
5	Homing mode	hm	YES
7	Cyclic synchronous position mode	csp	YES
8	Cyclic synchronous velocity mode	csv	YES
9	Cyclic synchronous torque mode	cst	YES
10~31	-	-	-

Appendix 3. Glossary of Terms

Term/abbreviation	Full name
EtherCAT	Ethernet for Control Automation Technology
COE	CANopen Over EtherCAT
FMMU	Fieldbus Memory Management Unit
SM	Sync Manager
pp	Profile position
pv	Profile velocity
tq	Torque profile
csp	Cyclic synchronous position mode
hm	Homing mode
csv	Cyclic synchronous velocity mode
est	Cyclic synchronous torque mode
DC	Distributed Clock
SDO	Service Data Object
PDO	Process Data Object
TxPDO	-
RxPDO	-
ESM	EtherCAT State Machine
ESC	EtherCAT Slave Controller
PHY	Physical layer device that converts data from the Ethernet controller to electric or optical signals.
PDI	Process Data Interface or Physical Device Interface
EEPROM	Electrically Erasable Programmable Read Only Memory
ESI	EtherCAT Slave Information, stored in ESI EEPROM(formerly known as SII)

In TQ mode, modifying the slope type directly used for torque planning has no effect.

XINJE



We chat ID

WUXI XINJE ELECTRIC CO., LTD.

No.816, Jianzhu West Road, Binhu District, Wuxi City, Jiangsu Province, China
214072

Tel: (510) 85134136

Fax: (510) 85111290

Email: Fiona.xinje@vip.163.com

www.xinje.com